

## 8" MASONRY RETAINING WALL WITH A 4' MAXIMUM RETAINED HEIGHT

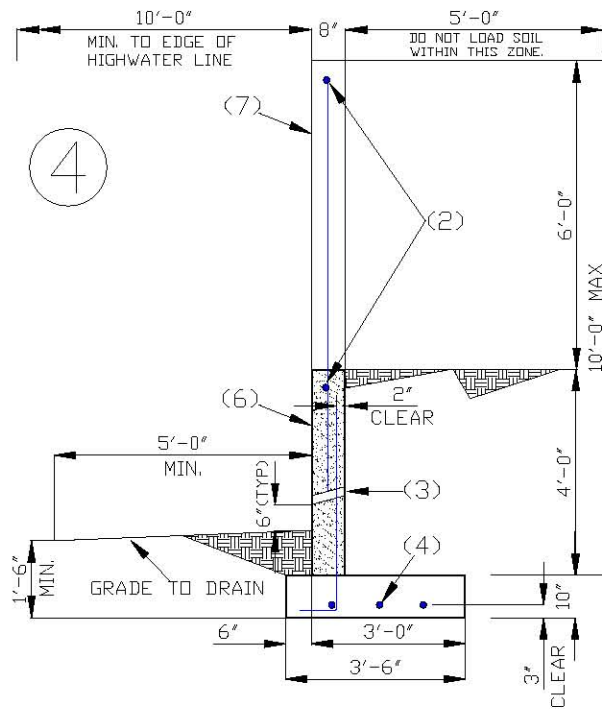
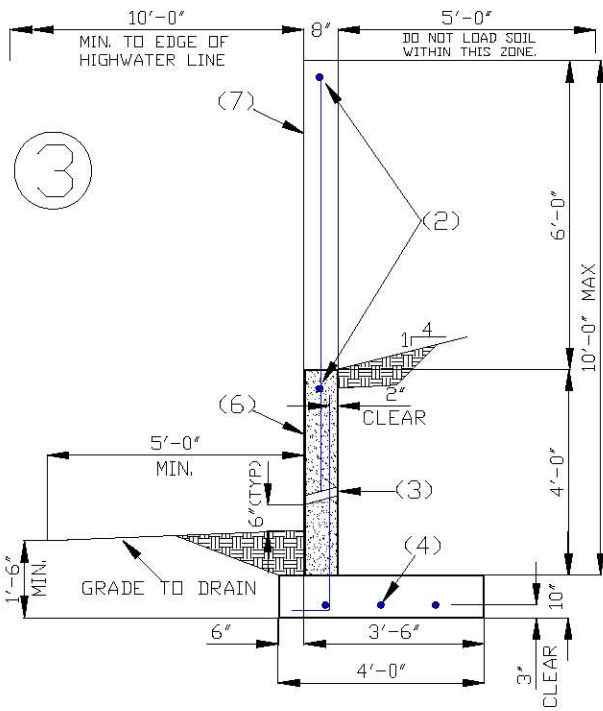
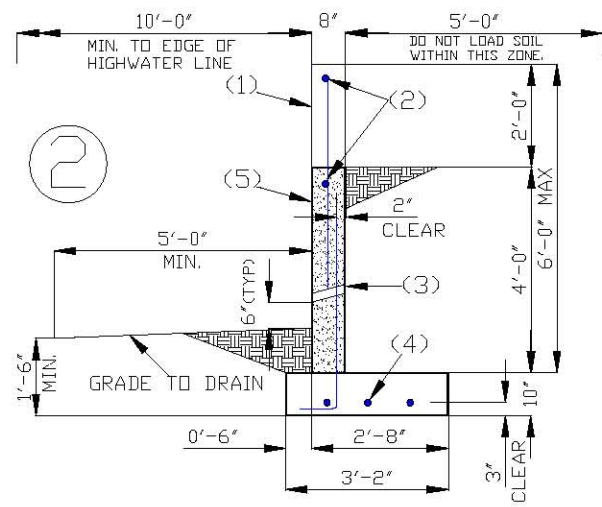
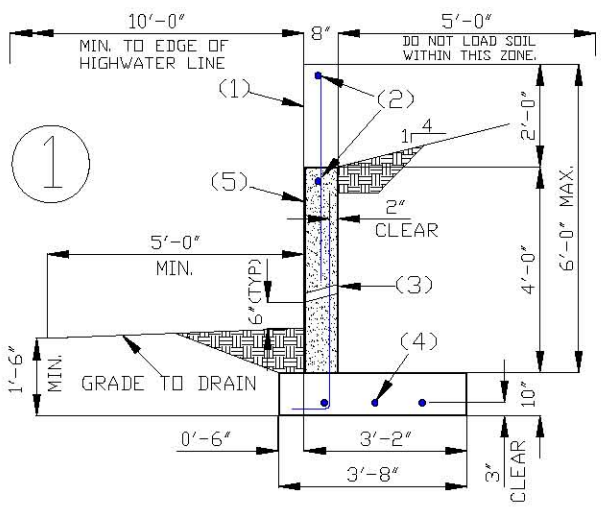

### NOTES:

- |  |   |
|--|---|
| (1) 8" CMU WITH #4 @ 40" O.C.  | (4) 3-#5 OR 4-#4 CONT. HORIZ. REBAR             |
| (2) 8" CONT. BOND BEAM WITH #4 CONT. HORIZ. REBAR                          | (5) 8" CMU WITH #4 @ 40" O.C.                   |
| (3) 2" DIAMETER WEEP HOLE @ 6'-0" O.C. WITH 12" CONT. GRAVEL POCKET BEHIND | (6) 8" CMU WITH #5 @ 32" O.C.                   |
|  | (7) 8" CMU WITH #4 @ 32" O.C. IN CENTER OF WALL |

### SPECIFICATIONS:

- |  |                                       |
|--|---------------------------------------|
| (1) MASONRY, MEDIUM Wt, ASTM C90, GRADE N, 1500psi | (4) REINFORCING: ASTM A-615, Fy=40ksi |
| (2) MORTAR, ASTM C270, TYPE S, 1800psi             | (5) CONCRETE: 2500psi                 |
| (3) GROUT, ASTM C476, 2000psi                      | (6) MIN. LAP 24"                      |

### \*SPECIAL NOTE\*

- THE CITY OF SCOTTSDALE MAKES NO REPRESENTATIONS AND ASSUMES NO RESPONSIBILITY OR LIABILITY IN PROVIDING THIS STANDARD DETAIL. OWNERS/APPLICANTS AND PROFESSIONALS USING THIS DETAIL SHALL ASSUME FULL RESPONSIBILITY FOR ITS DESIGN.
- OWNERS/APPLICANTS ARE ENCOURAGED TO CONSULT WITH A PROFESSIONAL ENGINEER OR ARCHITECT LICENSED BY THE STATE OF ARIZONA REGARDING THE NEEDS FOR THEIR PROJECT. AN ENGINEER OR ARCHITECT LICENSED BY THE STATE OF ARIZONA COULD DETERMINE DIFFERENT DETAILS OR SPECIFICATIONS.
- OWNER/APPLICANT/BUILDER IS RESPONSIBLE FOR VERIFYING SOIL; CONDITIONS AT THE FOOTING'S BEARING SURFACE AND IS SOLELY RESPONSIBLE FOR THE PERFORMANCE OF FOOTING.

Revised:  
04/08/2009