

2012

City of Scottsdale

**SUPPLEMENT TO
MAG UNIFORM STANDARD
DETAILS
for
PUBLIC WORKS CONSTRUCTION**



EFFECTIVE AUGUST 1, 2012

REVISED 6/20/12

2100 Series
General Information

2120	Survey Marker
2124	Accessible Signage
2131	Sign Post Installation
2132	Raised Pavement Marker Layout
2133-1*	Median Nose Signing – Type A & B
2133-2	Median Or Shoulder Signing
2134-1	Street Name Signs – Type A
2134-2	Street Name Signs – Type B
2134-3	Street Name Signs – 18” Metro
2134-4	Street Name Signs – 24” Metro
2134-5	Directional Street Name Sign
2135	Street Name Sign w/Stop Installation
2136	Advance Street Name Signs
2137	Loop Detectors
2138	Signal Pole Drilling Detail
2139	Traffic Signal Controller Cabinet Extender
2140	Model 330 Input Rack Wiring Instructions
2141	Tape Color Codes for Traffic Signal Wiring
2146-1	Refuse Enclosure
2146-2	Refuse Enclosure With Grease Containment Area
2147-1	Double Refuse Enclosure
2147-2	Double Refuse Enclosure With Grease Containment Area
2165-1	16’ Sliding Gate & Hinged Door
2165-2	16’ Sliding Gate

2200 Series
Street Information

2200	Pavement Replacement
2201	Trench Bedding & Backfill
2202	Trench Plating
2207	Residential Unpaved Road
2210	Grading Behind The Curb
2220	Curb And Gutter – Types "A" & "B"
2221	Curb And Gutter – Types "M" & "W"

2200 Series
Street Information (cont'd)

2225	Median Nose & Reverse Curve Details
2226	Median Nose Details
2228	Cut-Off Wall
2230	Sidewalk Cutout For Utility Poles
2231*	Detectable Warning Surface
2232*	Directional Sidewalk Ramps
2233-1*	Directional Sidewalk Ramps Retrofit – Type A
2233-2*	Directional Sidewalk Ramps Retrofit – Type B
2234*	Shared Curb Sidewalk Ramp
2235-1*	Mid-Block Sidewalk Ramp – Type A
2235-2*	Mid-Block Sidewalk Ramp – Type B
2237	Sidewalk Pavers (Non-Traffic Bearing)
2239*	Median Concrete Pavers
2240	6’ Valley Gutter & Apron
2250	Driveway Entrances
2255	Residential Driveways
2256	Commercial/Industrial Driveways–Type CL
2257	Commercial/Industrial Driveways–Type CH
2258	Commercial/Industrial Driveways–Type CI
2265-1*	Bus Shelter – Foundation Plan
2265-2	Bus Shelter – Framing Plan
2265-3	Bus Shelter – Sections
2265-4	Bus Shelter – Details
2265-5	Bus Shelter – Details
2265-6	Bus Shelter – Notes
2265-7	Bus Shelter – Abbreviations
2266-1	Closed End Bus Bay – Type "A"
2266-2	Closed End Bus Bay – Type "B"
2267	Far Side Bus Bay
2268	Base Slab And Foundations For Bus Stop Bench And Receptacles
2270	Frame & Cover Grade Adjustment
2282	Multi-Use Path Striping And Signing
2283	Multi-Use Path Details
2284	Multi-Use Path Wet Crossing Sign

2200 Series
Street Information (cont'd)

2285	Double Bicycle Rack
2290-1	Median Island Details
2290-2	Bulb Out/Choker Detail
2292-1*	Speed Table Details
2292-2	Speed Table Details
2293*	Mid-Block Pedestrian Table
2294	Intersection Pedestrian Table
2295	Pedestrian Refuge

2300 Series
Water Information

2305-1	Butterfly Valve Operator Manhole
2305-2	Butterfly Valve Operator Manhole
2315	Nonpotable Water Valve Box & Cover
2330	Water Service Line Connection
2332	Chlorine Injection Tap
2333	Tap For Future Chlorine Injection
2342-1	Pressure Reducing Valve
2342-2	Pressure Reducing Valve
2345-1	3”, 4”, 6” Water Meter
2345-2	3”, 4”, 6” Water Meter
2346	Temporary Construction Meter
2348	Air / Vacuum Release Valve
2349	Water Quality Sampling Station
2351	Double Check Valve Backflow Prevention Assembly For Assemblies 3” Thru 10”
2352*	Double Check Valve Backflow Prevention Assembly For Assemblies 3/4” Thru 2 1/2”
2353	Reduced Pressure Principle Backflow Prevention Assembly For Assemblies 3” Thru 10”
2354*	Reduced Pressure Principle Backflow Prevention Assembly For Assemblies 3/4” Thru 2 1/2”
2355*	Pressure Vacuum Breaker Assembly For Assemblies 1/2” Thru 2”

NOTE: * – New Or Revised Detail For 2012 Supplement

DETAIL NO.
2100-1

City of Scottsdale
Standard Details

APPROVED BY:
**Scottsdale Standards &
Specifications Committee**

INDEX

DETAIL NO.
2100-1

REVISED 6/20/12

2300 Series
Water Information (cont'd)

- 2356 Guard Posts For Backflow Prevention Assemblies
- 2357 Fill Pipe Details For Portable Tanks With Air Gap Separation
- 2358 Backflow Prevention Method For Portable Tanks With No Air Gap Separation
- 2359* "N" Shaped Double Check Valve Backflow Prevention Assembly For Assemblies 3" Thru 10"
- 2360* "N" Shaped Reduced Pressure Principle Backflow Prevention Assembly For Assemblies 3" Thru 10"
- 2361 Fire Hydrant Bypass Assembly
- 2362-1 1-1/2" - 2" Fire Line Connection
- 2362-2 3" And Larger Fire Line Connection
- 2363 Pavement Markers For Fire Hydrants
- 2364 Fire And Emergency Access And Delineation
- 2365 Fire Lane Sign
- 2366 Concrete Collar For Fire Hydrants
- 2367* Remote Fire Department Connection
- 2368* Fire Sprinkler Riser Detail With Remote FD Connection
- 2369* Fire Sprinkler Riser Detail With Wallmount FD Connection
- 2370* Vertical Realignment Of Water Mains
- 2372 Minimum Utility Separation Requirements
- 2374* Remote Fire Department Connection To Backflow Prevention Assembly
- 2380 Temporary Water Supply Hydrant Meter Assembly
- 2381 Temporary Blow-Off For Water Supply
- 2382 Temporary Water Service
- 2383 Water Line Flushing Assembly
- 2397 Electronic Ballmarker Placement
- 2398 Antenna Mast Detail
- 2399 Temporary Tap For Chlorine Injection

2400 Series
Sanitary Sewer Information

- 2401 Sanitary Sewer Separation / Protection From Water & Utility
- 2402 Force Main Discharge Manhole
- 2403 Two-Way Force Main Cleanout, 3" & Above
- 2404 Force Main Cleanout With Sewage Air Release Valve
- 2405 Sewer Air Release Valve
- 2420 Water Tight Concrete Sewer Manhole
- 2421 Sanitary Sewer Manhole Cover
- 2460 Monitoring/Sampling Vault

2500 Series
Storm Drain Information

- 2508* Handrail Detail
- 2515-1 Wall Opening & Erosion Protection - Type 1
- 2515-2 Drainage Grate At Block Wall
- 2515-3* Erosion Protection - Type 2
- 2520 Storm Drain Manhole Cover
- 2535 Catch Basin Grates
- 2554 Concrete Invert Paving For Corrugated Metal Pipe And Pipe Arch
- 2560-1 Storm Drain Inlet Marker
- 2560-2 Storm Drain Inlet Marker On Headwall
- 2560-3 Storm Drain Inlet Marker On Catch Basin/Scupper
- 2562-1 Storm Sewer Outfall Access Barrier
- 2562-2 Barrier Specifications Schedule

2600 Series
Landscaping, Irrigation & Trail Information

- 2600-1 Minimum Tree Size Requirements
- 2600-2 Minimum Tree Size Requirements
- 2620-1* Landscape Details
- 2620-2* Landscape Details
- 2620-3* Landscape Details
- 2620-4 Landscape Details
- 2622* Landscape Concrete Header
- 2631* Irrinet Pedestal Mounted Controller
- 2632* Scorpio Pedestal Mounted Controller
- 2633* Scorpio Wall Mounted Controller
- 2634* Irrinet Wall Mounted Controller
- 2635-1 Solar Controller
- 2635-2* Solar Controller And Backflow Preventer Enclosure
- 2636 Irrigation Push Button Control
- 2641-1* Single & Multi-Outlet Emitters
- 2641-2* Irrigation Emitter Layout
- 2642* Irrigation Trenching
- 2643 Irrigation Thrust Block
- 2644 Rotor Sprinkler Assembly
- 2645 Pop-Up Sprinkler Assembly
- 2646 Shrub Pop-Up Sprinkler Assembly
- 2647* Drip Filter & Pressure Regulator
- 2648* Emitter Flush Cap Assembly
- 2649 Quick Coupler Assembly
- 2650* 1-1/2" & Smaller Mainline Ball Valve
- 2651 2" & Larger Mainline Isolation Gate Valve
- 2653* 1-1/2" & Larger Master Valve/Flow Meter
- 2654* Remote Control Valve & Solar Controller Master Valve Assembly
- 2655 Typical Irrigation Wire Connection
- 2656 Irrigation Wire Sleeving Chart
- 2680-1 Trail Access Gates
- 2680-2 Trail Access Gates
- 2681 Trail Water Bars
- 2682 Trail Safety Barriers
- 2683* Trail Signs
- 2684 Trail Marker Sign

NOTE: * - New Or Revised Detail For 2012 Supplement

DETAIL NO.
2100-2

City of Scottsdale
Standard Details

APPROVED BY:
Scottsdale Standards & Specifications Committee

INDEX

DETAIL NO.
2100-2

NEW 3/31/10

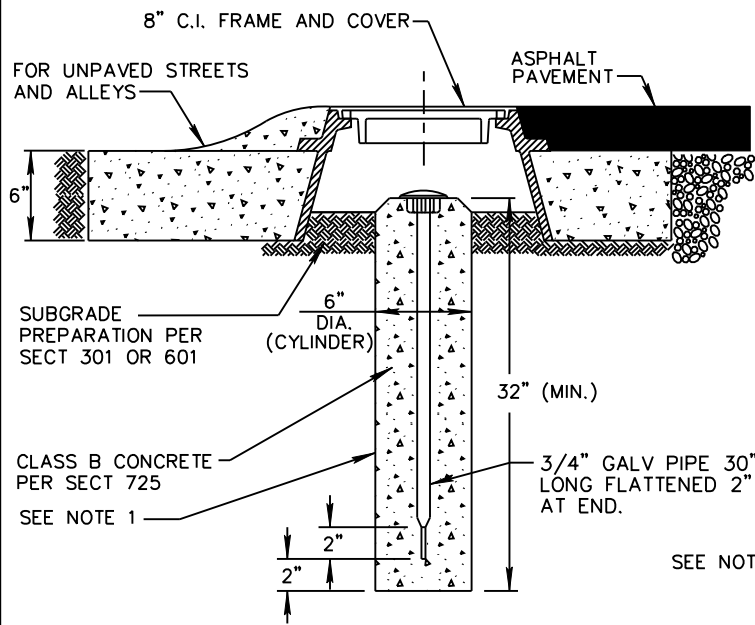

TYPE 'E'
(WITH FRAME)

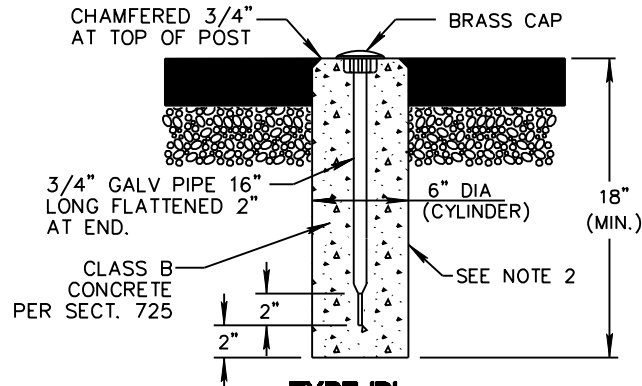

TYPE 'D'
(WITHOUT FRAME)

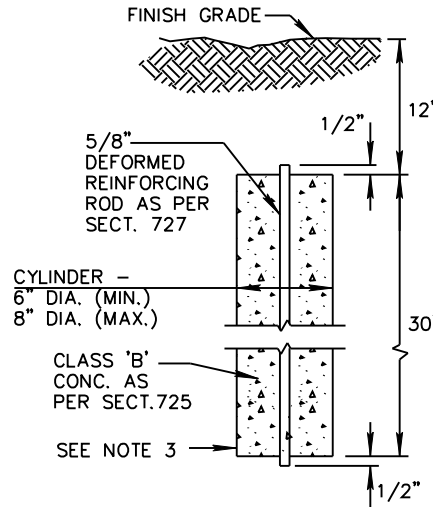

TYPE 'C'

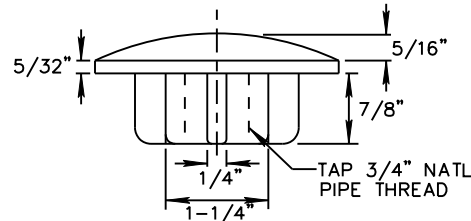
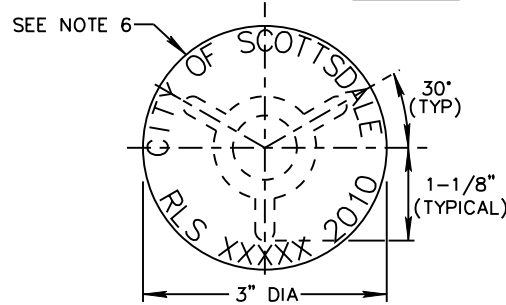

CAP DETAIL

NOTES:

1. TYPE "E" TO BE USED AT INTERSECTIONS OF MAJOR STREETS, COLLECTOR STREETS, SECTION AND QUARTER SECTION CORNERS PER ARS 33-103. CONCRETE POST IS CHAMFERED 3/4" AT TOP.
2. TYPE "D" TO BE USED AT 1/6TH CORNERS, INTERSECTIONS OF STREET CENTERLINES (EXCEPT WHERE TYPE "E" IS SPECIFIED), CORNERS OR CHANGES IN ALIGNMENT OF SUBDIVISION BOUNDARIES WITHIN THE ASPHALT SECTION, PC'S & PT'S OF ALL CURVES, AND PI'S WHEN WITHIN THE PAVED SECTION.
3. TYPE "C" TO BE USED AT CORNERS OF, AND CHANGE IN ALIGNMENT OF, SUBDIVISION BOUNDARIES WHERE CORNERS OR CHANGE POINTS FALL OUTSIDE OF PAVED AREAS OR IN ALLEYS.
4. WHEN MONUMENTS (BRASS CAP, HAND HOLE AND SECTION CORNERS, ETC.) DESCRIBED IN NOTES #1, #2 & #3 WILL BE DISTURBED DURING CONSTRUCTION, A "RESULTS OF SURVEY" WILL BE PREPARED BY A REGISTERED LAND SURVEYOR TO PRESERVE THE LOCATION. SEE MAG SECTION 405 FOR GUIDANCE. IN ALL CASES WHEN MONUMENTS ARE "SET", A RESULTS OF SURVEY SHALL BE RECORDED.
5. SECTION CORNERS, 1/4 CORNERS AND WHEN APPLICABLE, STAMP THE APPROPRIATE PUBLIC LAND MARKINGS PER CURRENT MANUAL OF INSTRUCTIONS FOR THE SURVEY OF THE PUBLIC LANDS OF THE UNITED STATES, PREPARED BY THE BUREAU OF LAND MANAGEMENT.
6. IN ALL CASES, THE POINT SURVEYED SHALL BE IDENTIFIED BY A PUNCH MARK AND IN ADDITION THE CAP SHALL BE STAMPED WITH THE REGISTERED LAND SURVEYOR (RLS) REGISTRATION NUMBER AND YEAR.
7. CAP TO BE CONSTRUCTED OF RED BRASS OR BRONZE. LETTERS TO BE 1/4" HIGH, APPROX. 1/32" WIDE, 1/32" DEEP AND 1/16" BORDER FROM EDGE OF CAP TO TOP OF LETTERING.
8. ALL COVERS INSTALLED, ADJUSTED OR REPLACED DURING CONSTRUCTION SHALL READ "SURVEY" PER MAG 270 AND ADJUSTED PER COS STANDARD DETAIL 2270.

DETAIL NO.
2120

**City of Scottsdale
Standard Details**

APPROVED BY:
**Scottsdale Standards &
Specifications Committee**

SURVEY MARKER

DETAIL NO.
2120

REVISED 4/24/07

NOTE:

Lettering shall be
Clearview 1-W font

- 2" Letters
- 6" Symbol
Royal Blue
Solid With
White Symbol
- 0.875" Letters
- 0.5" Letters



MOUNTING OPTIONS (SEE PLANS)

- A) Flexible P.E. Post With Surface Mount Base – Epoxy To Pavement Surface
- B) Perforated Galvanized Tubing Per COS Detail 2131. Install In Landscape Areas Only.
- C) Surface Mount To Structure
- D) Mount As Detailed On Plans

Green Borders and Text,
and Blue Symbol on White
Retroreflective Background (Typ.)
Background: ASTM Type IV Sheeting
Copy: Same As Above
Substrate: 0.080 Gauge
Treated Aluminum

ACCESSIBLE SIGNAGE

One Sign At Each
Accessible Parking Stall

Bottom of Sign Shall Be
Five Feet Above Finish Surface

REVISED 3/19/09

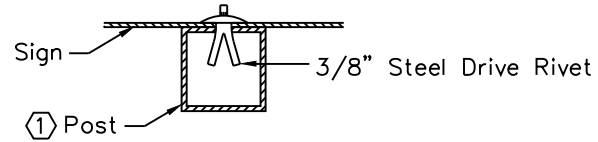
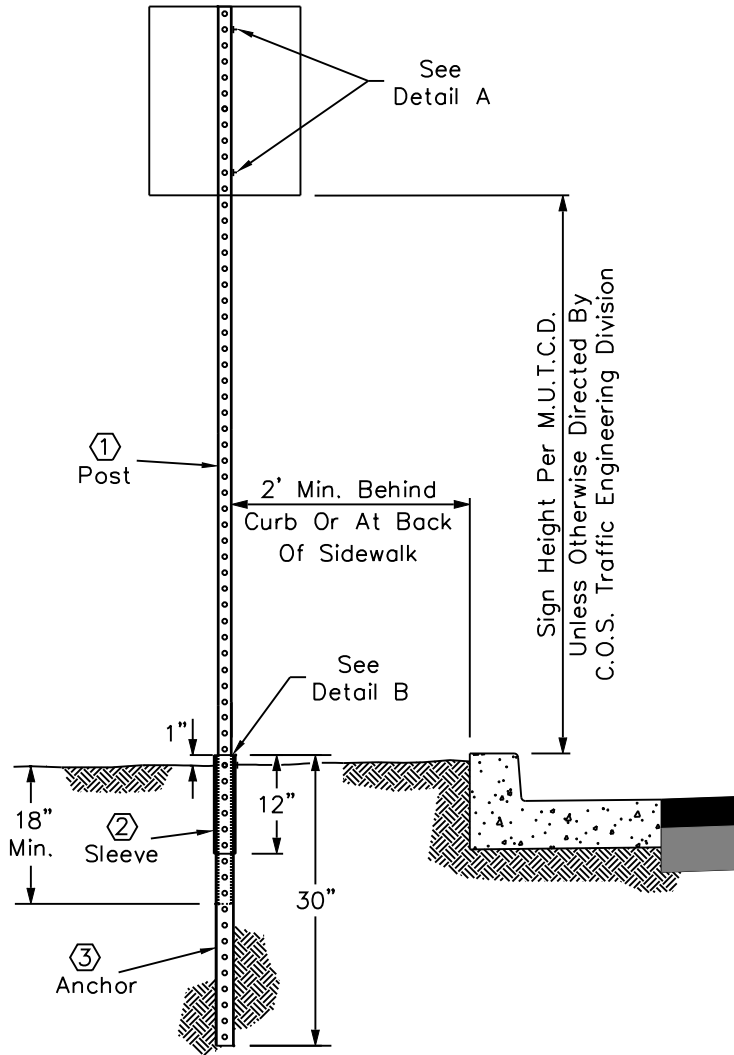

**Detail A
Sign Mounting**

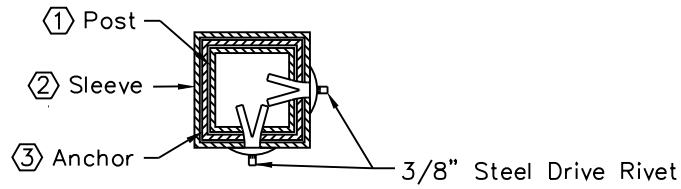

**Detail B
Anchor Assembly**

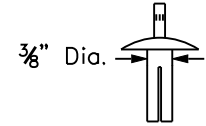

3/8" Steel Drive Rivet

Note: Aluminum rivets are not acceptable.

Legend

- ① Post - 1-3/4" x 1-3/4" Square Perforated 0.105" Galvanized Steel Tubing (Green Finish)
- ② Sleeve - 2-1/4" x 2-1/4" x 12", Square Perforated 0.105 Galvanized Steel Tubing
- ③ Anchor - 2" x 2" x 30", Square Perforated 0.105" Galvanized Steel Tubing

NOTE:

- 1. Sign Post, Sleeve And Anchor Shall Be As Per COS Specification Section 402.3

DETAIL NO.
2131

**City of Scottsdale
Standard Details**

APPROVED BY:
**Scottsdale Standards &
Specifications Committee**

SIGN POST INSTALLATION

DETAIL NO.
2131

REVISED 5/25/05

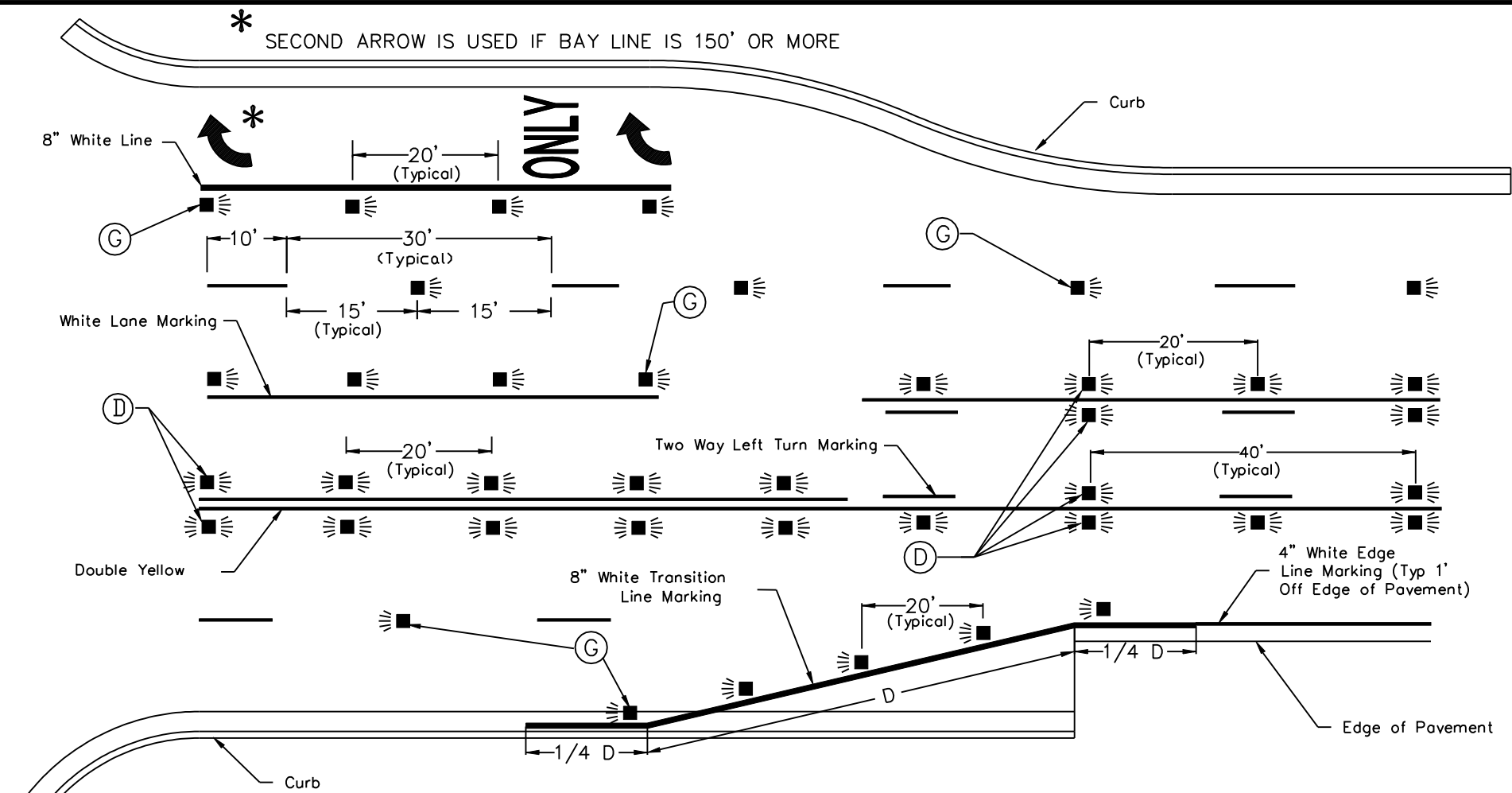

REFERENCE ADOT STD DRAWING M-19 FOR RAISED PAVEMENT MARKERS.

SEE STANDARD DETAIL 2363 FOR FIRE HYDRANT MARKERS

LEGEND

- ⓐ - TYPE "G" WHITE, ONE WAY REFLECTIVE
- ⓓ - TYPE "D" YELLOW, TWO WAY REFLECTIVE

DETAIL NO. **2132**
City of Scottsdale
Standard Details

APPROVED BY:
Scottsdale Standards & Specifications Committee

RAISED PAVEMENT MARKER LAYOUT

DETAIL NO. **2132**

REVISED 9/22/11

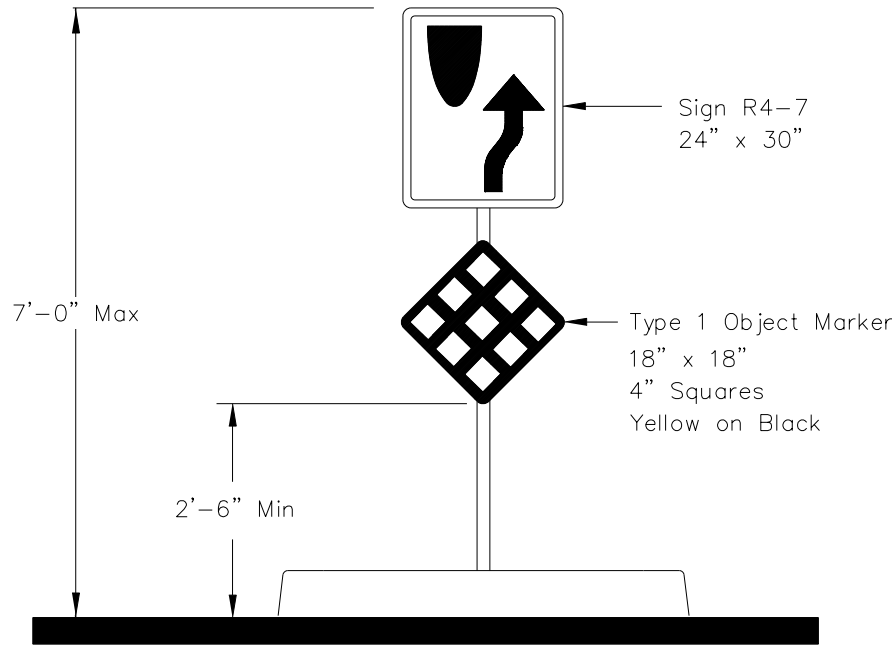

TYPE "A"

(AT SIGNALIZED INTERSECTIONS
OR AS SHOWN ON PLANS AND FIRST &
LAST NOSE ON A STRING OF MEDIANS)

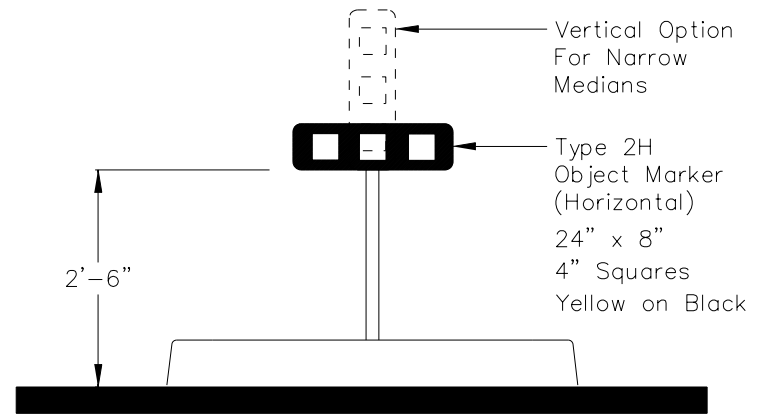

TYPE "B"

(ALL OTHER MEDIANS)

NOTES:

1. See COS Std Det 2225 Or 2226 For Typical Location.
2. Sign Posts Per COS Std Det 2131.

DETAIL NO.
2133-1

**City of Scottsdale
Standard Details**

APPROVED BY:
**Scottsdale Standards &
Specifications Committee**

MEDIAN NOSE SIGNING - TYPE A&B

DETAIL NO.
2133-1

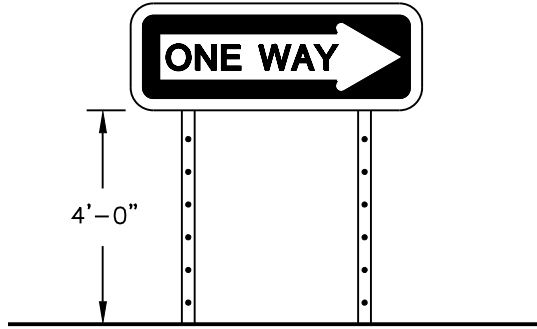

TYPE "A"

- R6-1R or R6-1L
- 12" x 36" blank size
- 0.125 blank type
- Black legend and background, white arrow

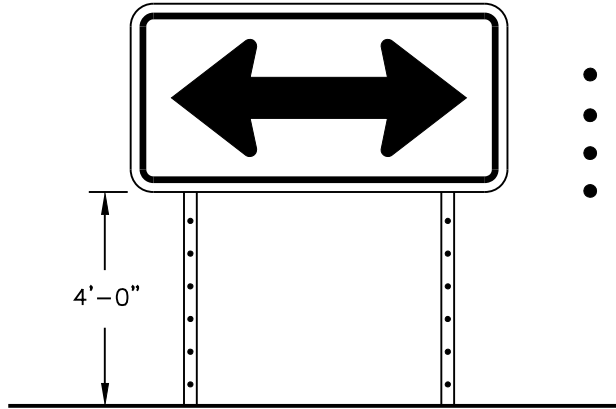

TYPE "B"

- W1-6R or W1-6L, or W1-7 (double arrow)
- 24" x 48" or 30" x 60" blank sizes
- 0.125 blank type
- Black arrow and border, yellow background

NOTES:

1. Sign posts per COS Std. Detail 2131
2. Sign sheeting per COS Supplemental Specs. Section 402.3.

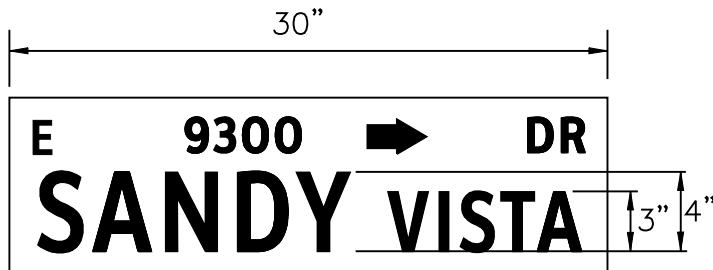
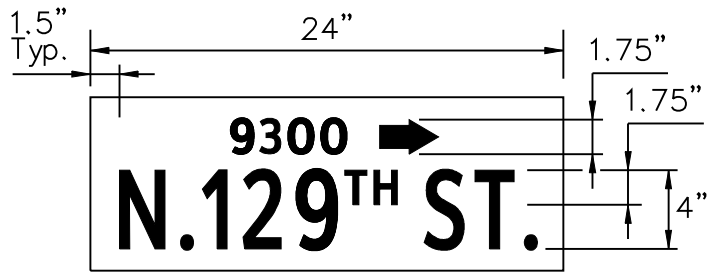

TYPE A SIGNS

ASTM Type IV Sheeting
Green/White (2 Sides)

Typeface: Clearview 2-W

Blank Sizes: 9"x 24", 9"x 30"
9"x 36", 9"x 42"

Blank Type: .091 extruded aluminum

Sign imaging: must meet FHWA standards and must be acrylic based electronic cuttable film (1170 series or equivalent) or silk screen ink. All inks and films shall be graffiti resistant.

Intended Usage: Type "A" Street Name Signs shall be used in residential areas where Residential Streets intersect with Local Collector Streets. See the COS General Plan for Street Designations.

Arrows on sign panels typically point north or east in the direction of increasing address number.

REVISED 5/06/08



TYPE B SIGNS

ASTM Type IV Reflective Sheeting
 Green/White (2 Sides)
 Typeface: Clearview 2-W
 Blank Sizes: 10"x 36", 10"x 42"
 Blank Type: 0.125 treated aluminum

Intended Usage: Type "B" Street Name Signs shall be used where a Residential Street or a Local Collector Street intersects with a street with a classification of Major Collector or larger. See the COS General Plan for Street Designations.

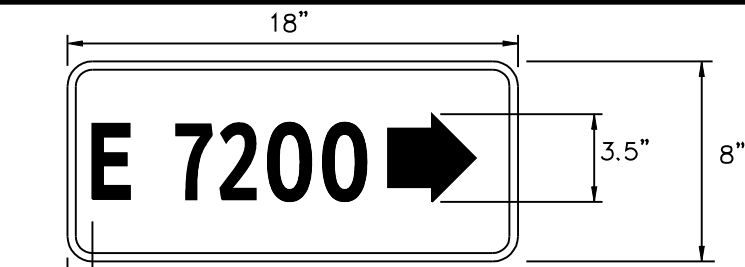

TYPE B BLOCK NUMBERS

ASTM Type IV Reflective Sheeting
 Green/White (2 Sides)
 Typeface: Clearview 2-W
 Blank Sizes: 8"x 18", 8"x 24"
 Blank Type: 0.125 treated aluminum

Type "B" Block Numbers to be mounted with Type "B" Street Name Signs. They shall be mechanically attached to the top of the Type B Street Name Sign using FHWA approved aluminum sign mounting brackets.

Sign imaging: Must meet FHWA standards. Must be acrylic based electronic cuttable film (1170 series or equivalent) or silk screen ink. All inks and films shall be graffiti resistant.

Arrows on sign panels typically point north or east in the direction of increasing address number.

DETAIL NO.
2134-2

City of Scottsdale
Standard Details

APPROVED BY:
Scottsdale Standards &
Specifications Committee

STREET NAME SIGNS - TYPE B

DETAIL NO.
2134-2

REVISED 5/08/08

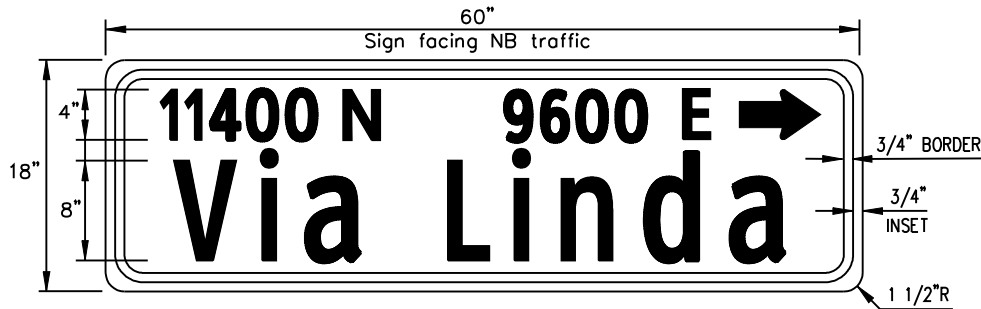

**SIGN FORMAT EXAMPLE
FOR OPPOSING TRAFFIC**



Sign facing
SB traffic

18" METRO SIGNS

Proposed ASTM Type XI Reflective Sheeting

Green/White (1 Side)

Typestyle: Clearview 2-W or 3-W

Blank Sizes: 18" x 48", 18" x 60", 18" x 72"

Blank Type: 0.080 Treated Aluminum

Intended Usage: 18" Metro Street Name Signs shall be used on signalized minor roads with a speed limit of 35MPH or lower. See the COS General Plan for Street Designations.

Arrows on sign panels typically point north or east in the direction of increasing address number.

DETAIL NO.
2134-3

**City of Scottsdale
Standard Details**

APPROVED BY:
**Scottsdale Standards &
Specifications Committee**

STREET NAME SIGNS - 18" METRO

DETAIL NO.
2134-3

REVISED 5/08/08

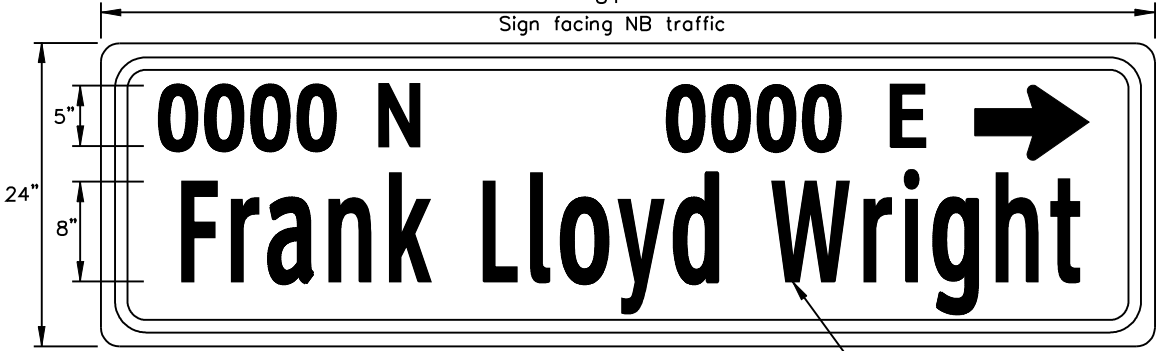
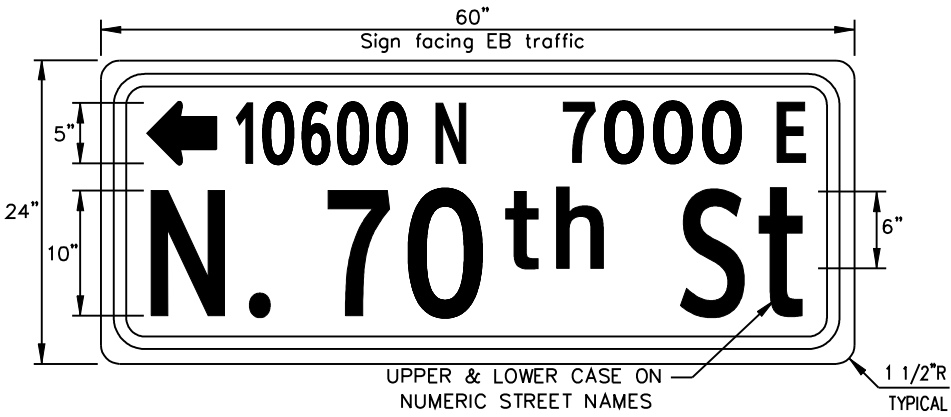

24" METRO SIGNS

Proposed ASTM Type XI Reflective Sheeting
 Green/White (1 Side)
 Typestyle: Clearview 2-W or 3-W
 Blank Sizes: 24" x 60", 24" x 72", 24" x 84"
 Blank Type: 0.125 Treated Aluminum

For street names that would exceed maximum length sign blank use 8" upper and lower case letters

Intended Usage: 24" Metro Street Name Signs shall be used on signalized major roads with a speed limit of 35MPH or higher. See the COS General Plan for Street Designations.
 Sign imaging: Must meet FHWA standards. Must be acrylic based electronic cuttable film (1170 series or equivalent) or silk screen ink. All inks and films shall be graffiti resistant.

SIGN FORMAT EXAMPLE FOR OPPOSING TRAFFIC



Sign facing WB traffic



Sign facing NB traffic



Sign facing SB traffic

Arrows on sign panels typically point north or east in the direction of increasing address number.

REVISED 5/08/08

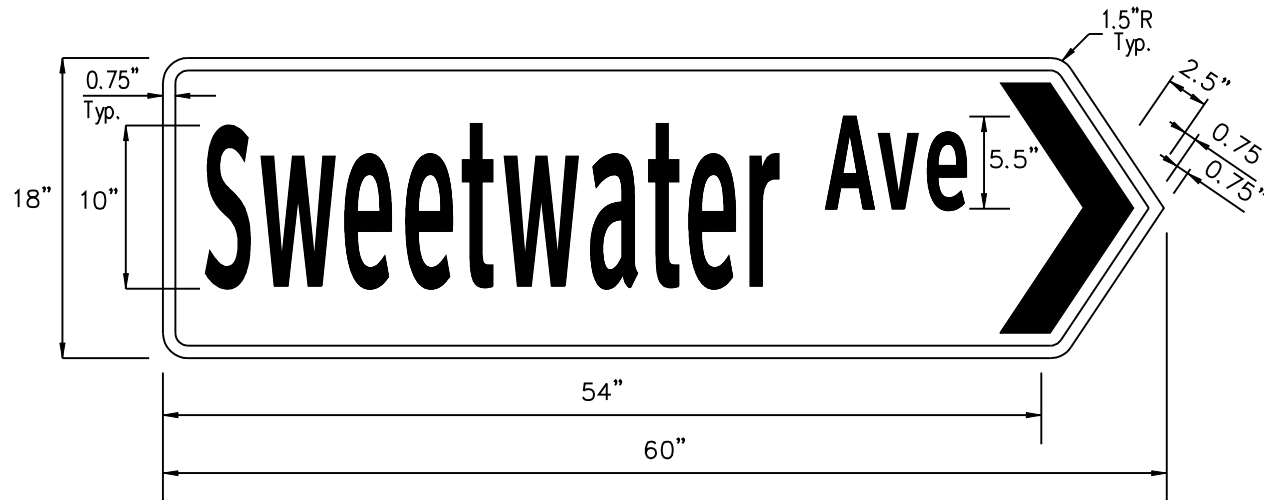

Blank Type: 0.100 gauge treated aluminum
Sheeting: ASTM Type IV – green background
Typestyle: Clearview 2–W upper and lower case
Legend and Border: White

DETAIL NO.
2134-5

City of Scottsdale
Standard Details

APPROVED BY:
Scottsdale Standards &
Specifications Committee

DIRECTIONAL STREET NAME SIGN

DETAIL NO.
2134-5

REVISED 5/08/08

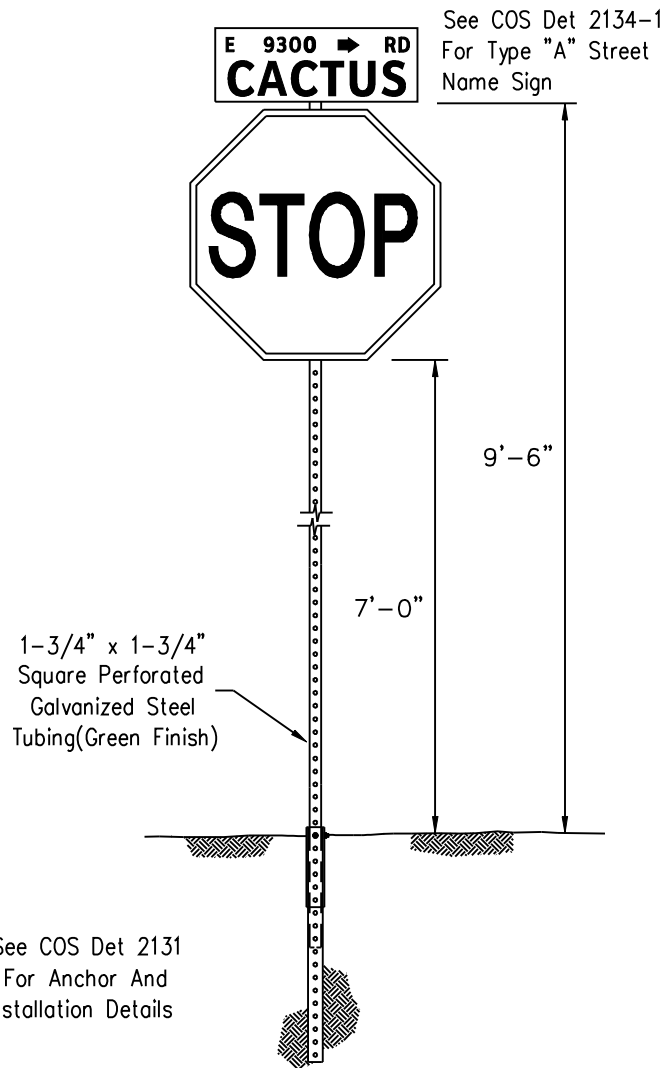

NOTES:

Street name sign and stop sign mounting height shall be measured from adjacent grade of sidewalk, top of curb or top of nearest pavement.

When no stop sign is required, the street name sign is mounted at 9 feet 6 inches.

When two street name signs are mounted one on top of the other, the height is measured to the bottom sign.

DETAIL NO.
2135

**City of Scottsdale
Standard Details**

APPROVED BY:
**Scottsdale Standards &
Specifications Committee**

STREET NAME SIGN WITH STOP SIGN INSTALLATION

DETAIL NO.
2135

REVISED 5/12/08

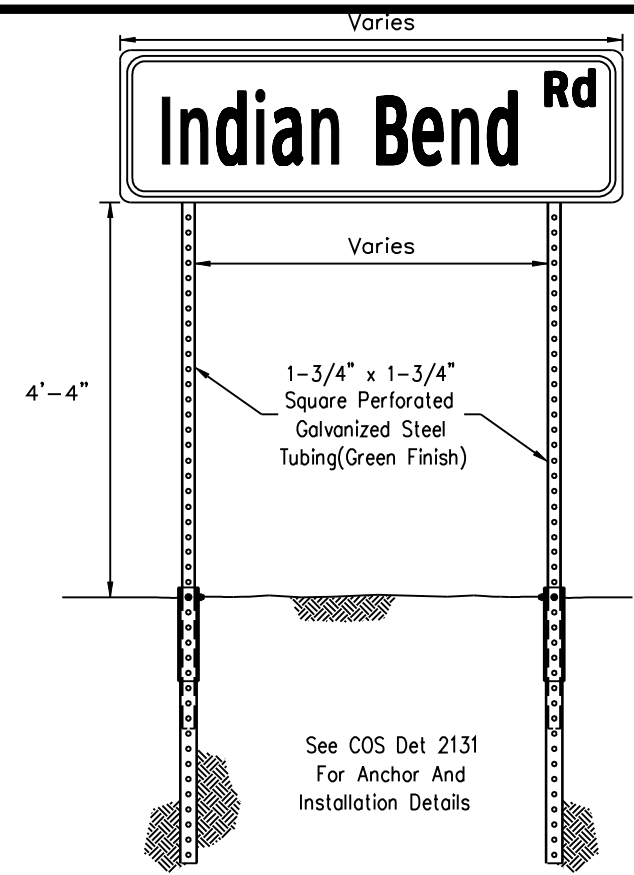
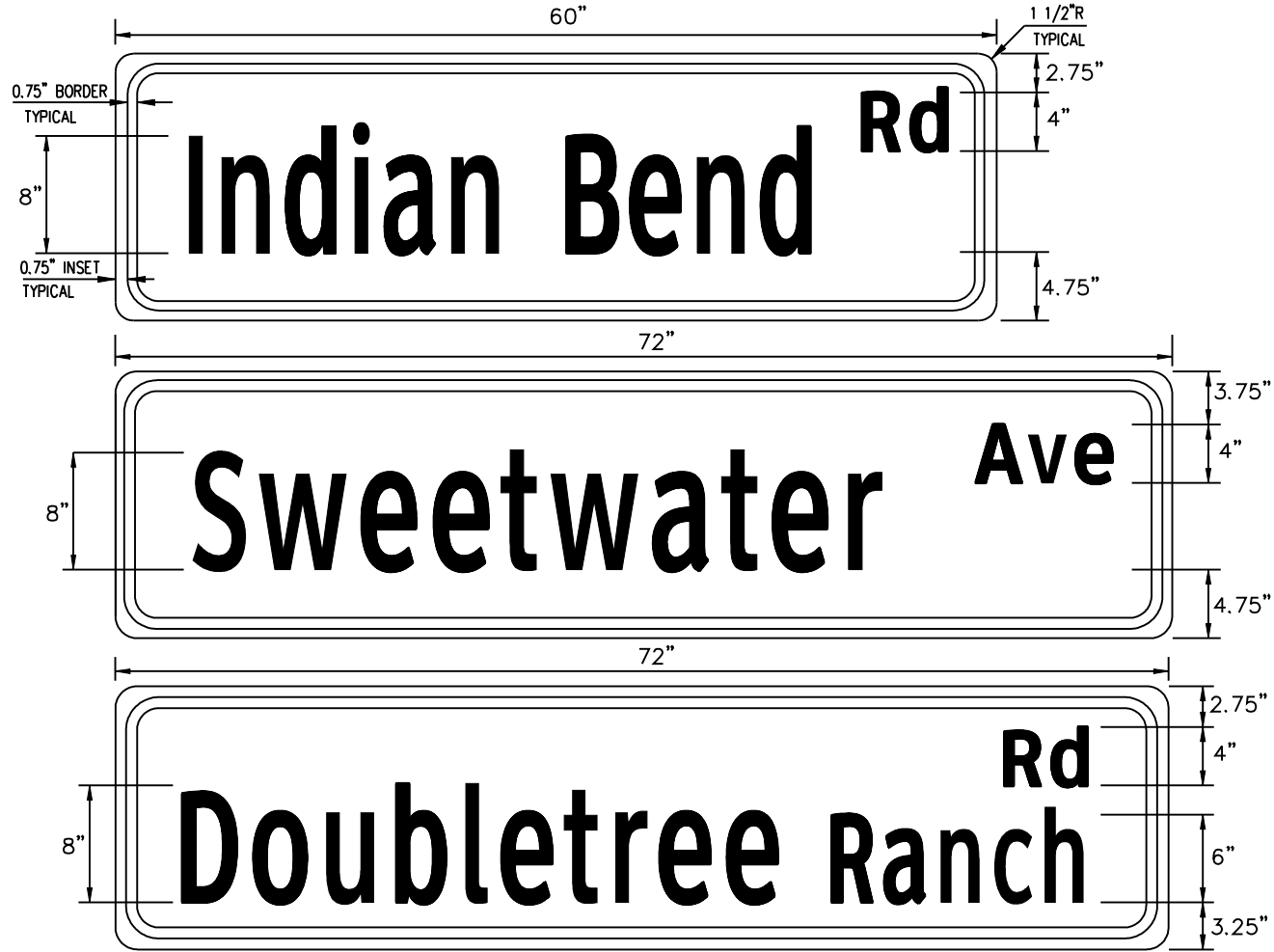

Proposed ASTM Type XI (1 Side) Blank Sizes: 18" x 48", 18" x 60", 18" x 72"
 Typestyle: Clearview 2-W or 3-W Blank Type: 0.080 Treated Aluminum
 Sign imaging: Must meet FHWA standards and must be acrylic based electronic cutting film
 (1170 series or equivalent) or silk screen ink. All inks and films shall be graffiti resistant.

Intended Usage: In advance of the specified street where a collector street intersects a minor/major arterial or expressway. Location determined by multiplying the posted speed limit by 10. Sign is typically placed in a center median when available, otherwise on the right hand side of the road.

DETAIL NO. 2136	City of Scottsdale Standard Details	APPROVED BY: Scottsdale Standards & Specifications Committee	ADVANCE STREET NAME SIGNS	DETAIL NO. 2136
---------------------------	---	--	----------------------------------	---------------------------

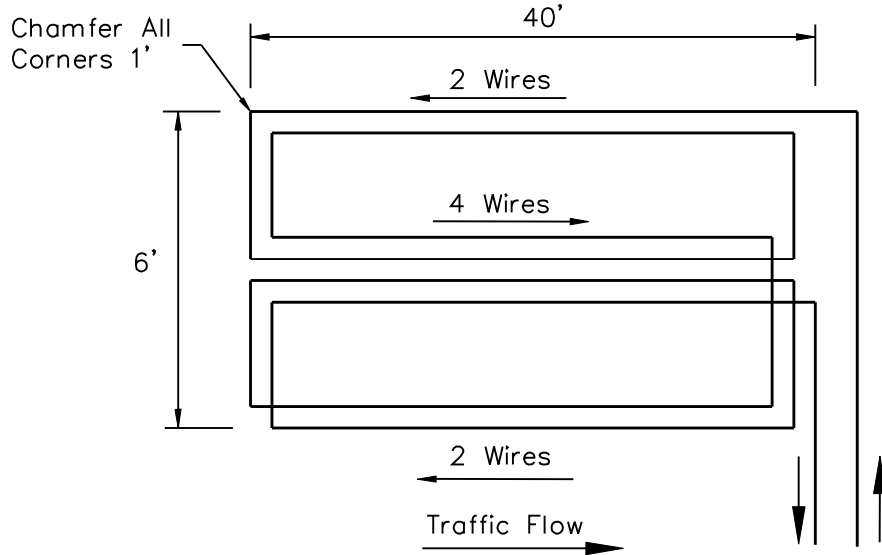

**QUADRUPOLE LOOP DETECTOR
For Left Turn Lanes Only**

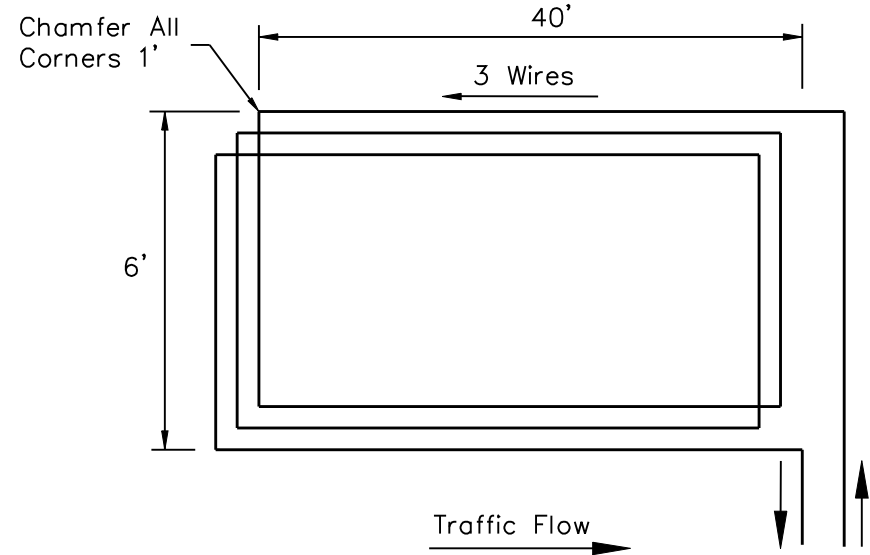

STANDARD LOOP DETECTOR

NOTES:

1. All loop detectors shall be wire-in-duct type wire. (Detect-a-Duct or approved equivalent, #14 stranded inside a 1/4" PVC tubing (IMSA 51-5).
2. All loop detectors shall be centered in the middle of the applicable traffic lane. Loop shall be sufficiently dimensioned on the plans. Loop detectors shall extend five feet into the crosswalk unless directed otherwise by the Traffic Engineering Department.
3. A rectangular loop with 3 turns (6 feet x 40 feet) shall be used for all through lanes.
4. A quadrupole loop with 2 outside turns and 4 inside turns (6 feet x 40 feet) shall be used in all exclusive left-turn lanes. (Wire in middle cut shall run the same direction).
5. Loop detectors shall not be installed in exclusive right turn lanes.
6. The location of permanent count detector loops shall be specified by the Traffic Engineering Department. Count detector loops shall consist of a minimum of 4 turns (6 feet x 6 feet).

7. Pre-formed loop detectors conforming to the latest ADOT specifications shall be used under decorative pavement, "pavers", concrete, or other "special" roadway surfaces, or as directed by the Traffic Engineering Department.
8. Lead-in cable between loop wire and controller shall be latest ADOT specification or approved equivalent (IMSA 50-2).
9. Loop lead-in and splices in pull box shall be twisted and soldered. Griggs Loop Detector Sealant, 3-M Loop Sealant, or approved equivalent shall be used.
10. Loops shall be installed prior to the installation of the final pavement lift (if part of a paving project).
11. Loops shall be inspected and tested prior to acceptance by the City.
12. See ADOT TS 7-1 for installation details.

DETAIL NO.
2137

**City of Scottsdale
Standard Details**

APPROVED BY:
**Scottsdale Standards &
Specifications Committee**

LOOP DETECTORS

DETAIL NO.
2137

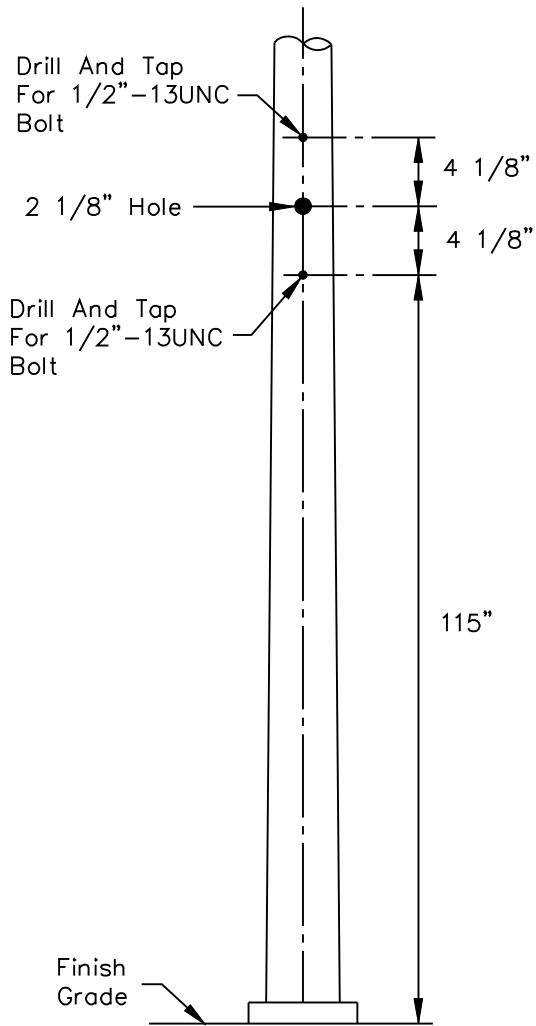

SIDE MOUNT DRILLING DETAIL

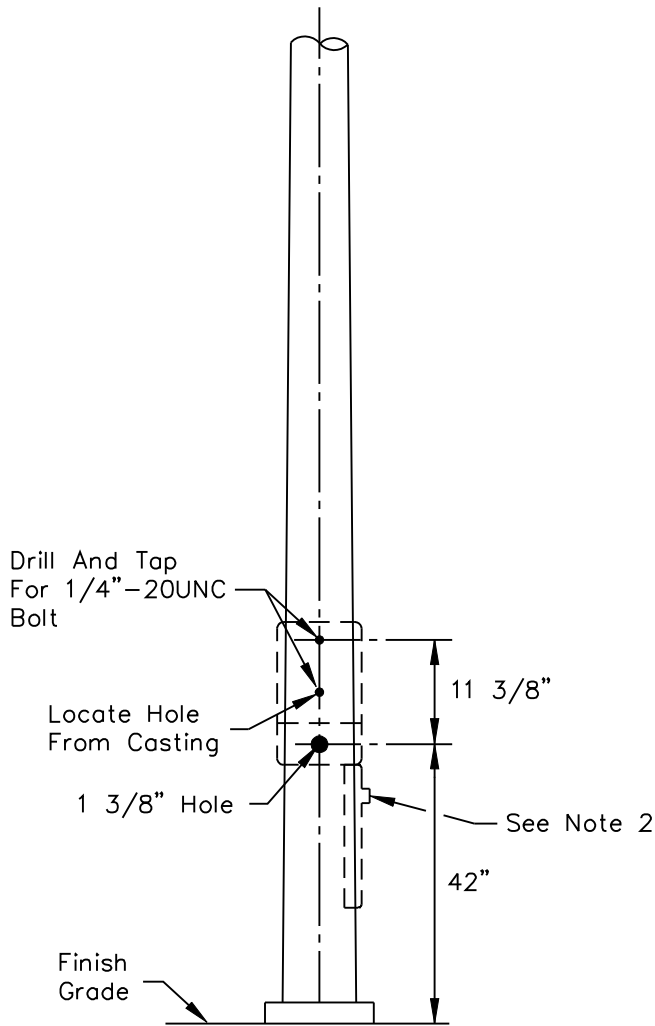

PUSH BUTTON DRILLING DETAIL

NOTES:

1. Drilling of pole to be oriented according to pole layout, or as directed by C.O.S. Engineer in the field.
2. When two pedestrian push button assemblies are mounted on a small diameter pole the lower assembly shall be positioned upside down so that the push button is at the top and the sign is below.
3. Top mounting holes to be field drilled in order to allow for manufacturing variations.
4. Push button shall be A.D.A large target style (ADOT Type I).

DETAIL NO.
2138

**City of Scottsdale
Standard Details**

APPROVED BY:
**Scottsdale Standards &
Specifications Committee**

SIGNAL POLE DRILLING DETAIL

DETAIL NO.
2138

REVISED 4/24/07

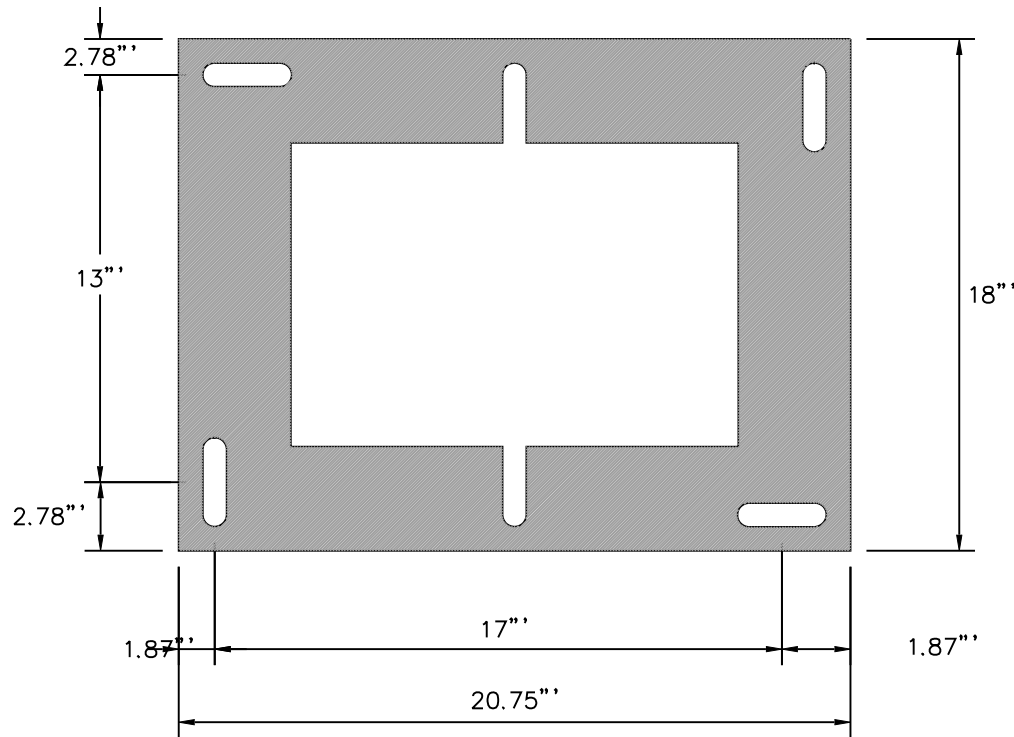

**INSIDE VIEW OF BOTH
SIDES OF BASE EXTENDER**

Notes:

1. Model 330 cabinet base extenders will include cutouts that will accommodate replacement with all other Scottsdale 330 cabinets and model 336S. These base extenders are available from the cabinet manufacturer. All Scottsdale cabinets are foundation mounted.
2. Foundation must include a 4"x30"x30" concrete pad in front of the cabinet door.
3. The cabinet shall be mounted in such a way that when the technician has the door open and is facing the cabinet, he is also facing the intersection.
4. Cabinet base extender shall have a 12" x 12" removable access panel. Base extender shall be installed so that access panel is on door side of cabinet.

DETAIL NO.
2139

**City of Scottsdale
Standard Details**

APPROVED BY:
**Scottsdale Standards &
Specifications Committee**

**TRAFFIC SIGNAL CONTROLLER CABINET
BASE EXTENDER**

DETAIL NO.
2139

LOOP AND PEDESTRIAN PUSH BUTTON INPUTS

Slot 1	Slot 2	Slot 3	Slot 4	Slot 5	Slot 6	Slot 7	Slot 8	Slot 9	Slot 10	Slot 11	Slot 12	Slot 13	Slot 14
1 AB Ph 1	3 AB Ph 2	5 AB Ph 3	7 AB Ph 4	9 AB Ph 5	11 AB Ph 6	13 AB Ph 7	15 AB Ph 8	17 AB 1 PPB	19 AB 3 PPB	21 AB RRPre	23 AB AdvEn	25 AB EV A	27 AB Stop Time
2 AB Ph 1	4 AB Ph 2	6 AB Ph 3	8 AB Ph 4	10 AB Ph 5	12 AB Ph 6	14 AB Ph 7	16 AB Ph 8	18 AB 5 PPB	20 AB 7 PPB	22AB Flash	24 AB Adv	26 AB EV B	28 AB 6 Call
Det Loops	Det Loops	Det Loops	Det Loops	Det Loops	Det Loops	Det Loops	Det Loops	Ped Push Buttons	Ped Push Buttons	-----	-----	Pre- Empt	Slot 14 ----- Slot 14

1. All Scottsdale model 330 cabinet input racks have 14 slots.
2. Slots 1–8 are for vehicle detector loops.
3. Phase 4 loops are terminated on slot 4 (7A&B and/or 8A&B).
4. Phase 4 pedestrian push button is terminated on 19A and ppb neutral on 19B.
5. 19B shall have a jumper to the neutral bar.
6. All two phase intersections are to be wired to phases 2 and 4.
7. Field output wiring for 2 phase signals shall be wired to 2R, 2Y, 2G and 4R, 4Y, 4G.
8. Ped field wiring shall be wired to 9R, 9G (Phase 2 Ped) and 10R, 10G (Phase 4 Ped).
9. Call COS Traffic Signals (480)312–5635 prior to wiring cabinet for instructions for intersections with more than 2 phases.

REVISED 4/24/07

 DETAIL NO.
2140
**City of Scottsdale
Standard Details**

 APPROVED BY:
**Scottsdale Standards &
Specifications Committee**
MODEL 330 INPUT RACK WIRING INSTRUCTIONS

 DETAIL NO.
2140

MAIN DIRECTIONS

Direction	Color
WB	Blue
EB	Green
NB	Red
SB	Yellow

**LEFT TURN DIRECTIONS
(Main Color + White)**

Direction	Color
WBLT	Blue + White
EBLT	Green + White
NBLT	Red + White
SBLT	Yellow + White

**RIGHT TURN DIRECTIONS
(Main Color + Black)**

Direction	Color
WBRT	Blue + Black
EBRT	Green + Black
NBRT	Red + Black
SBRT	Yellow + Black

**Color Of Wire For
Power/Neutrals/Pushbuttons**

Wire	Color
AC+ Power	Black
AC- (Neutral)	White
24V Pushbutton	Orange, Stranded

WBLT = West Bound Left Turn and shall be the phase for vehicles facing west and turning to south

EBLT = East Bound Left Turn and shall be the phase for vehicles facing east and turning to north

NBLT = North Bound Left Turn and shall be the phase for vehicles facing north and turning to west

SBLT = South Bound Left Turn and shall be the phase for vehicles facing south and turning to east

WBRT = West Bound Right Turn and shall be the phase for vehicles facing west and turning to north

EBRT = East Bound Right Turn and shall be the phase for vehicles facing east and turning to south

NBRT = North Bound Right Turn and shall be the phase for vehicles facing north and turning to east

SBRT = South Bound Right Turn and shall be the phase for vehicles facing south and turning to west

DETAIL NO.
2141

**City of Scottsdale
Standard Details**

APPROVED BY:
**Scottsdale Standards &
Specifications Committee**

TAPE COLOR CODES FOR TRAFFIC SIGNAL WIRING

DETAIL NO.
2141

NOTE:

1. 1/2" Expansion Joint, ASTM D-1751 Per MAG Section 729.

30' x 14' x 6" Thick Concrete Approach Slab With Thickened Edges, Class "B" Concrete w/ 6"x 6", 1.4 x 1.4 WWF, On Compacted Subgrade. Approach Slab Shall Have A Constant Slope Which Matches The Enclosure Slab.

30' x 14' x 6" Thick Concrete Approach Slab With Thickened Edges, Class "B" Concrete w/ 6"x 6", 1.4 x 1.4 WWF, On Compacted Subgrade. Approach Slab Shall Have A Constant Slope Which Matches The Enclosure Slab.

* In locations where a 30' approach slab is not possible, approval from the City of Scottsdale Quality Compliance Division is required.

8" CMU Or Block Or Stucco To Match Building

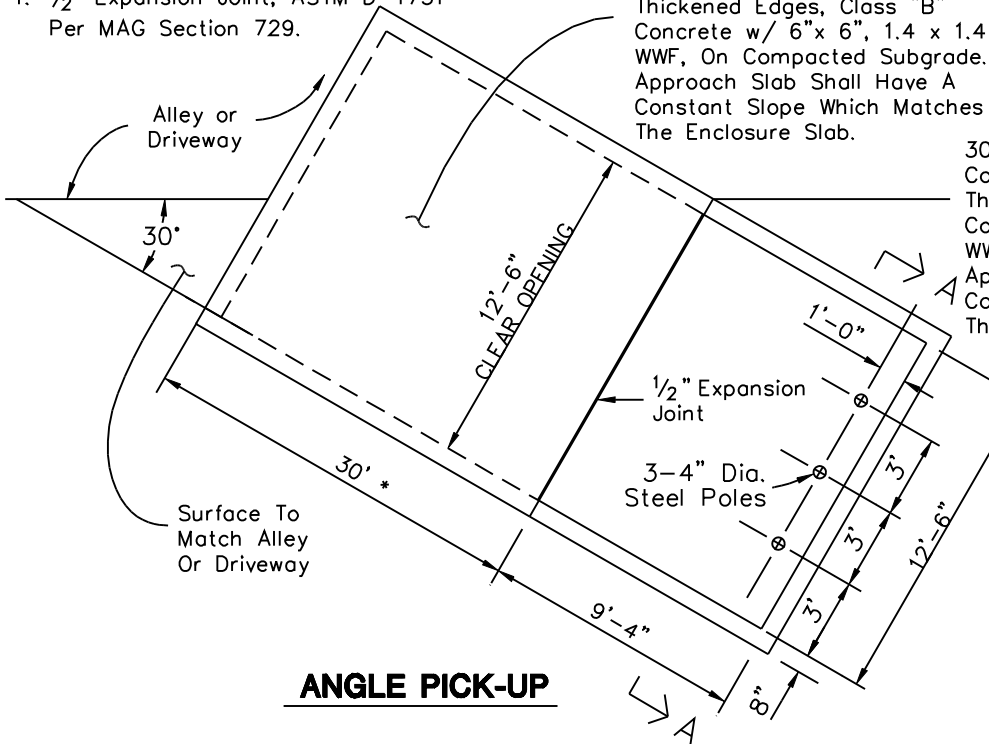

ANGLE PICK-UP

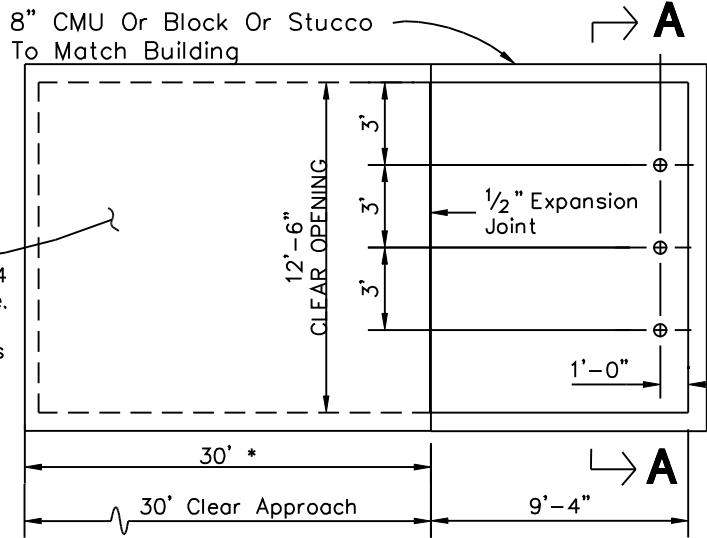

HEAD ON PICK-UP

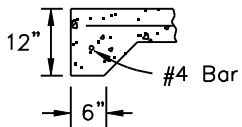

APPROACH SLAB THICKENED EDGE DETAIL

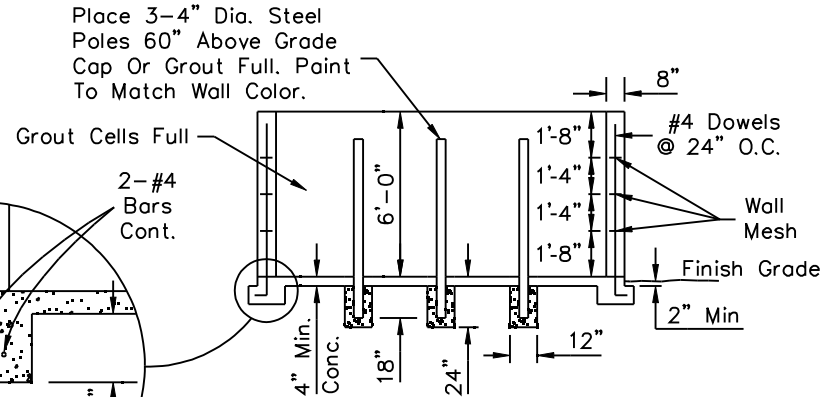
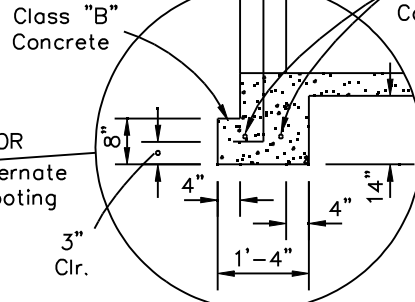
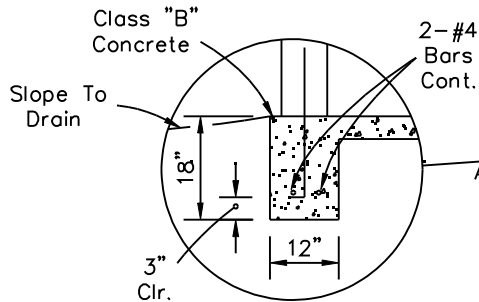

SECTION A-A

DETAIL NO.
2146-1

**City of Scottsdale
Standard Details**

APPROVED BY:
**Scottsdale Standards &
Specifications Committee**

REFUSE ENCLOSURE

DETAIL NO.
2146-1

REVISED 5/9/02

REVISED 5/9/02

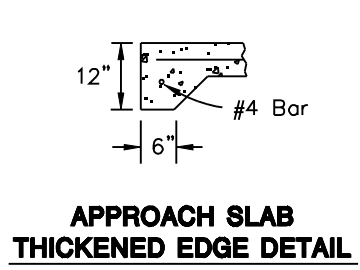
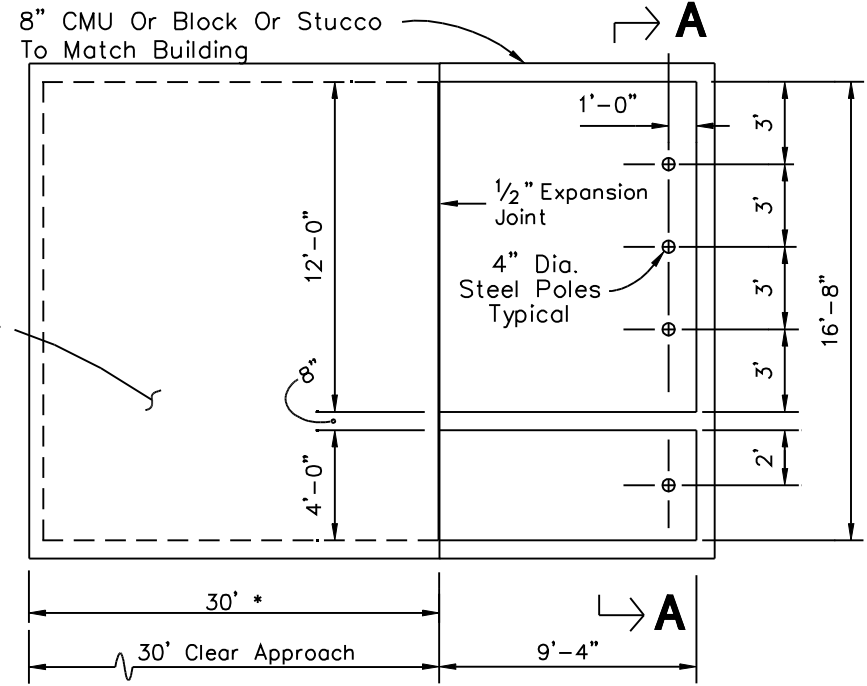
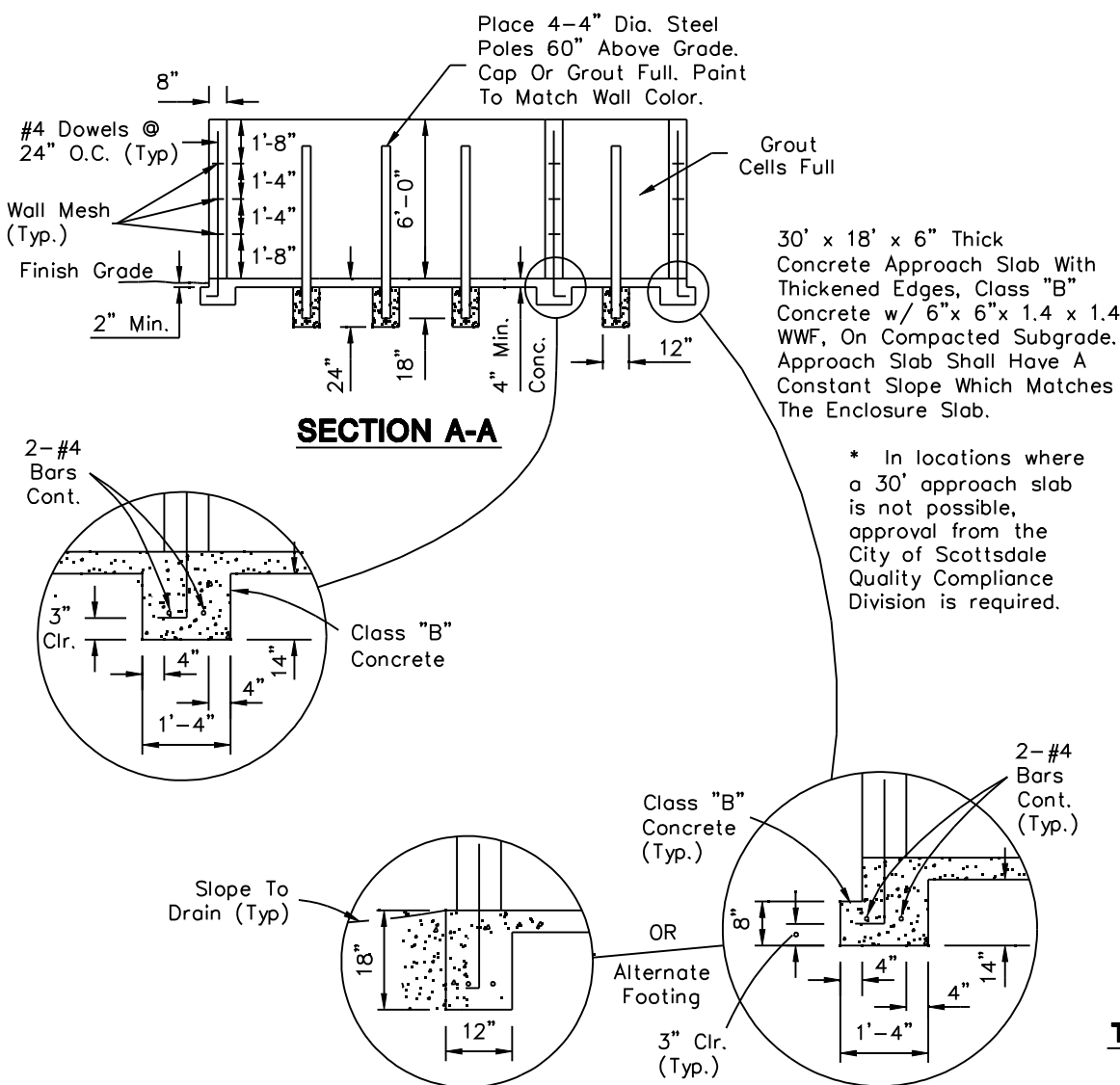

- NOTES:**
1. Enclosure For Angle Pick-up Similar To COS Detail 2146-1
 2. 1/2" Expansion Joint, ASTM D-1751 Per MAG Section 729.

REVISED 5/9/02

Place 6-4" Dia. Steel Poles 60" Above Grade Cap Or Grout Full. Paint To Match Wall Color.

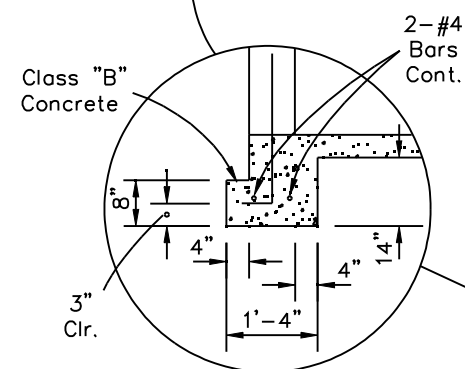
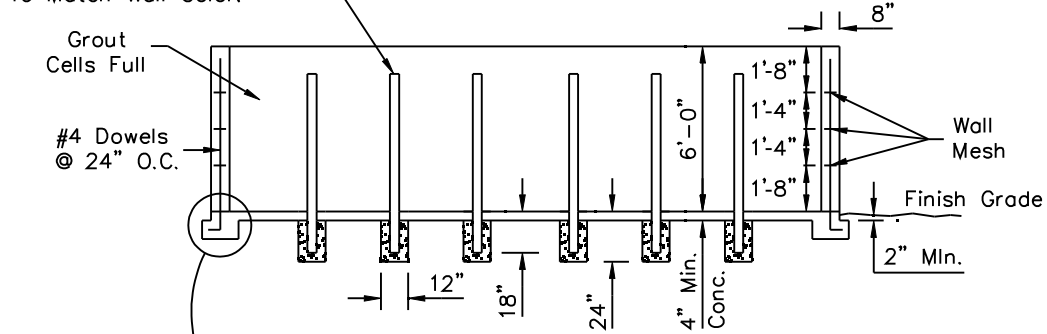

SECTION A-A

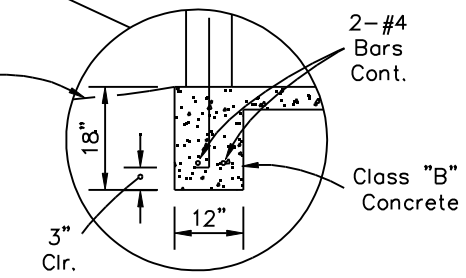
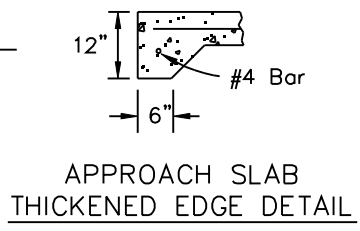

OR Alternate Footing

30' x 23' x 6" Thick Concrete Approach Slab With Thickened Edges, Class "B" Conc. w/ 6"x 6", 1.4 x 1.4 WWF, On Compacted Subgrade. Approach Slab Shall Have A Constant Slope Which Matches The Enclosure Slab.

* In locations where a 30' approach slab is not possible, approval from the City of Scottsdale Quality Compliance Division is required.

8" CMU Or Block Or Stucco To Match Building

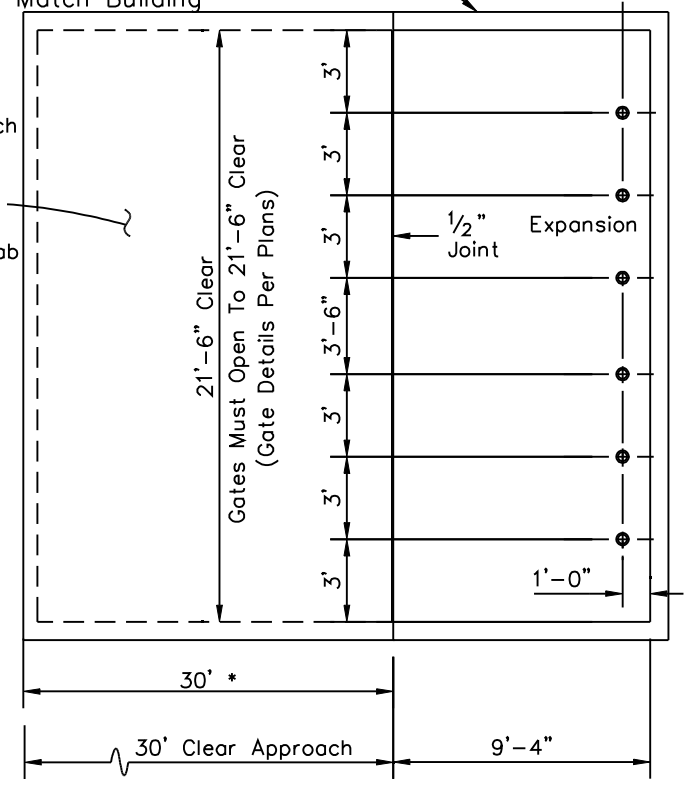

PLAN

NOTE:

1. Double Enclosure For Angle Pick-Up Similar To COS Det. 2146-1
2. 1/2" Expansion Joint, ASTM D-1751 Per MAG Section 729.

DETAIL NO. **2147-1** City of Scottsdale Standard Details

APPROVED BY: **Scottsdale Standards & Specifications Committee**

DOUBLE REFUSE ENCLOSURE

DETAIL NO. **2147-1**

REVISED 5/9/02

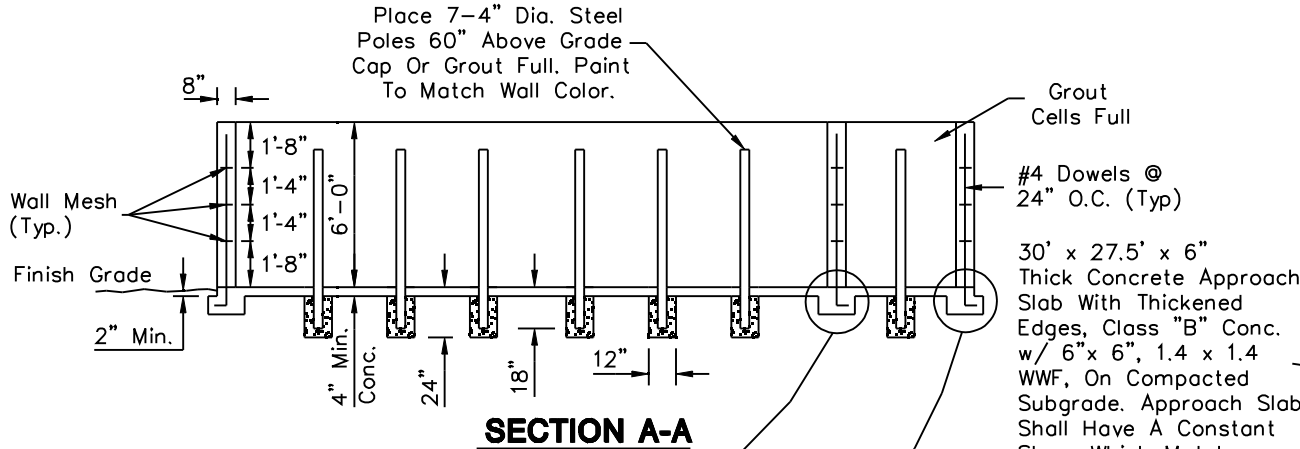

SECTION A-A

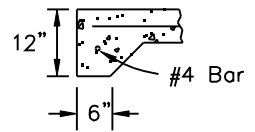
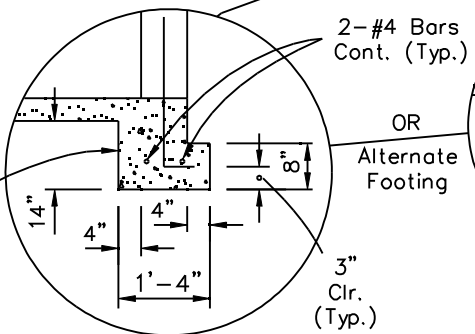
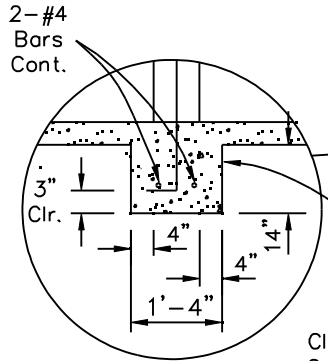

APPROACH SLAB THICKENED EDGE DETAIL

NOTES:

1. Double Enclosure For Angle Pick-Up Similar To COS Det. 2146-1
2. 1/2" Expansion Joint, ASTM D-1751 Per MAG Section 729.

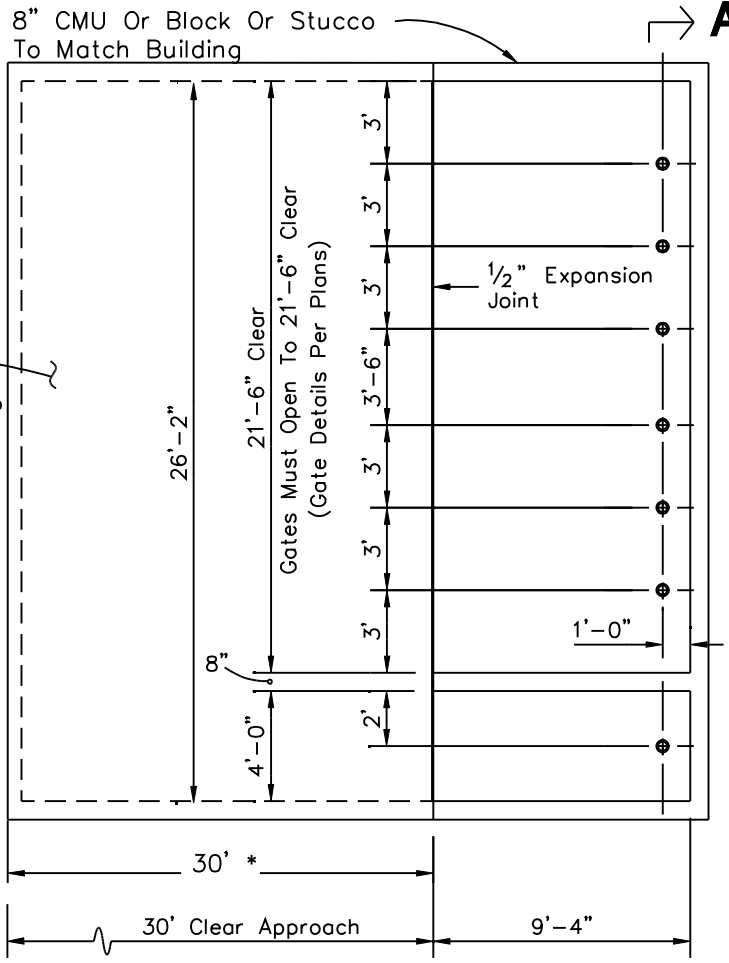

PLAN

* In locations where a 30' approach slab is not possible, approval from the City of Scottsdale Quality Compliance Division is required.

DETAIL NO. **2147-2** **City of Scottsdale Standard Details**

APPROVED BY: **Scottsdale Standards & Specifications Committee**

DOUBLE REFUSE ENCLOSURE W/ GREASE CONTAINMENT AREA

DETAIL NO. **2147-2**

REVISED 4/12/05

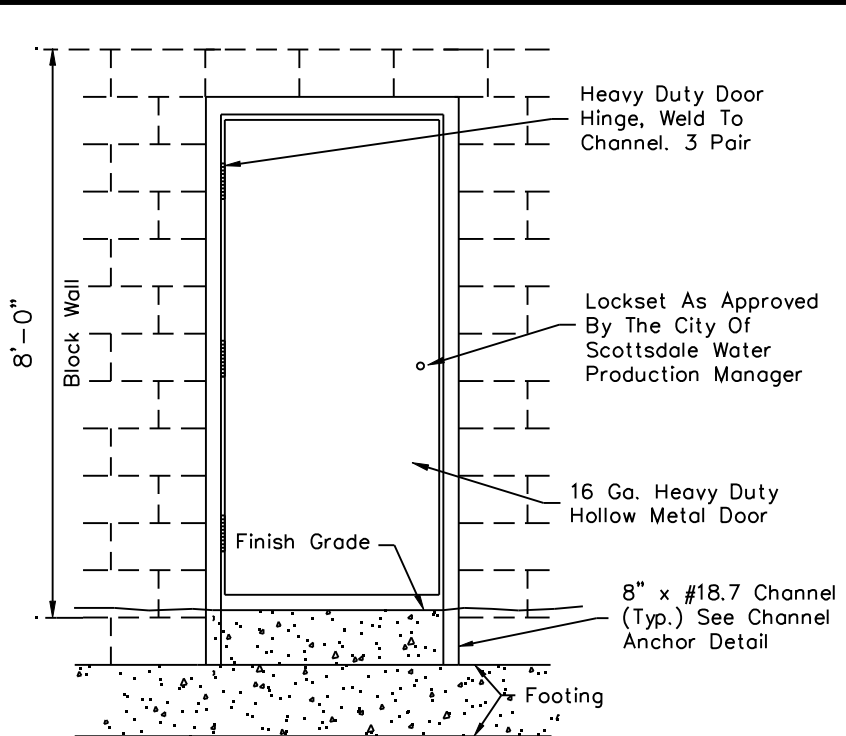

HINGED DOOR

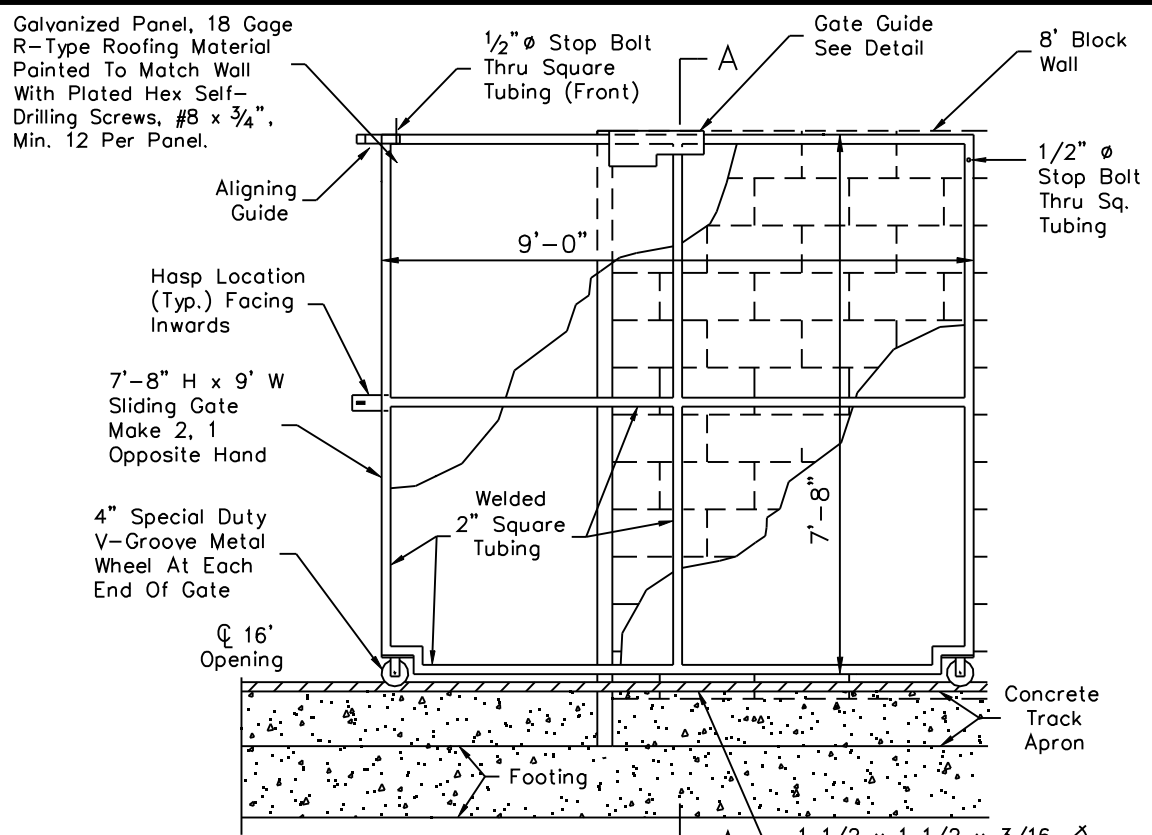

ELEVATION

1 1/2 x 1 1/2 x 3/16 Δ Track, 18' Long Each Side Of Opening C And 4" From Wall Face. Anchor Per Section A-A.

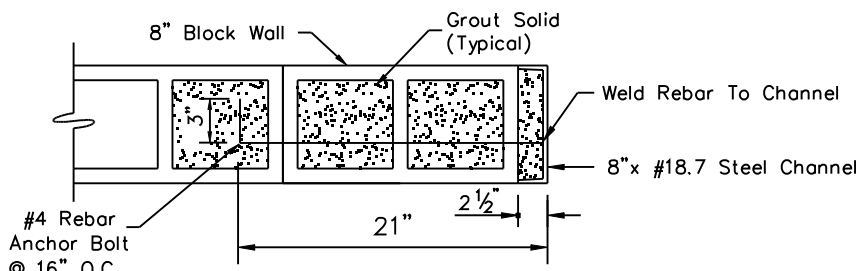

CHANNEL ANCHOR DETAIL

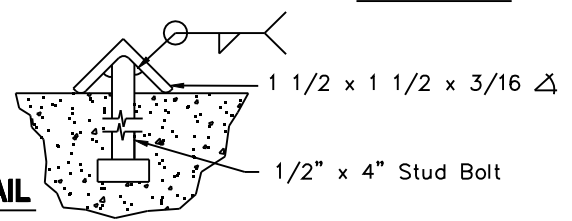

TRACK DETAIL

REVISED 4/12/05

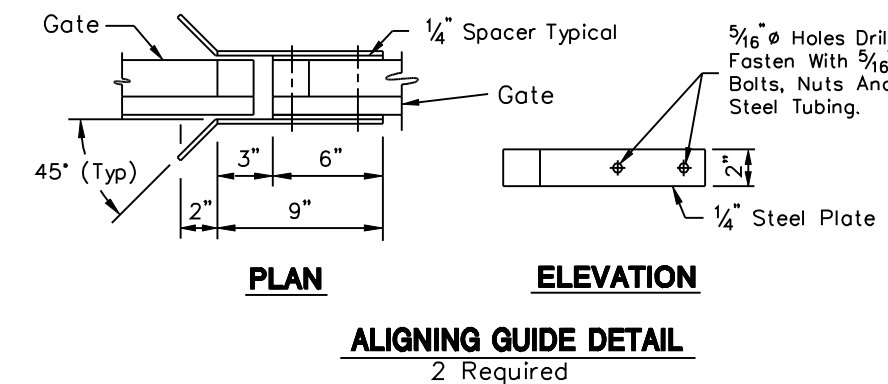
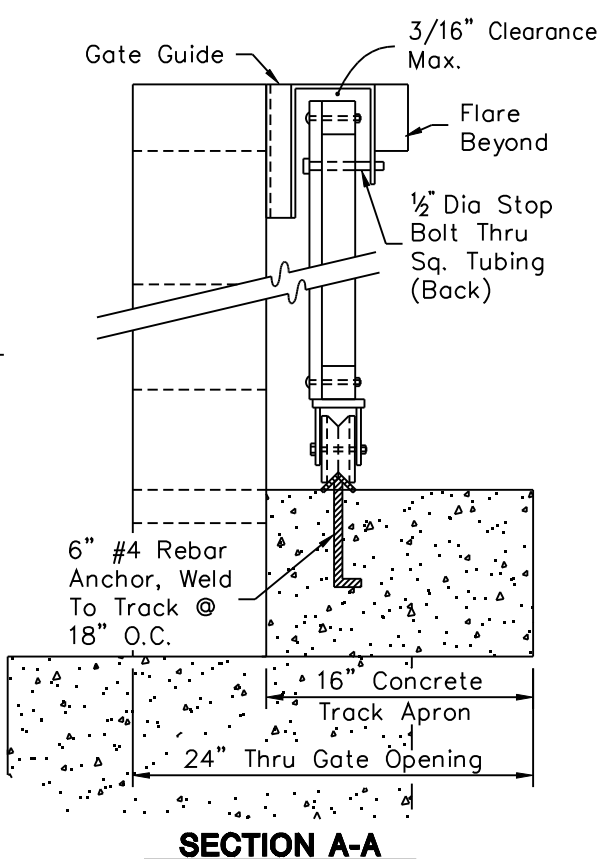
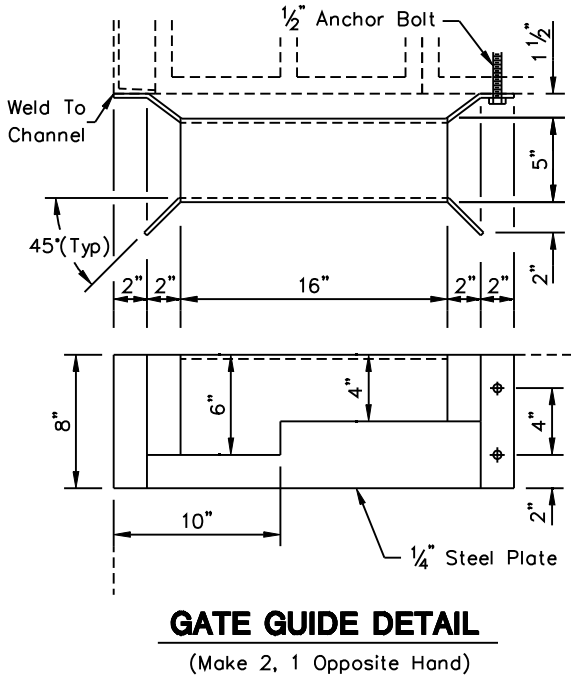
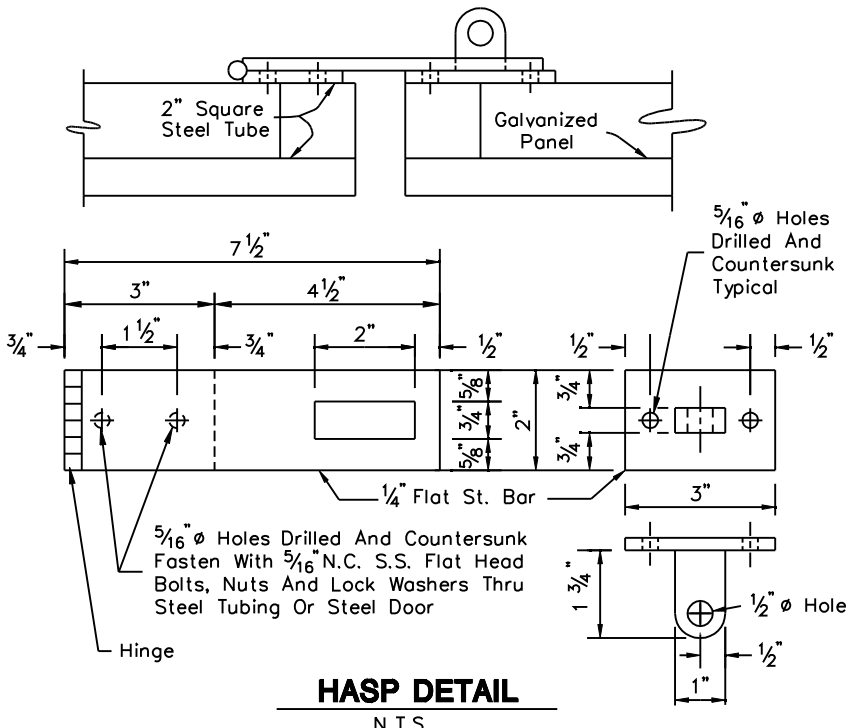

NOTES:

1. Contractor shall prime and paint all metal surfaces. Before application, the color and manufacturer of the paint shall be approved by the City.
2. Prior to painting, all surfaces shall be cleaned free of concrete, mortar, rust, dirt and any other objectionable materials.
3. Apply one (1) primer coat and two (2) exterior alkyd gloss enamel coats to metal.

DETAIL NO. 2165-2	City of Scottsdale Standard Details	APPROVED BY: Scottsdale Standards & Specifications Committee	16' SLIDING GATE	DETAIL NO. 2165-2
-----------------------------	--	--	-------------------------	-----------------------------

REVISED 7/15/03

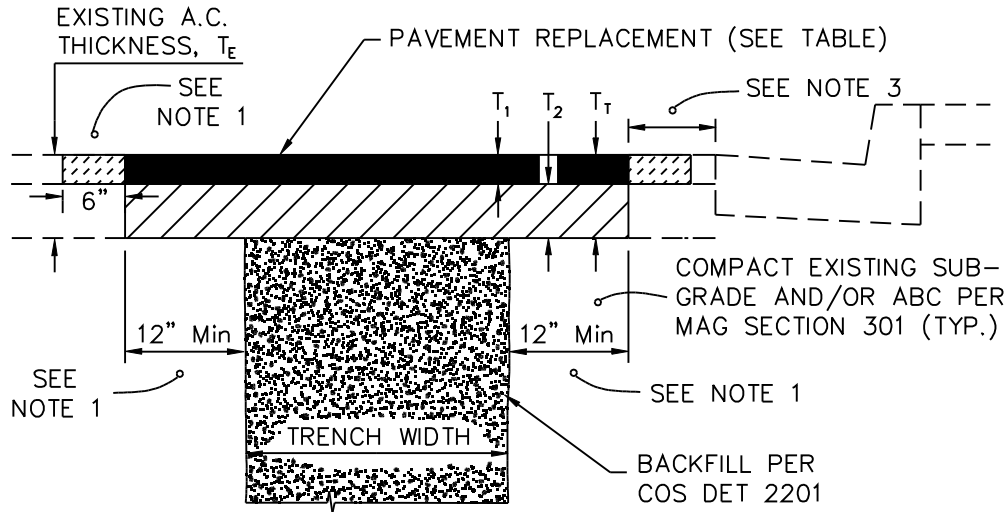

PAVEMENT REPLACEMENT FOR TRENCHES (T-TOP)

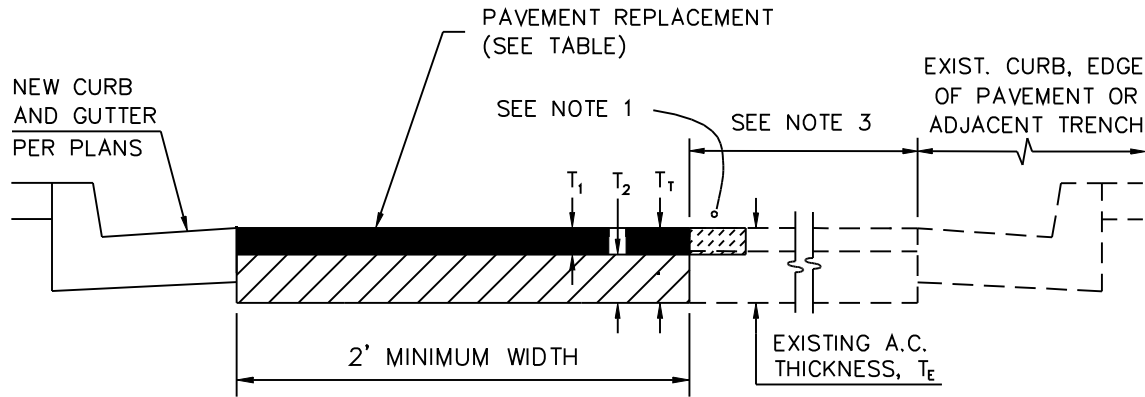

PAVEMENT REPLACEMENT

EXISTING PAVEMENT THICKNESS, T_E	AC PAVEMENT REPLACEMENT TABLE		
	AC SINGLE COURSE OR SURFACE COURSE, T_1	AC BASE COURSE, T_2	TOTAL THICKNESS, T_T
$T_E \leq 3"$	3" MINIMUM	NONE	3" MINIMUM
$T_E > 3"$	2" MINIMUM	2" MINIMUM	T_E (MATCH EXIST)

PAVEMENT REPLACEMENT NOTES

1. "T"-TOP REQUIRED FOR ALL TRENCHES. A.C. SURFACE COURSE REPLACEMENT TO BE MILLED DOUBLE "T" CONFIGURATION AS SPECIFIED BELOW FOR PAVEMENTS 4" AND THICKER.
 - a. FOR PAVEMENT 4 YEARS AND OLDER: INITIAL A.C. REMOVAL TO BE THE MINIMUM WIDTH REQUIRED FOR PROPER TRENCH COMPACTION. SAWCUT & REMOVE 12" OF A.C. MINIMUM ON EACH SIDE OF THE TRENCH FOR THE "T"-TOP AFTER THE BACKFILL MATERIAL IS PLACED. PAVEMENTS 4" AND THICKER, MILL AND REMOVE THE TOP 2" OF THE SURFACE COURSE A MINIMUM OF 6" ON EACH SIDE OF THE T-TOP PRIOR TO PLACEMENT OF THE FINAL SURFACE COURSE LIFT.
 - b. FOR NEW AND OVERLAYED PAVEMENT LESS THAN 4 YEARS OLD AND WHEN ALLOWED UNDER THE PROVISIONS OF SCOTTSDALE REVISED CODE SECTIONS 47-79 AND ALL PAVEMENTS WITH RUBBERIZED SURFACE COURSES: INITIAL A.C. REMOVAL TO BE THE MINIMUM WIDTH REQUIRED FOR PROPER TRENCH COMPACTION. SAWCUT & REMOVE 12" OF A.C. MINIMUM ON EACH SIDE OF THE TRENCH FOR THE "T"-TOP AFTER THE BACKFILL MATERIAL IS PLACED. PAVEMENTS 4" AND THICKER, MILL AND REMOVE THE TOP 2" OF THE SURFACE COURSE EQUALLY ON BOTH SIDES OF THE TRENCH TO A MINIMUM TOTAL WIDTH OF 10 FEET. FOR PAVEMENTS LESS THAN 4" THICK SAWCUT, REMOVE AND REPLACE THE ENTIRE PAVEMENT SURFACE TO A MINIMUM TOTAL WIDTH OF 10 FEET, AS DIRECTED BY THE ENGINEER.
 - c. FOR DEEP PAVEMENT STRUCTURES REQUIRING TWO OR MORE PAVEMENT BASE LIFTS: INITIAL A.C. REMOVAL TO BE THE MINIMUM WIDTH REQUIRED FOR PROPER TRENCH COMPACTION. SAWCUT, REMOVE AND REPLACE A.C. ON BOTH SIDES OF THE TRENCH AS NECESSARY TO ACCOMMODATE A RIDE ON TYPE VIBRATORY ROLLER COMPACTOR FOR PLACEMENT OF THE A.C. BASE COURSE LIFTS, MATCH EXISTING A.C. DEPTH. MILL AND REMOVE THE TOP 2" OF THE SURFACE COURSE EQUALLY ON BOTH SIDES OF THE TRENCH TO A MINIMUM TOTAL WIDTH OF 10 FEET.
2. ASPHALT CONCRETE SHALL BE IN ACCORDANCE WITH THE REQUIREMENTS OF MAG SECTION 321.
3. IF PAVEMENT REMNANT IS LESS THAN 36", REMOVE AND REPLACE PAVEMENT AS PER THIS DETAIL.
4. AGGREGATE BASE COURSE PER MAG SECTION 702 SHALL BE PROVIDED TO MATCH EXISTING ABC THICKNESS IN ADJACENT ROADWAY.
5. REFER TO COS SUPPLEMENTAL SPECIFICATIONS, SECTION 336.2.4 FOR PAVEMENT SMOOTHNESS REQUIREMENTS.

DETAIL NO.
2200

City of Scottsdale
Standard Details

APPROVED BY:
Scottsdale Standards & Specifications Committee

PAVEMENT REPLACEMENT

DETAIL NO.
2200

REVISED 4/15/09

BACKFILL DETAILS

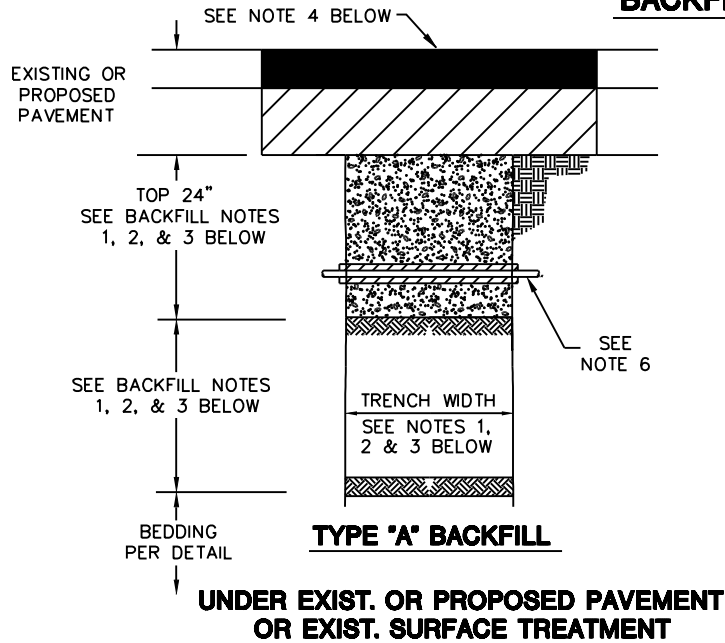

TYPE 'A' BACKFILL

**UNDER EXIST. OR PROPOSED PAVEMENT
OR EXIST. SURFACE TREATMENT**

BACKFILL NOTES

1. TRENCHES LESS THAN 24" IN WIDTH - 1/2 SACK CLSM, MAG 728, FULL DEPTH OF BACKFILL BOTTOM OF ABC LAYER IN PAVEMENT STRUCTURE OR 6" BELOW PAVEMENT IN FULL DEPTH PAVEMENT STRUCTURES. CONSTRUCT PAVEMENT STRUCTURE TO MATCH EXISTING AND IN ACCORDANCE WITH COS DETAIL 2200.
2. TRENCHES 24" TO 6' IN WIDTH - 1/2 SACK CLSM AS DESCRIBED IN NOTE 1 ABOVE WITHIN THE TOP 24" OF THE TRENCH; MAG 601.4.3 FOR BALANCE OF BACKFILL.
3. TRENCHES OVER 6' IN WIDTH - MAG 601.4.3 FULL DEPTH OF BACKFILL.
4. TREAT ENTIRE DISTURBED SURFACE OF UNPAVED ALLEYS WITH LIGNIN-BASED DUST PALLATIVE, MAG 792, 1:1 DILUTION RATIO, 0.50 GAL/SY APPLICATION RATE.
5. CLSM SHALL NOT BE USED FOR WATER OR SEWER PIPE BEDDING. SEE BEDDING DETAIL.
6. EXPOSED COPPER OR POLYETHYLENE WATER PIPES IN SIZES 3/4" TO 2" SHALL BE WRAPPED WITH 3/4" WIDE BLACK INSULATION BEFORE PLACING CLSM.
7. RECYCLED ASPHALT SHALL NOT BE USED FOR BACKFILL.

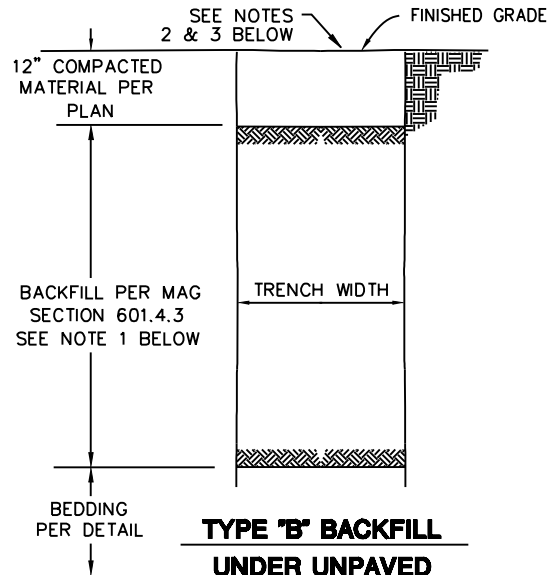

TYPE 'B' BACKFILL

**UNDER UNPAVED
ROADWAY, PARKING LOT
AND VACANT LAND**

BACKFILL NOTES

1. MAG 601.4.3 FULL DEPTH OF BACKFILL.
2. ENTIRE DISTURBED EXISTING SURFACE TO BE RESTORED WITH A LIKE MATERIAL.
3. TREAT ENTIRE DISTURBED SURFACE WITH LIGNIN-BASED DUST PALLATIVE, MAG 792, 1:1 DILUTION RATIO, 0.50 GAL/SY APPLICATION RATE.
4. RECYCLED ASPHALT SHALL NOT BE USED FOR BACKFILL.

BEDDING DETAILS

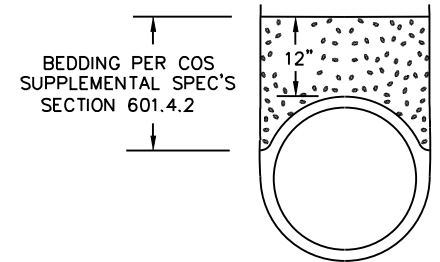

**BEDDING DETAIL
CAST-IN-PLACE PIPE**

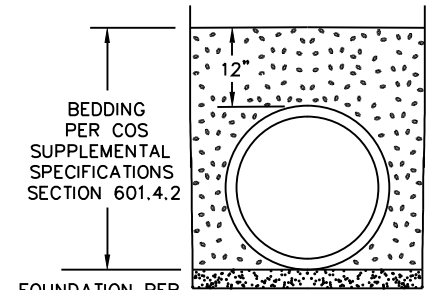

**BEDDING DETAIL
ALL OTHER PIPE**

NOTES:

1. FOR HDPE PIPE - SEE COS SUPPLEMENTAL SPECIFICATIONS SECTION 603.4.2.
2. RECYCLED ASPHALT SHALL NOT BE USED FOR BEDDING OR FOUNDATION MATERIAL.

DETAIL NO.
2201

**City of Scottsdale
Standard Details**

APPROVED BY:
**Scottsdale Standards &
Specifications Committee**

TRENCH BEDDING & BACKFILL

DETAIL NO.
2201

REVISED: 4/25/02

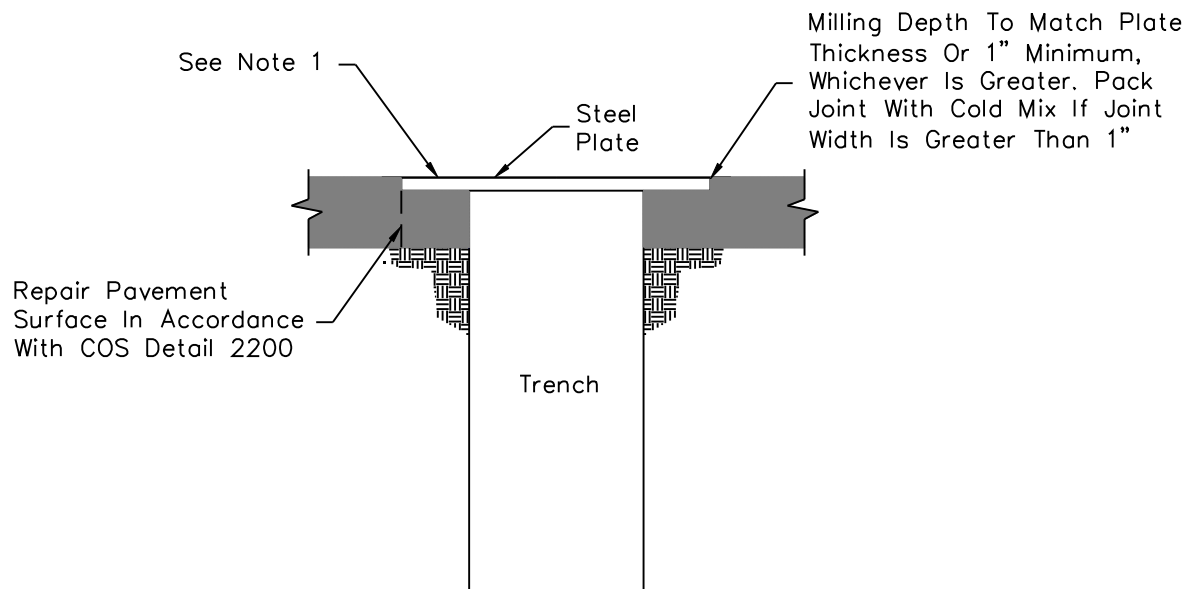

TYPE 'A' PLATING

CITY POSTED SPEEDS OF
35 MPH AND GREATER
OR BUS & TRUCK ROUTE

NOTES:

1. The contractor shall provide adequate overlap of plate on asphalt to assure no slippage of plate and no collapsing of trench.
2. "Posted Speed" does not include temporary construction signing.

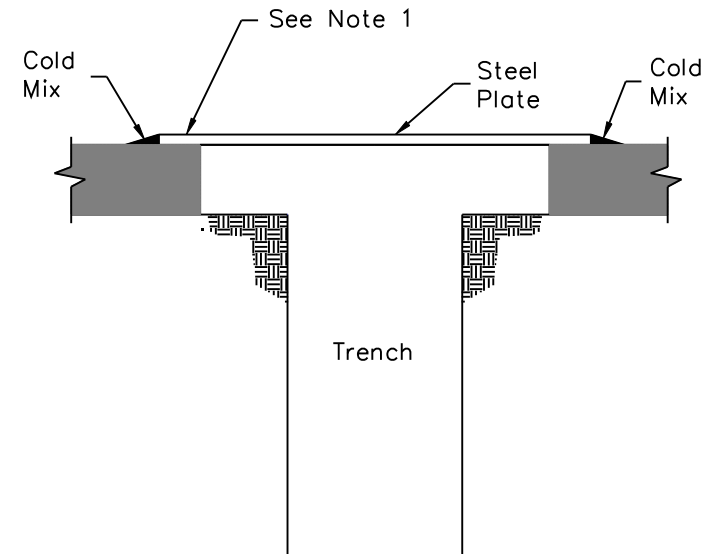

TYPE 'B' PLATING

CITY POSTED SPEEDS
UNDER 35 MPH

DETAIL NO.
2202

**City of Scottsdale
Standard Details**

APPROVED BY:
**Scottsdale Standards &
Specifications Committee**

TRENCH PLATING

DETAIL NO.
2202

REVISED: 3/28/02

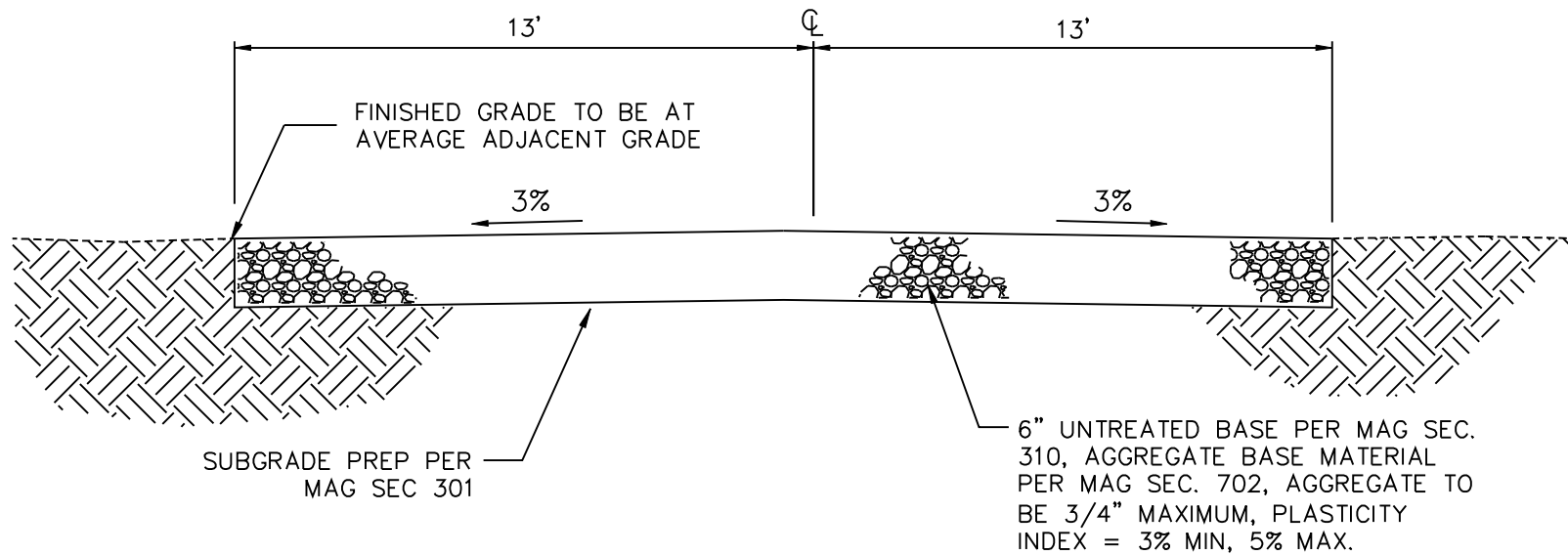

UNPAVED ROAD DETAIL

DETAIL NO. **2207** **City of Scottsdale**
Standard Details

APPROVED BY:
Scottsdale Standards & Specifications Committee

RESIDENTIAL UNPAVED ROAD

DETAIL NO. **2207**

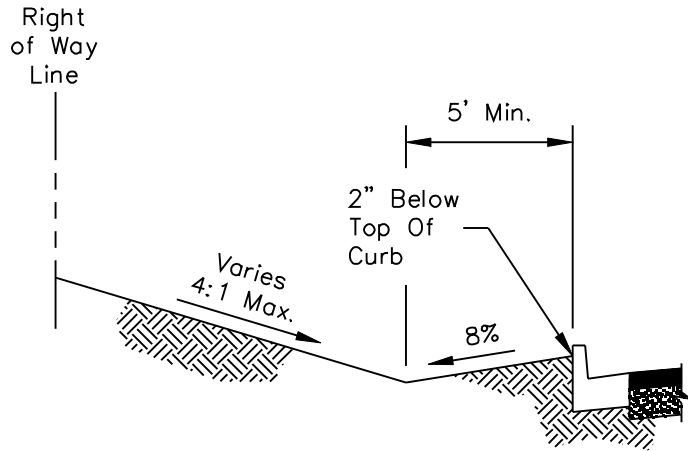

NO SIDEWALK

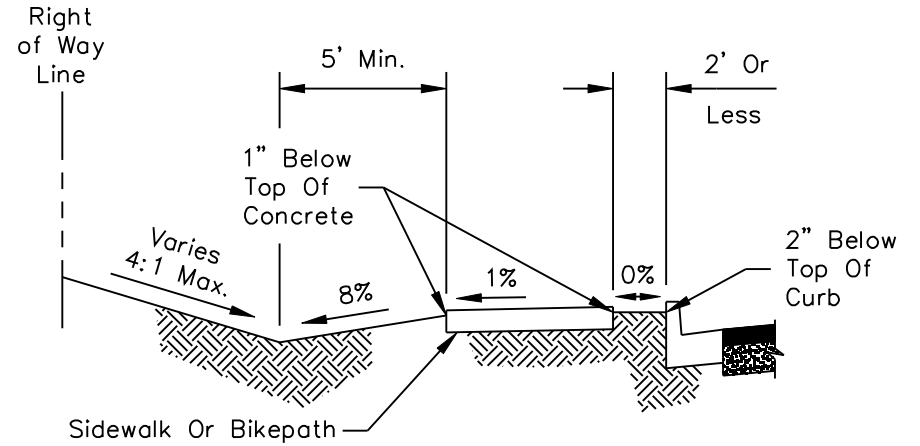

SIDEWALK LESS THAN 2' BEHIND CURB

NOTE:
Runoff Shall Not Be Directed To Cross Over The Top Of A Sidewalk.

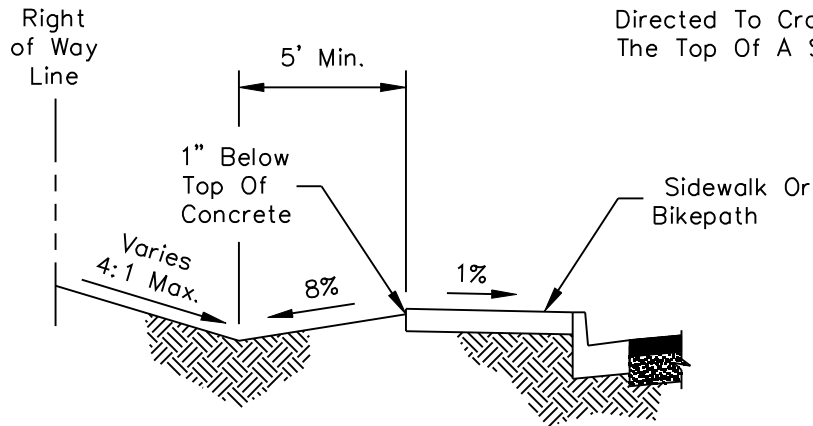

SIDEWALK AT BACK OF CURB

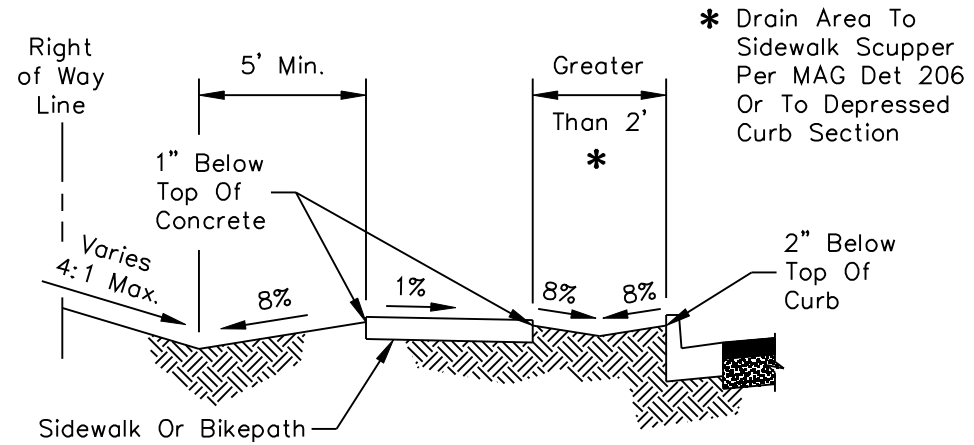

SIDEWALK MORE THAN 2' BEHIND CURB

DETAIL NO.
2210

**City of Scottsdale
Standard Details**

APPROVED BY:
**Scottsdale Standards &
Specifications Committee**

GRADING BEHIND THE CURB

DETAIL NO.
2210

REVISED 4/15/09

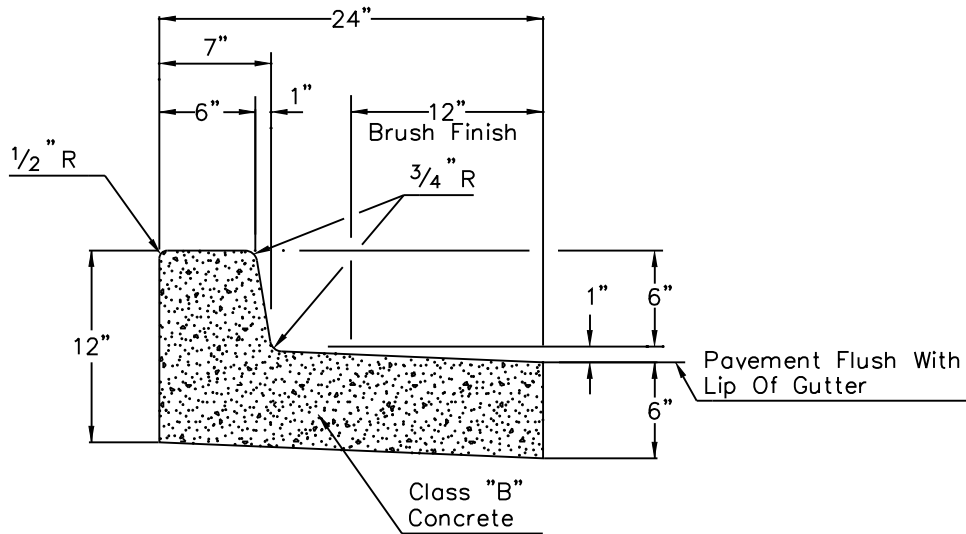

**VERTICAL CURB & GUTTER
WITH DEPRESSED LIP**

TYPE 'A'

NOTES

1. All exposed surfaces to be trowel finished except as shown. See M.A.G. Section 340.
2. Contraction joint spacing shall be 10' maximum or as directed by the Inspector.
3. Construct curb and install 1/2" mastic expansion joints, A.S.T.M. D-1751, per M.A.G. Sec. 340 & 729 and COS Sec. 340.
4. Colored concrete shall be colored integrally.

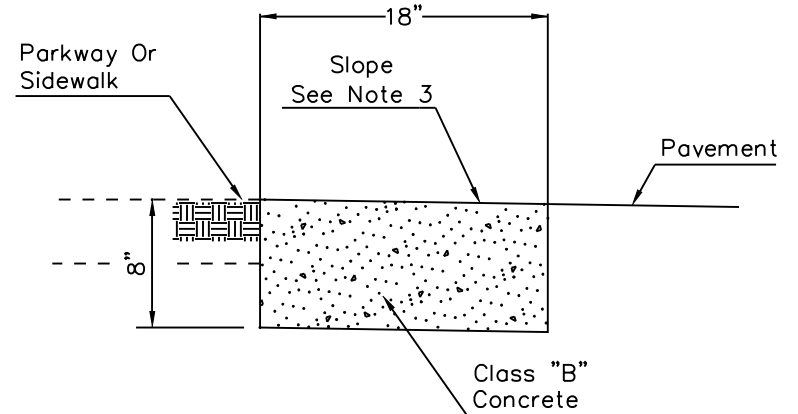

**RIBBON CURB
TYPE 'B'**

NOTES

1. Construct curb and install 1/2" mastic expansion joints, A.S.T.M. D-1751, per M.A.G. Sec. 340 & 729 and COS Sec 340.
2. Broom finish all surfaces.
3. Ribbon curb may slope towards pavement or parkway. Match cross slope of road unless indicated otherwise on plans.
4. Contraction joint spacing shall be 10' maximum or as directed by the Inspector.
5. Colored concrete shall be colored integrally.

DETAIL NO.
2220

**City of Scottsdale
Standard Details**

APPROVED BY:
**Scottsdale Standards &
Specifications Committee**

CURB AND GUTTER - TYPES A & B

DETAIL NO.
2220

REVISED 4/15/09

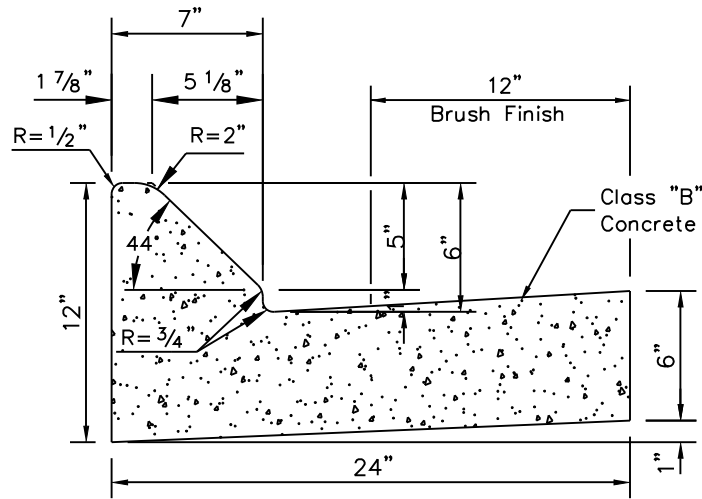

**MOUNTABLE/MEDIAN CURB & GUTTER
TYPE "M"**

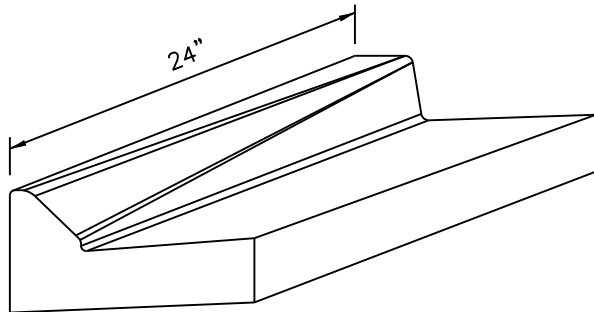

MOUNTABLE CURB TO VERTICAL CURB TRANSITION

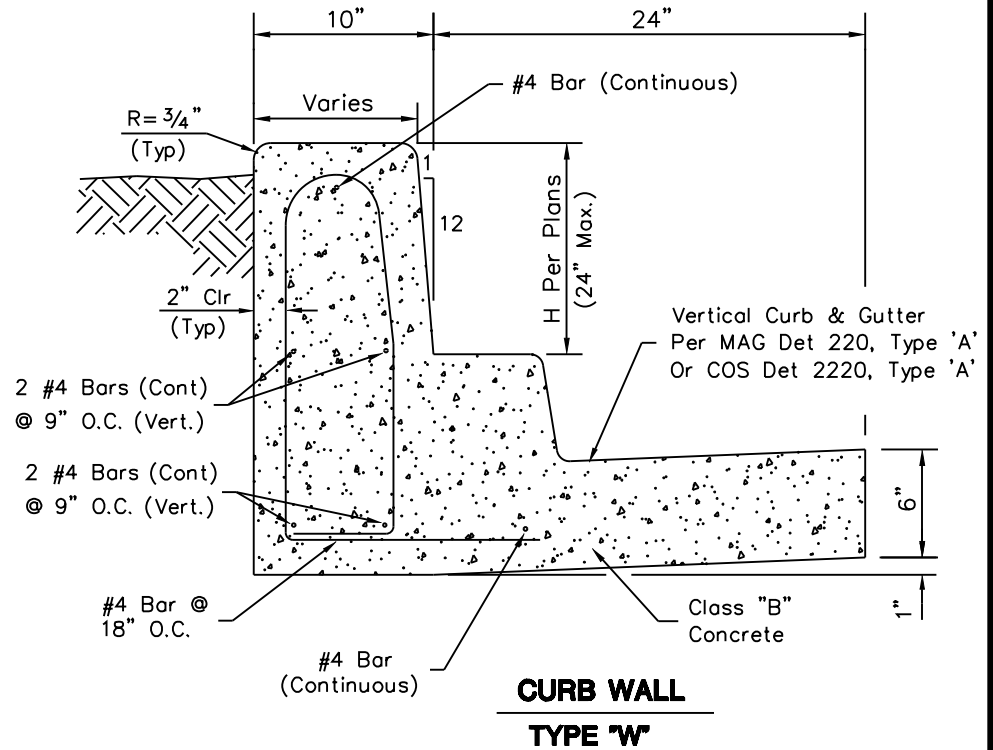

**CURB WALL
TYPE "W"**

NOTES

1. All exposed surfaces to be trowel finished except as shown. See M.A.G. Section 340.
2. Contraction joint spacing shall be 10' maximum or as directed by the Inspector.
3. Construct curb and install 1/2" mastic expansion joints, A.S.T.M. D-1751, per M.A.G. Sec. 340 & 729 and C.O.S. Sec. 340.
4. Gutter lip may be depressed where indicated on plans and constructed as shown on COS Detail 2220, Type "A".
5. Colored concrete, if called for on the plans, shall be colored integrally.
6. Steel reinforcement shall be per M.A.G. Section 727.

DETAIL NO.
2221

**City of Scottsdale
Standard Details**

APPROVED BY:
**Scottsdale Standards &
Specifications Committee**

CURB & GUTTER - TYPES M & W

DETAIL NO.
2221

MEDIAN NOSE CURVE DATA

CURVE	RADIUS*	LENGTH	TANGENT	CHORD	DELTA
C1	59.5'	19.06'	9.61'	18.97'	18°20'59"
C2	0.50'	1.41'	3.10'	0.99'	161°39'01"

 Paint Top And Front Of Curb With Reflectorized Yellow Traffic Paint And Add Type "D" Yellow Two Way Reflective Raised Pavement Markers To Median Nose, Spaced At 5-feet.

Note: Extend Median Treatment To A Width Of 6 Feet Or As Shown On The Plans.

140' RC for 55-65 mph
 90' RC for 40-50 mph
 60' RC for 25-35 mph

REVISED 3/11/09

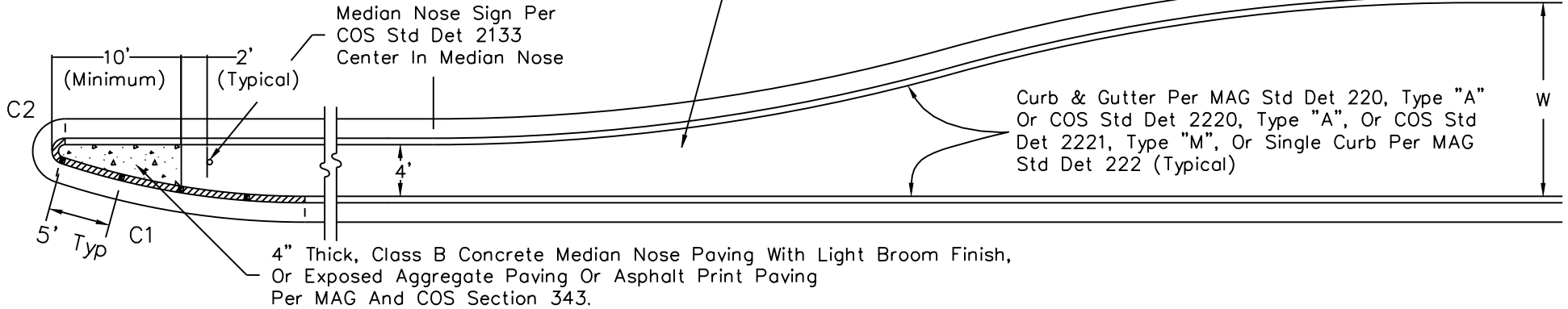

* ALL RADII AND DIMENSIONS TO BACK OF CURB

NOTE: Curve Data Shown Is For Streets On Linear Alignments Only.

DETAIL NO.
2225

City of Scottsdale
Standard Details

APPROVED BY:
Scottsdale Standards & Specifications Committee

MEDIAN NOSE & REVERSE CURVE DETAILS

DETAIL NO.
2225

REVISED 3/11/09

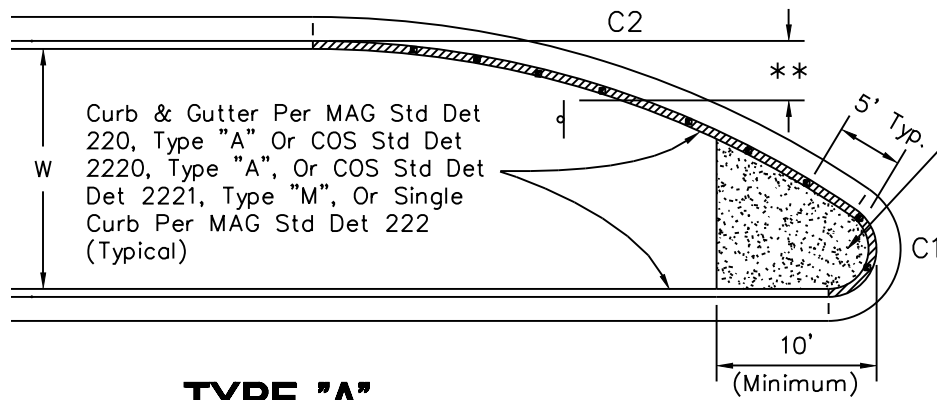

TYPE "A"

Paint Top And Front Of Curb With ReflectORIZED Yellow Traffic Paint And Add Type "D" Yellow Reflective Raised Pavement Markers to Median Nose, Spaced at 5-feet.

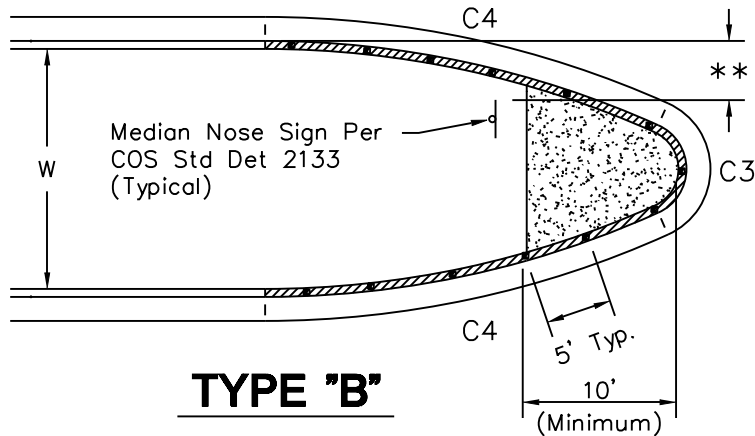

TYPE "B"

4" Thick, Class B Concrete Median Nose Paving With Light Broom Finish, Or Exposed Aggregate Paving or Asphalt Print Paving per MAG and COS Section 343 (Typical)

* ALL RADII AND DIMENSIONS TO BACK OF CURB

** OFFSET TO BE NO MORE THAN 3' FROM FACE OF CURB TANGENT TO EDGE OF SIGN

* CURVE DATA - W=15'

CURVE	RADIUS	LENGTH	TANGENT	CHORD	DELTA
C1	2.50'	6.35'	8.06'	4.78'	145°32'39"
C2	59.50'	35.78'	18.45'	35.24'	34°27'21"
C3	2.50'	5.74'	5.57'	4.56'	131°38'42"
C4	59.50'	25.11'	12.74'	24.92'	24°10'39"

* CURVE DATA - W=16'

CURVE	RADIUS	LENGTH	TANGENT	CHORD	DELTA
C1	2.50'	6.27'	7.65'	4.75'	143°48'20"
C2	59.50'	37.59'	19.44'	36.97'	36°11'40"
C3	2.50'	5.64'	5.27'	4.52'	129°14'46"
C4	59.50'	26.35'	13.40'	26.14'	25°22'37"

* CURVE DATA - W=24'

CURVE	RADIUS	LENGTH	TANGENT	CHORD	DELTA
C1	2.50'	5.75'	5.59'	4.56'	131°48'37"
C2	59.50'	50.04'	26.61'	48.58'	48°11'23"
C3	2.50'	4.93'	3.77'	4.17'	112°53'08"
C4	59.50'	34.85'	17.94'	34.35'	33°33'26"

DETAIL NO.
2226

City of Scottsdale
Standard Details

APPROVED BY:
Scottsdale Standards & Specifications Committee

MEDIAN NOSE DETAILS

DETAIL NO.
2226

REVISED 2/22/99

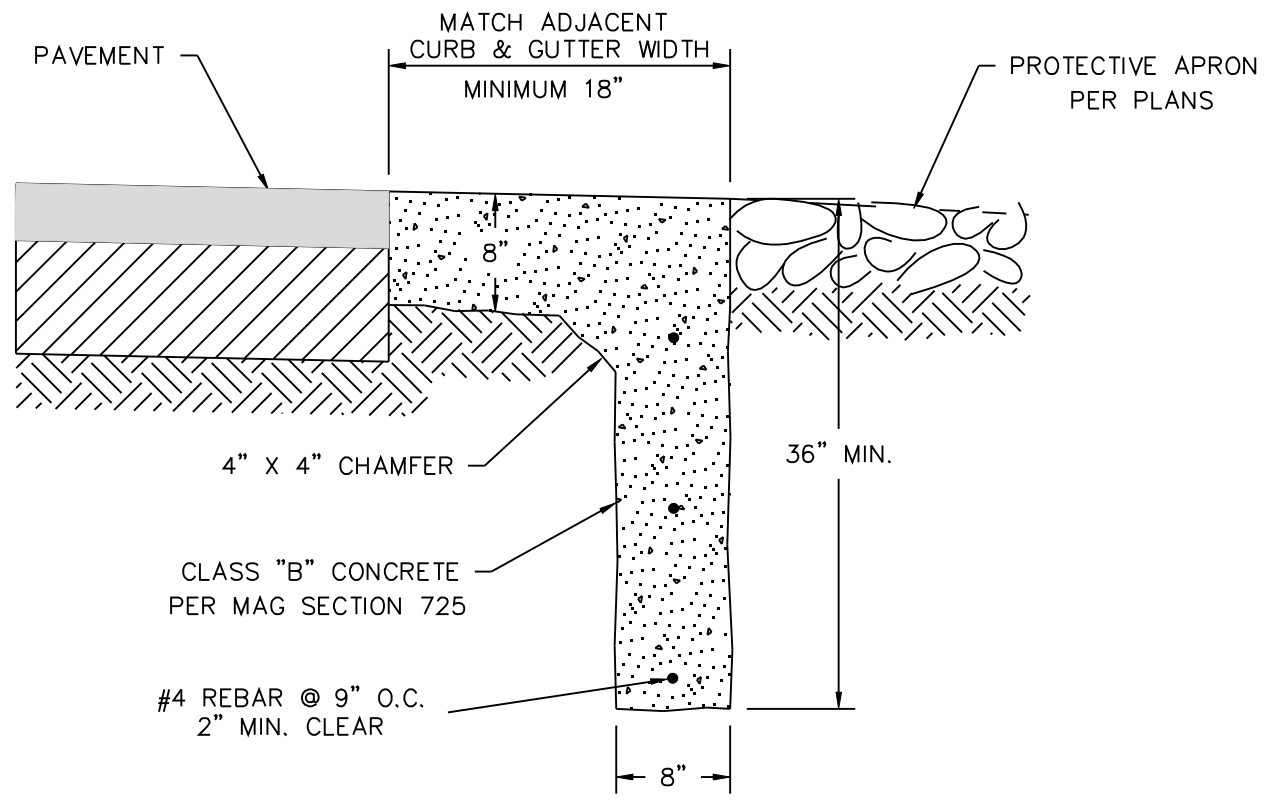

NOTE: Form The Top 8"
Of Cut-Off Wall

DETAIL NO.
2228

City of Scottsdale
Standard Details

APPROVED BY:
Scottsdale Standards & Specifications Committee

CUT-OFF WALL

DETAIL NO.
2228

REVISED 4/18/05

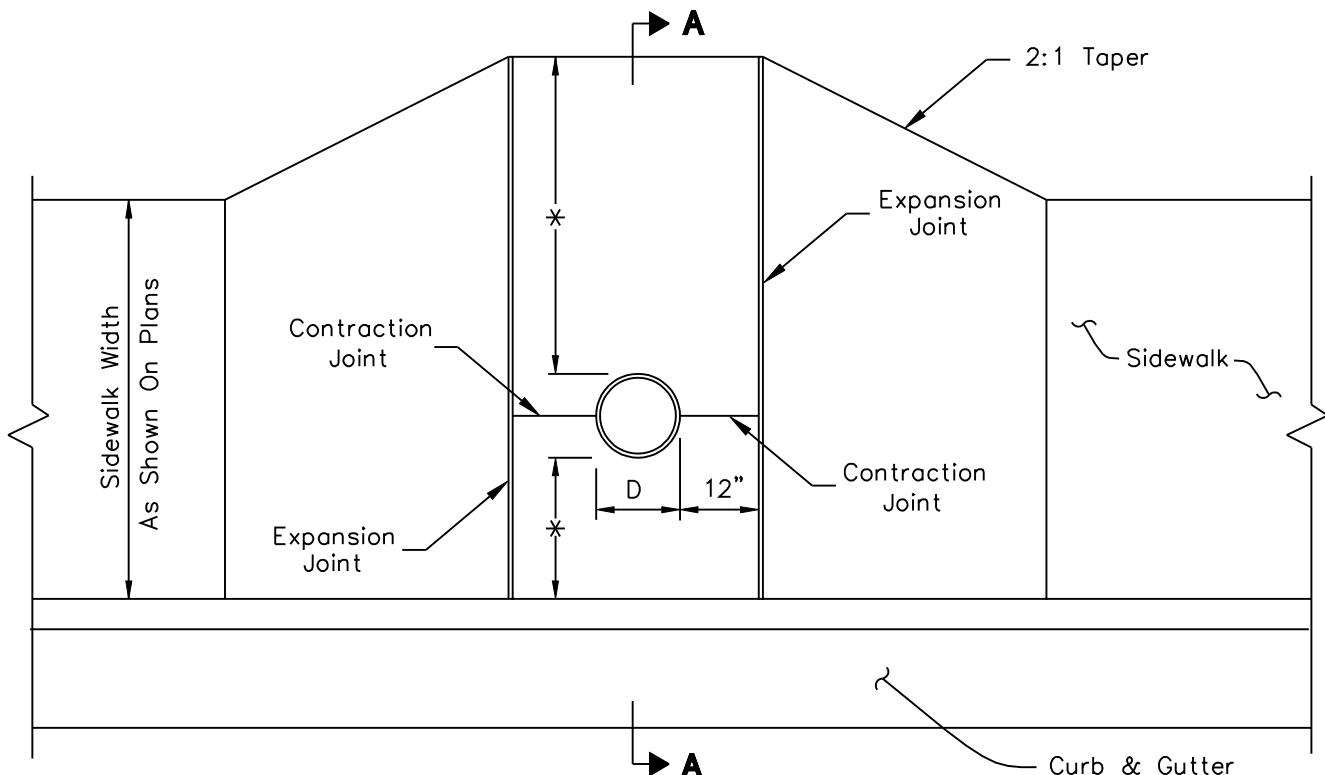

NOTES

Install expansion joint around wood pole.

Install expansion joint at sidewalk 1/4" lower than sidewalk

* Maintain 48" clear on one side of utility pole unless otherwise approved by City staff.

D = Pole Diameter
Range: 12"-17"

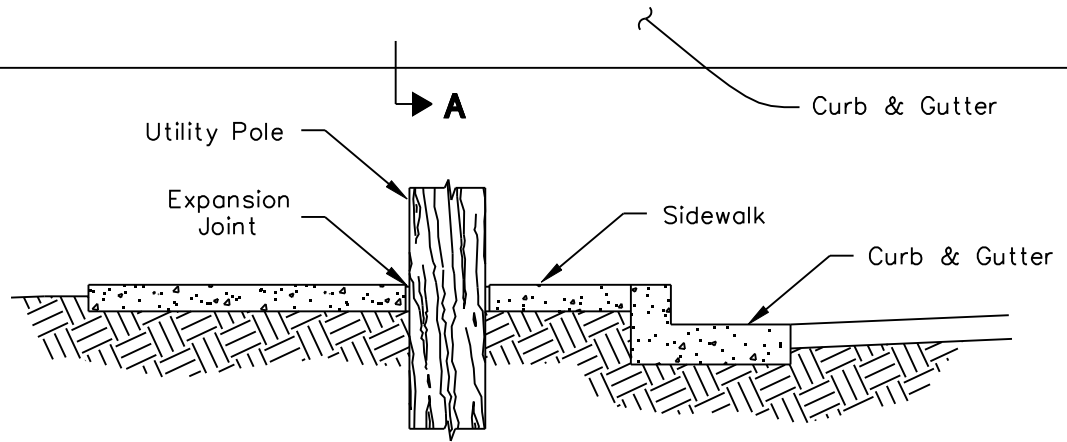

SECTION A-A

DETAIL NO.
2230

**City of Scottsdale
Standard Details**

APPROVED BY:
**Scottsdale Standards &
Specifications Committee**

SIDEWALK CUTOUT FOR UTILITY POLES

DETAIL NO.
2230

REVISED 12/13/11

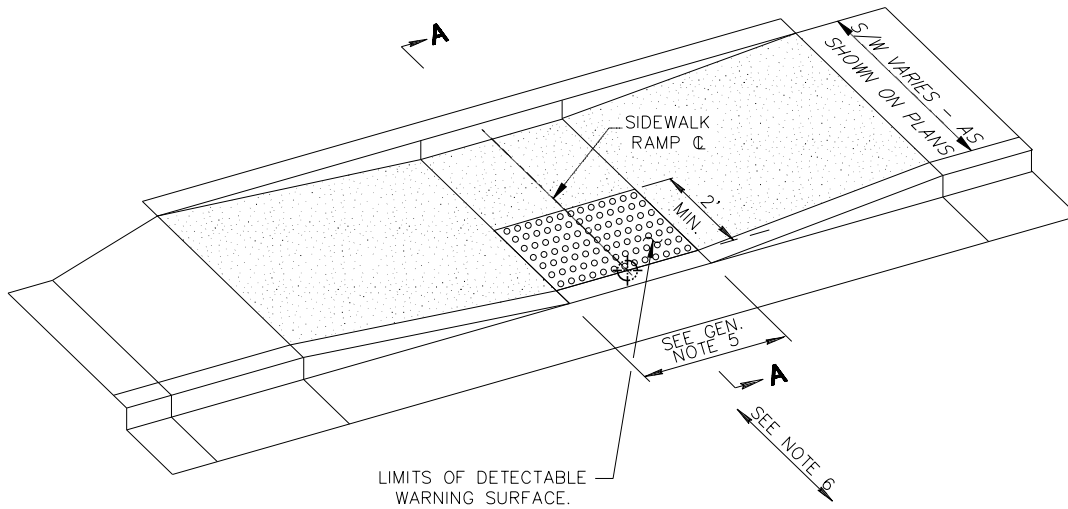

LIMITS OF DETECTABLE WARNING SURFACE.

INSTALLATION EXAMPLE

NTS

⊕ RAMP CONTROL POINT (TYP.) SEE PLANS

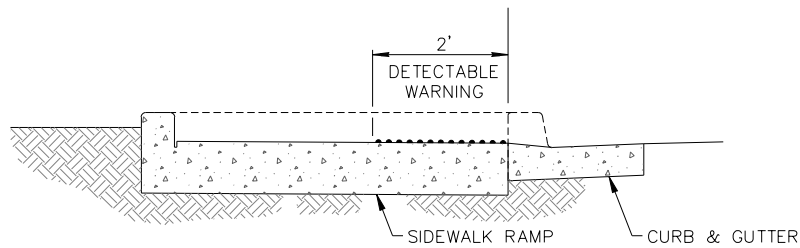

SECTION A-A

NTS

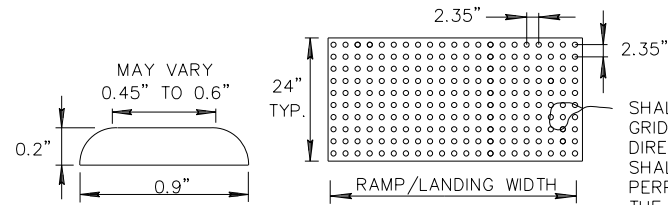

ELEVATION

PLAN VIEW

TRUNCATED DOME DETECTABLE WARNING

NTS

SHALL BE A SQUARE GRID, EQUAL IN BOTH DIRECTIONS. DOMES SHALL BE ALIGNED PERPENDICULAR TO THE CURBLINE AT THE RAMP CONTROL POINT.

GENERAL NOTES

1. DETECTABLE WARNING SURFACE SHALL CONSIST OF RAISED TRUNCATED DOMES, AND SHALL CONFORM TO THE DETAILS IN THE PLANS AND IN ACCORDANCE WITH MANUFACTURER'S SPECIFICATIONS AND INSTALLATION INSTRUCTIONS.
2. ALL DETECTABLE WARNING SURFACES SHALL START AT BACK OF CURB, MEASURE 24 INCHES IN DEPTH AND COVER THE COMPLETE WIDTH OF THE RAMP AREA 48 INCHES MIN..
3. 70% VISUAL CONTRAST IS REQUIRED. THE COLOR SHALL BE AN INTEGRAL PART OF THE DETECTABLE WARNING MATERIAL. COLOR WILL BE SUBJECT TO APPROVAL BY CITY STAFF.
4. THE CONCRETE WORK REQUIRED TO FORM A BLOCK OUT FOR CAST IN PLACE APPLICATIONS, OR TO CREATE A SMOOTH AND CLEAN CONCRETE SURFACE FOR SURFACE APPLICATIONS, SHALL BE INCLUDED IN THE COST OF THE CONCRETE CURB RAMP. THE COST OF FURNISHING AND INSTALLING THE DETECTABLE WARNING DEVICE SHALL BE INCLUDED SEPARATELY AS "DETECTABLE WARNING DEVICE" PER SQUARE FOOT OR AS OUTLINED IN THE SPECIFICATIONS.
5. WIDTH PER RAMP DETAIL OR AS CALLED OUT ON PLANS (4 FEET MINIMUM).
6. ALL RAMPS AND DETECTABLE WARNING SHALL BE ALIGNED PERPENDICULAR TO THE CURB AT THE RAMP CONTROL POINT. SEE PLANS FOR RAMP CONTROL POINT.

APPROVED DETECTABLE WARNING SURFACES

1. ONLY DETECTABLE WARNING SYSTEMS WHICH APPEAR ON THE CITY OF SCOTTSDALE QUALIFIED PRODUCTS LIST ARE APPROVED FOR INSTALLATION. THE QUALIFIED PRODUCT LIST IS LOCATED AT THE FOLLOWING WEBSITE:

WWW.SCOTTSDALEAZ.GOV/STREETS/PRODUCTS/

DETAIL NO.
2231

**City of Scottsdale
Standard Details**

APPROVED BY:
**Scottsdale Standards &
Specifications Committee**

DETECTABLE WARNING SURFACE

DETAIL NO.
2231

REVISED 12/13/11

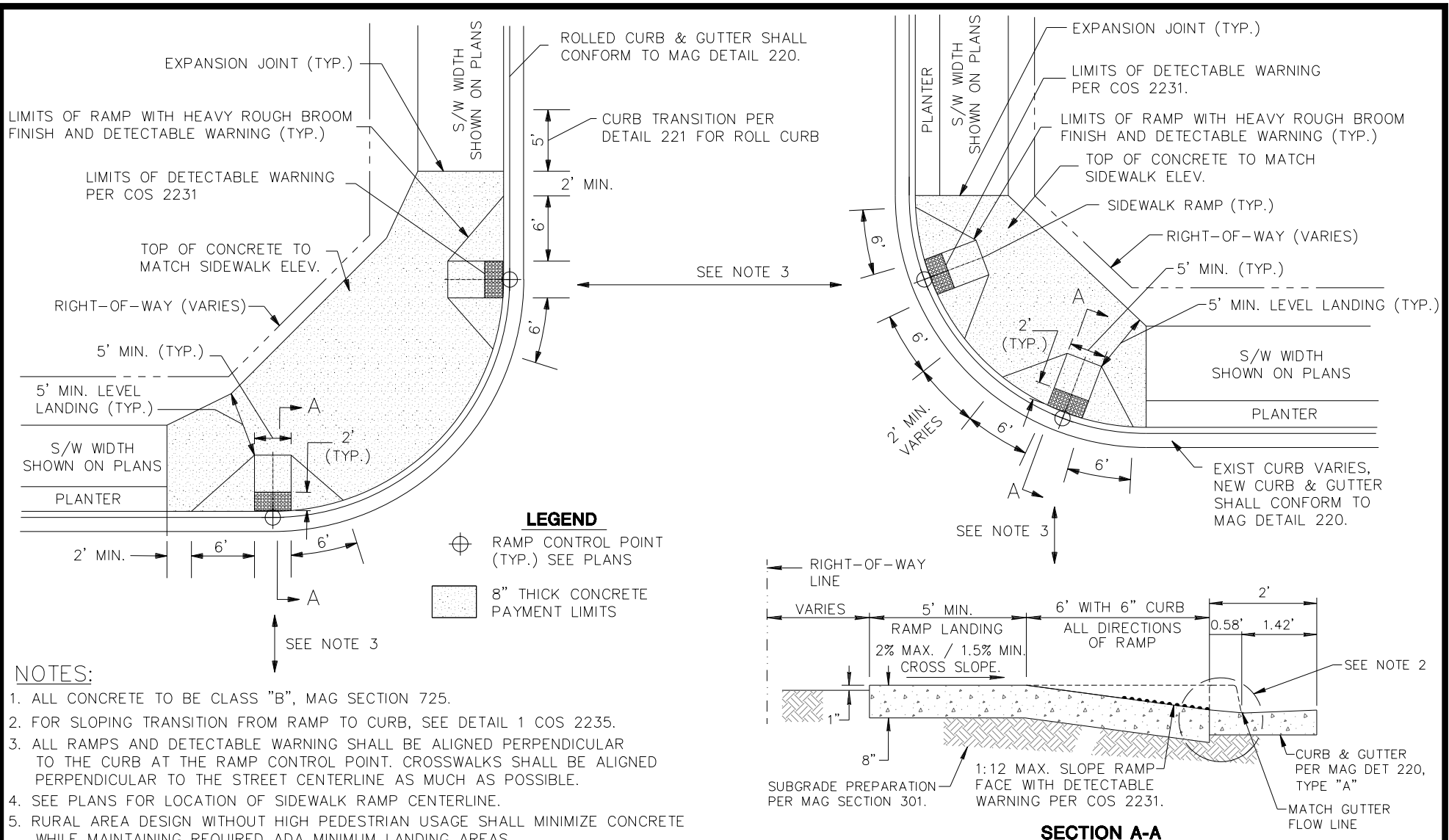

NOTES:

1. ALL CONCRETE TO BE CLASS "B", MAG SECTION 725.
2. FOR SLOPING TRANSITION FROM RAMP TO CURB, SEE DETAIL 1 COS 2235.
3. ALL RAMPS AND DETECTABLE WARNING SHALL BE ALIGNED PERPENDICULAR TO THE CURB AT THE RAMP CONTROL POINT. CROSSWALKS SHALL BE ALIGNED PERPENDICULAR TO THE STREET CENTERLINE AS MUCH AS POSSIBLE.
4. SEE PLANS FOR LOCATION OF SIDEWALK RAMP CENTERLINE.
5. RURAL AREA DESIGN WITHOUT HIGH PEDESTRIAN USAGE SHALL MINIMIZE CONCRETE WHILE MAINTAINING REQUIRED ADA MINIMUM LANDING AREAS.

DETAIL NO.
2232

City of Scottsdale
Standard Details

APPROVED BY:
Scottsdale Standards & Specifications Committee

DIRECTIONAL SIDEWALK RAMPS



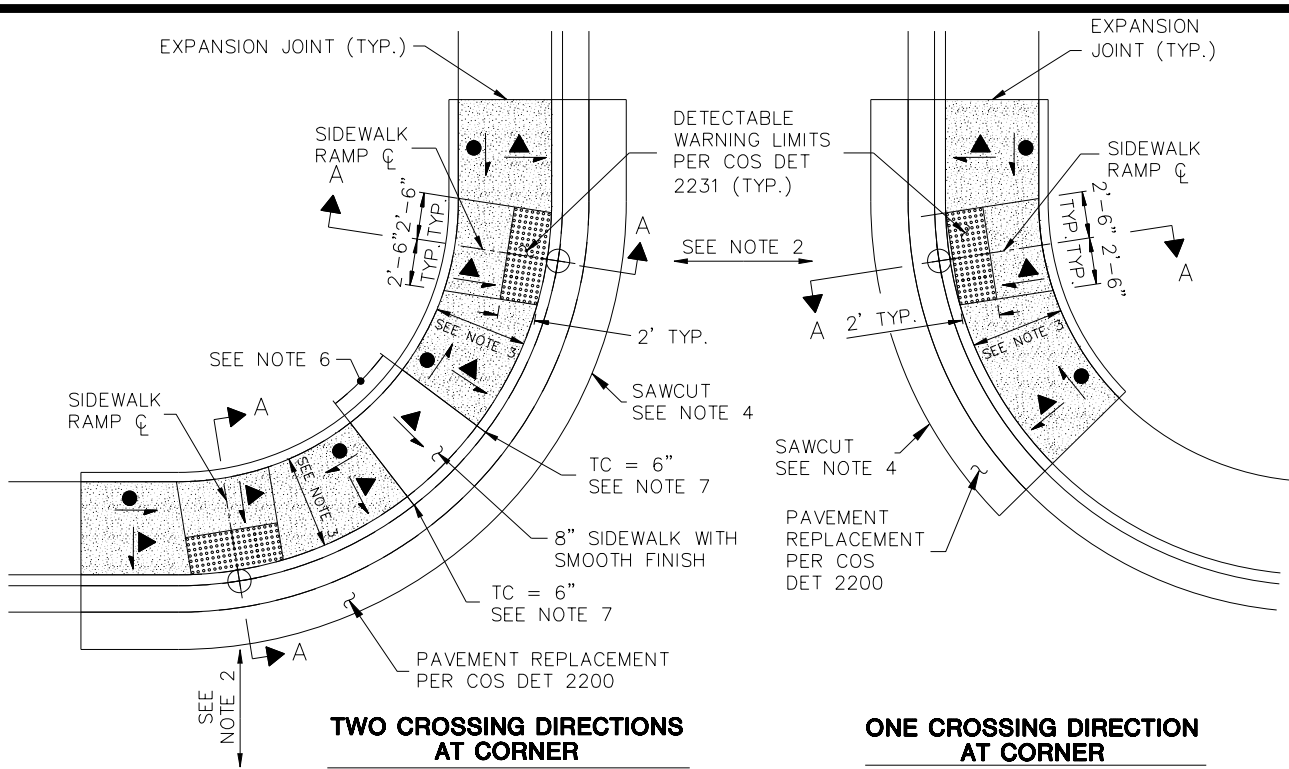

DETAIL NO.
2232

REVISED 12/13/11



- NOTES:**
1. ALL CONCRETE TO BE CLASS "B", MAG SECTION 725.
 2. ALL RAMPS AND DETECTABLE WARNING SHALL BE ALIGNED PERPENDICULAR TO THE CURBLINE AT THE RAMP CONTROL POINT. CROSSWALKS SHALL BE ALIGNED PERPENDICULAR TO THE STREET CENTERLINE AS MUCH AS POSSIBLE.
 3. RAMP LANDING WIDTH SHALL BE 5' PREFERRED, OR ELSE SHALL MATCH EXISTING WIDTH WITH A 4' MINIMUM, AS MEASURED RADIALLY FROM BACK OF CURB TO THE FACE OF RAMP CURB.
 4. WHEN A CONCRETE APRON EXISTS THE SAWCUT MAY BE MADE IN THE APRON 2' FROM BACK OF EXISTING CURB.
 5. SEE PLANS FOR LOCATION OF SIDEWALK RAMP CENTERLINE.
 6. MINIMUM 4' LONG LEVEL AREA REQUIRED BETWEEN RAMPS, 8" THICK.
 7. CURB HEIGHT MAY BE DECREASED TO 4" FOR SPACE LIMITED AREAS PROVIDED THE RAMP SLOPE IS A MAXIMUM 12:1 AND THE MINIMUM 4' LONG LEVEL AREA BETWEEN RAMPS IS MAINTAINED.
 8. PROVIDE 10" MAXIMUM TO FACE OF ANY EXISTING PEDESTRIAN PUSH BUTTON. RAMP CURB AND LANDING MAY NEED TO BE EXTENDED AROUND POLE TO PROVIDE ACCESS TO PUSH BUTTON, OR MOVE BUTTON AS NEEDED.
 9. EACH RAMP RETROFIT REQUIRES A SITE SPECIFIC ASSESSMENT AND FIELD REVIEW BY THE DESIGN ENGINEER TO ENSURE FUNCTIONAL DESIGN.

LEGEND

-  RAMP CONTROL POINT (TYP.) SEE PLANS
-  12:1 MAXIMUM SLOPE, 15:1 DESIRED SLOPE
-  2% MAXIMUM SLOPE, 1.5% MINIMUM SLOPE
-  8" SIDEWALK RAMP PAYMENT LIMITS AND HEAVY ROUGH BROOM FINISH LIMITS

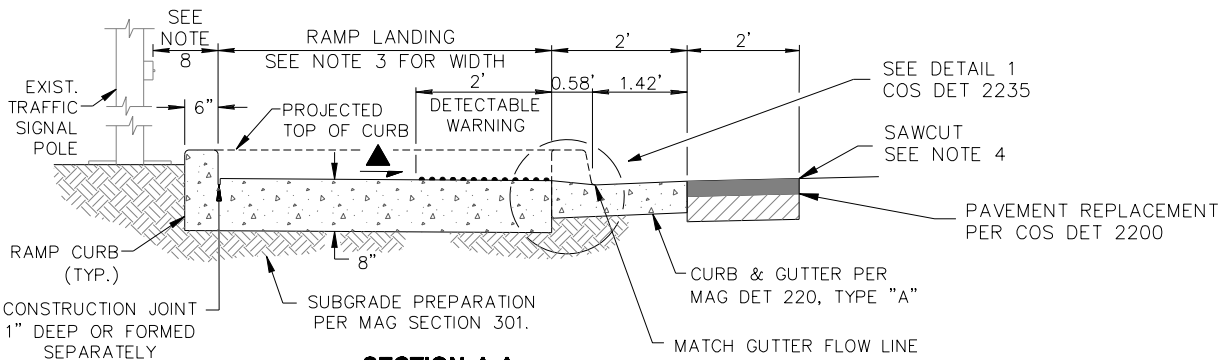

SECTION A-A

DETAIL NO.
2233-1

**City of Scottsdale
Standard Details**

APPROVED BY:
**Scottsdale Standards &
Specifications Committee**

DIRECTIONAL SIDEWALK RAMP RETROFIT - TYPE A

DETAIL NO.
2233-1

REVISED 12/13/11

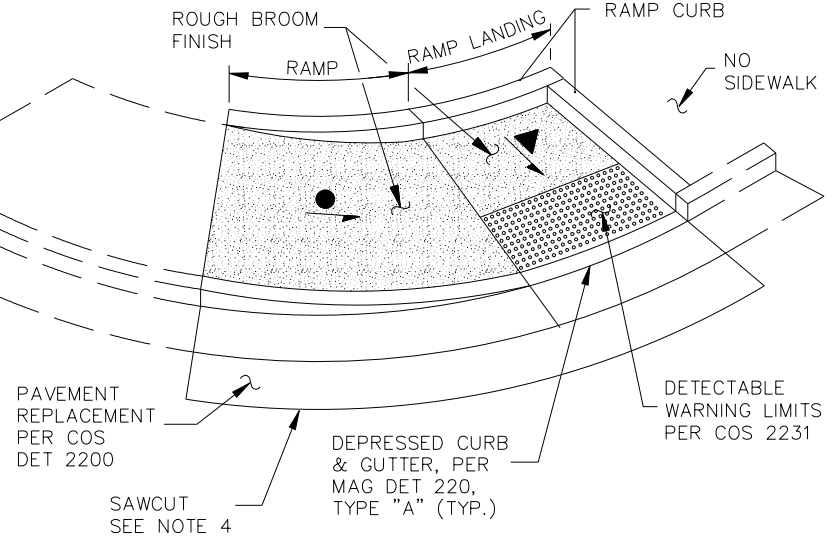
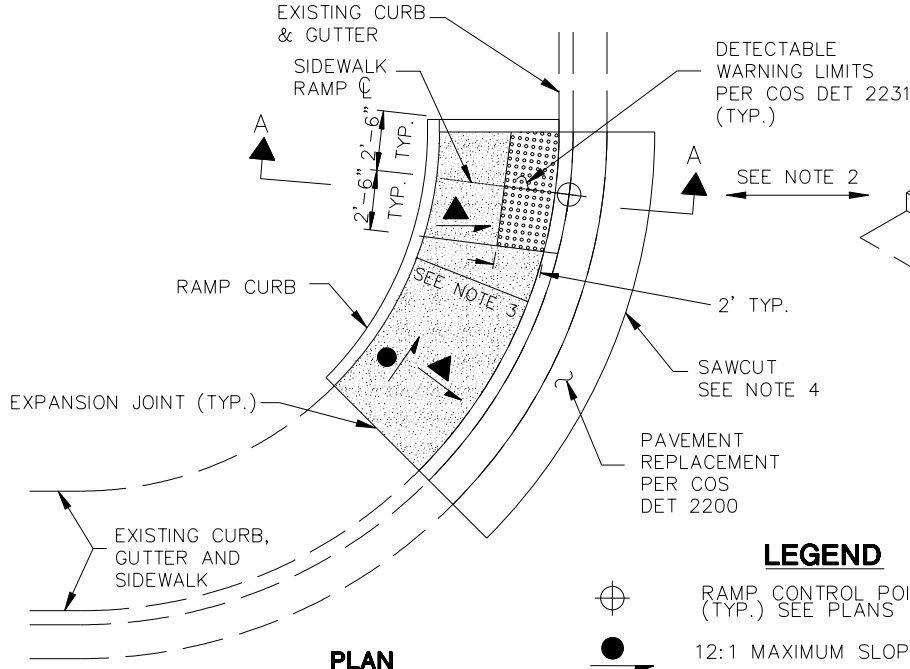

LEGEND

- RAMP CONTROL POINT (TYP.) SEE PLANS
- 12:1 MAXIMUM SLOPE, 15:1 DESIRED SLOPE
- 2% MAXIMUM SLOPE, 1.5% MINIMUM SLOPE
- 8" SIDEWALK RAMP PAYMENT LIMITS AND HEAVY ROUGH BROOM FINISH LIMITS

- NOTES:
1. ALL CONCRETE TO BE CLASS "B", MAG SECTION 725.
 2. ALL RAMPS AND DETECTABLE WARNING SHALL BE ALIGNED PERPENDICULAR TO THE CURB AT THE RAMP CONTROL POINT. CROSSWALKS SHALL BE ALIGNED PERPENDICULAR TO THE STREET CENTERLINE AS MUCH AS POSSIBLE.
 3. RAMP LANDING WIDTH SHALL BE 5' PREFERRED, OR ELSE SHALL MATCH EXISTING WIDTH WITH A 4' MINIMUM, AS MEASURED RADIALLY FROM BACK OF CURB TO FACE OF RAMP CURB.
 4. WHEN A CONCRETE APRON EXISTS THE SAWCUT MAY BE MADE IN THE APRON 2' FROM BACK OF EXISTING CURB.
 5. SEE PLANS FOR LOCATION OF SIDEWALK RAMP CENTERLINE.
 6. PROVIDE 10" MAXIMUM TO FACE OF ANY EXISTING PEDESTRIAN PUSH BUTTON. RAMP CURB AND LANDING MAY NEED TO BE EXTENDED AROUND POLE TO PROVIDE ACCESS TO PUSH BUTTON, OR MOVE BUTTON AS NEEDED.
 7. THIS SIDEWALK RAMP DETAIL IS FOR RETROFITTING ONLY AND IS NOT TO BE USED FOR NEW CONSTRUCTION.
 8. EACH RAMP RETROFIT REQUIRES A SITE SPECIFIC ASSESSMENT AND FIELD REVIEW BY THE DESIGN ENGINEER TO ENSURE A FUNCTIONAL DESIGN.

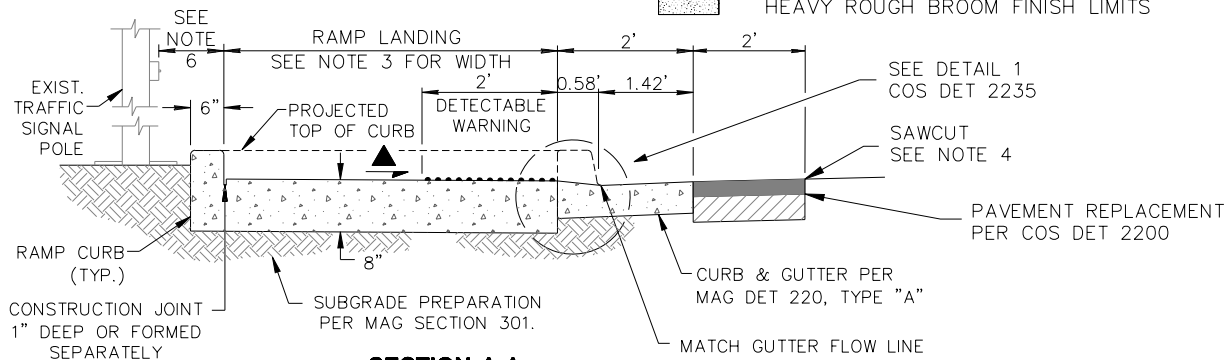

DETAIL NO. 2233-2	City of Scottsdale Standard Details	APPROVED BY: Scottsdale Standards & Specifications Committee	DIRECTIONAL SIDEWALK RAMP RETROFIT - TYPE B	DETAIL NO. 2233-2
-----------------------------	--	--	--	-----------------------------

REVISED 12/13/11

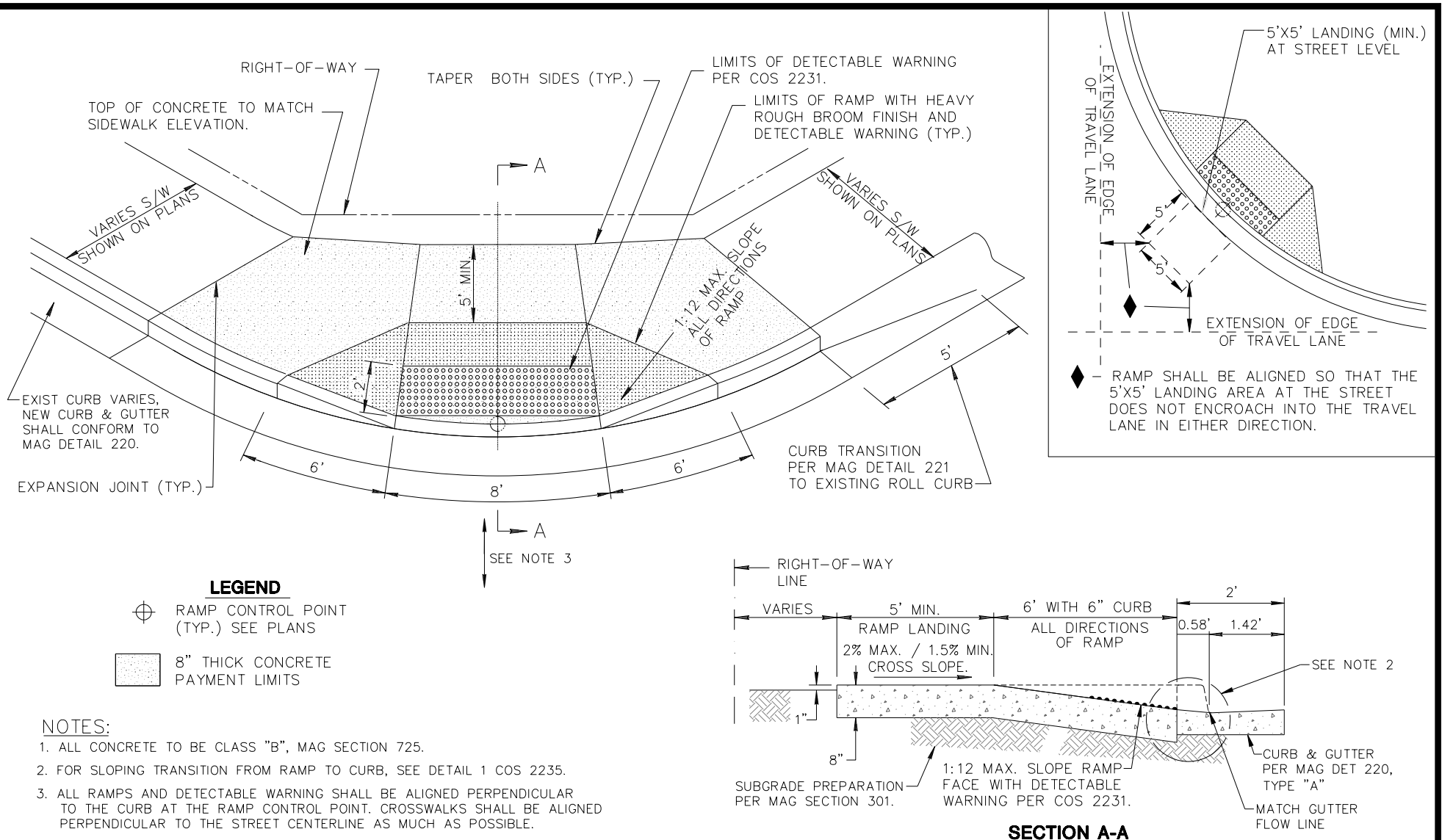

NOTES:

1. ALL CONCRETE TO BE CLASS "B", MAG SECTION 725.
2. FOR SLOPING TRANSITION FROM RAMP TO CURB, SEE DETAIL 1 COS 2235.
3. ALL RAMPS AND DETECTABLE WARNING SHALL BE ALIGNED PERPENDICULAR TO THE CURB AT THE RAMP CONTROL POINT. CROSSWALKS SHALL BE ALIGNED PERPENDICULAR TO THE STREET CENTERLINE AS MUCH AS POSSIBLE.

SECTION A-A

DETAIL NO.
2234

City of Scottsdale
Standard Details

APPROVED BY:
Scottsdale Standards & Specifications Committee

SHARED CURB SIDEWALK RAMP

DETAIL NO.
2234

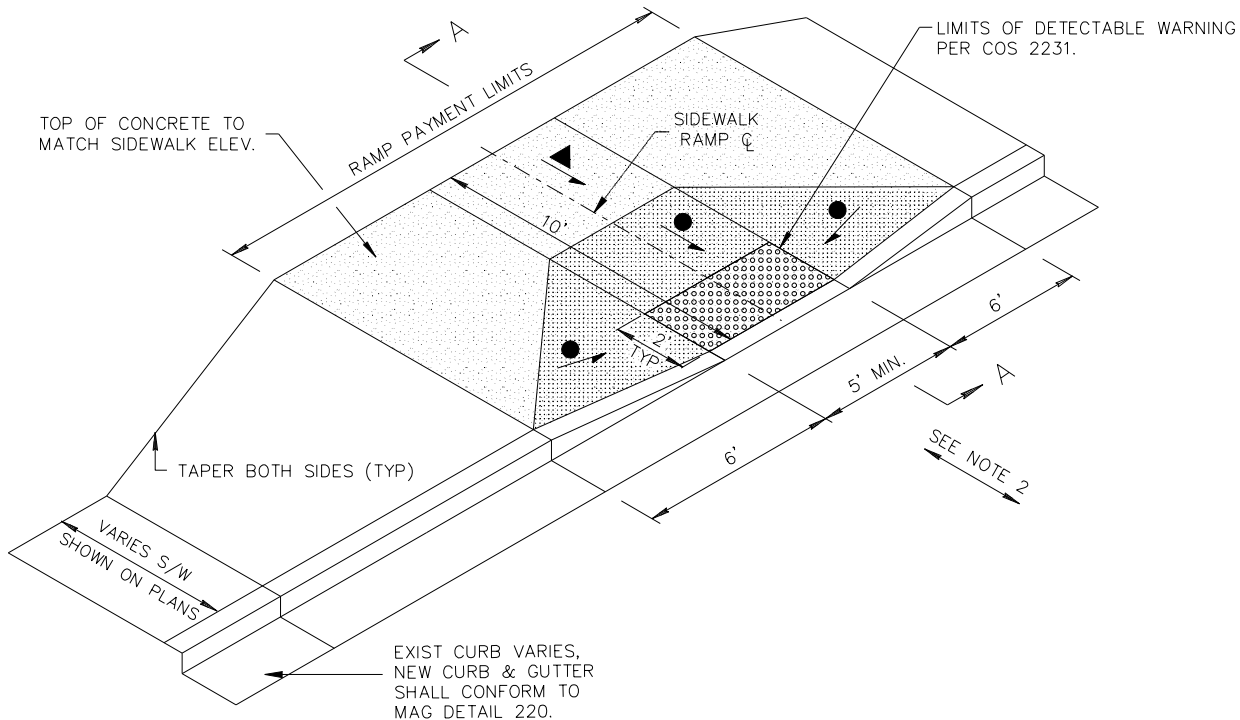

REVISED 9/22/11



NOTES:

1. ALL CONCRETE TO BE CLASS "B", MAG SECTION 725.
2. ALL RAMPS AND DETECTABLE WARNING SHALL BE ALIGNED PERPENDICULAR TO THE CURB. CROSSWALKS SHALL BE ALIGNED PERPENDICULAR TO THE STREET CENTERLINE AS MUCH AS POSSIBLE.
3. SEE PLANS FOR LOCATION OF SIDEWALK RAMP CENTERLINE.

LEGEND

-  12:1 MAXIMUM SLOPE, 15:1 DESIRED SLOPE
-  2% MAXIMUM SLOPE, 1.5% MINIMUM SLOPE
-  8" THICK CONCRETE PAYMENT LIMITS

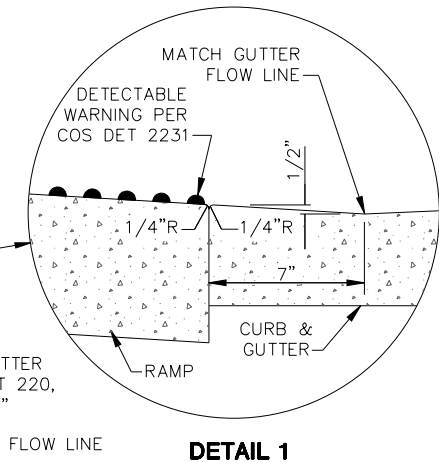
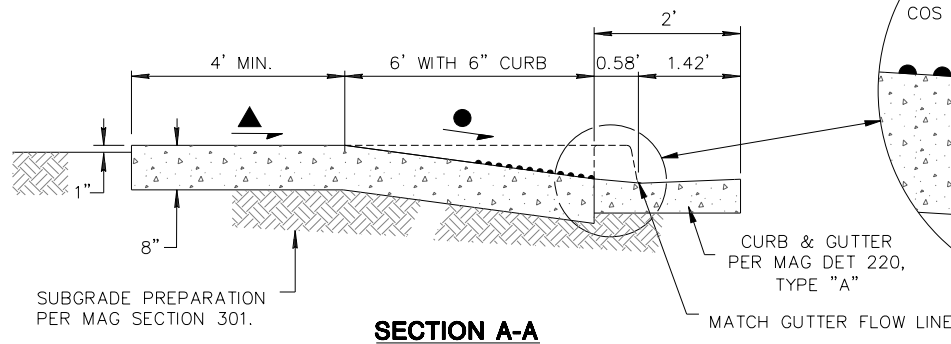

SECTION A-A

DETAIL 1

DETAIL NO.
2235-1

City of Scottsdale
Standard Details

APPROVED BY:
Scottsdale Standards &
Specifications Committee

MID-BLOCK SIDEWALK RAMP - TYPE A

DETAIL NO.
2235-1

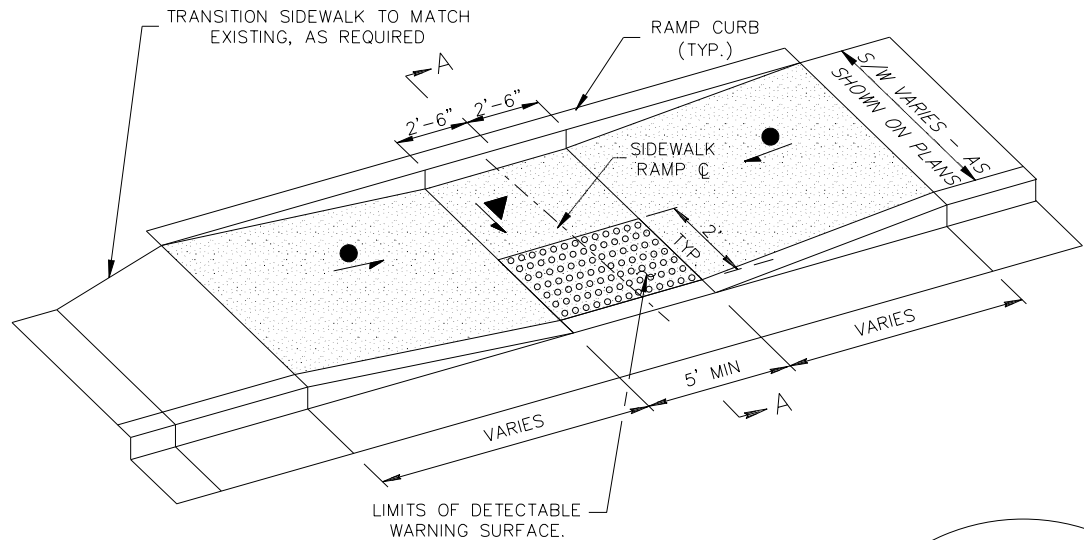

REVISED 12/13/11



NOTES:

1. ALL CONCRETE TO BE CLASS "B", MAG SECTION 725.
2. ALL RAMPS AND DETECTABLE WARNING SHALL BE ALIGNED PERPENDICULAR TO THE CURB. CROSSWALKS SHALL BE ALIGNED PERPENDICULAR TO THE STREET CENTERLINE AS MUCH AS POSSIBLE.
3. SEE PLANS FOR LOCATION OF SIDEWALK RAMP CENTERLINE.

LEGEND

-  12:1 MAXIMUM SLOPE,
15:1 DESIRED SLOPE
-  2% MAXIMUM SLOPE,
1.5% MINIMUM SLOPE
-  8" SIDEWALK RAMP PAYMENT
LIMITS AND HEAVY ROUGH
BROOM FINISH LIMITS

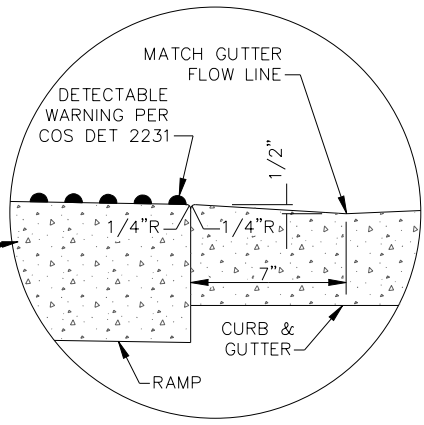
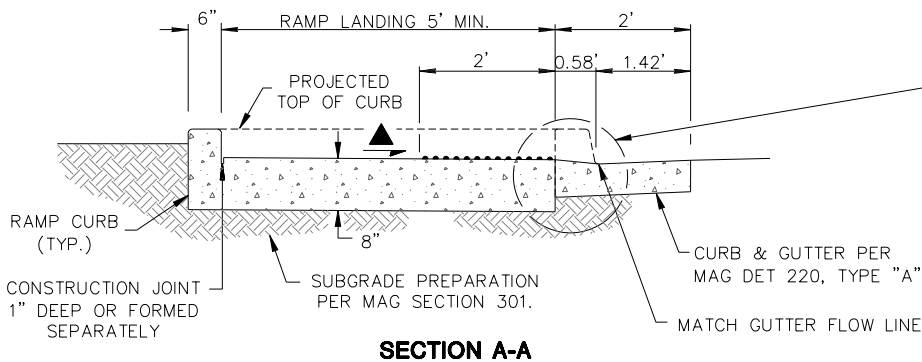

DETAIL 1

DETAIL NO.
2235-2

**City of Scottsdale
Standard Details**

APPROVED BY:
**Scottsdale Standards &
Specifications Committee**

MID-BLOCK SIDEWALK RAMP - TYPE B

DETAIL NO.
2235-2

NOTES:

1. 1/2" Expansion Joint, ASTM D-1751
Per MAG Sec. 729, and Elastomeric Sealant
Per COS Sec. 342.3.4.
2. Contraction Joints Per COS Supplemental
Specifications Sec. 342.
3. Materials And Construction Per COS
Supplemental Specifications Sec. 342.

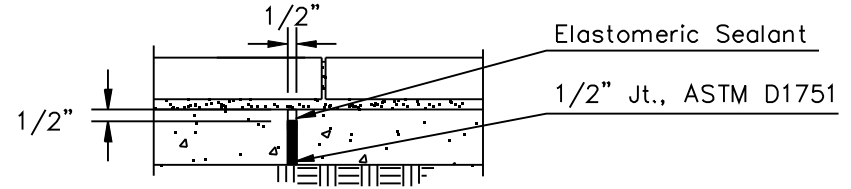

**Section A-A
Expansion or
Construction Joint**

Concrete Curb &
Gutter, Ribbon Curb,
Or As Otherwise
Indicated On Plans

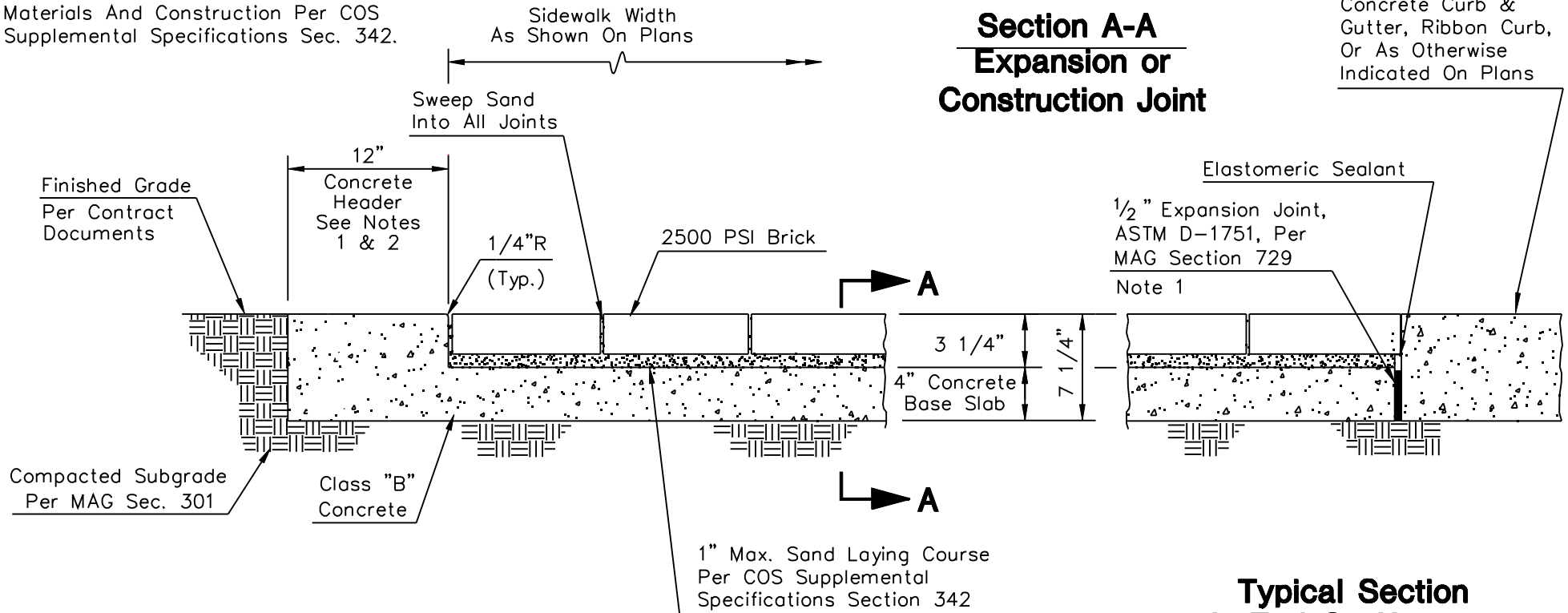

**Typical Half Section
(Against Earth)**

**Typical Section
At End Or Alternate
Half Section
(Against Concrete)**

DETAIL NO.

2237

**City of Scottsdale
Standard Details**

APPROVED BY:

**Scottsdale Standards &
Specifications Committee**

SIDEWALK PAVERS (NON-TRAFFIC BEARING)

DETAIL NO.

2237

REVISED 1/18/12

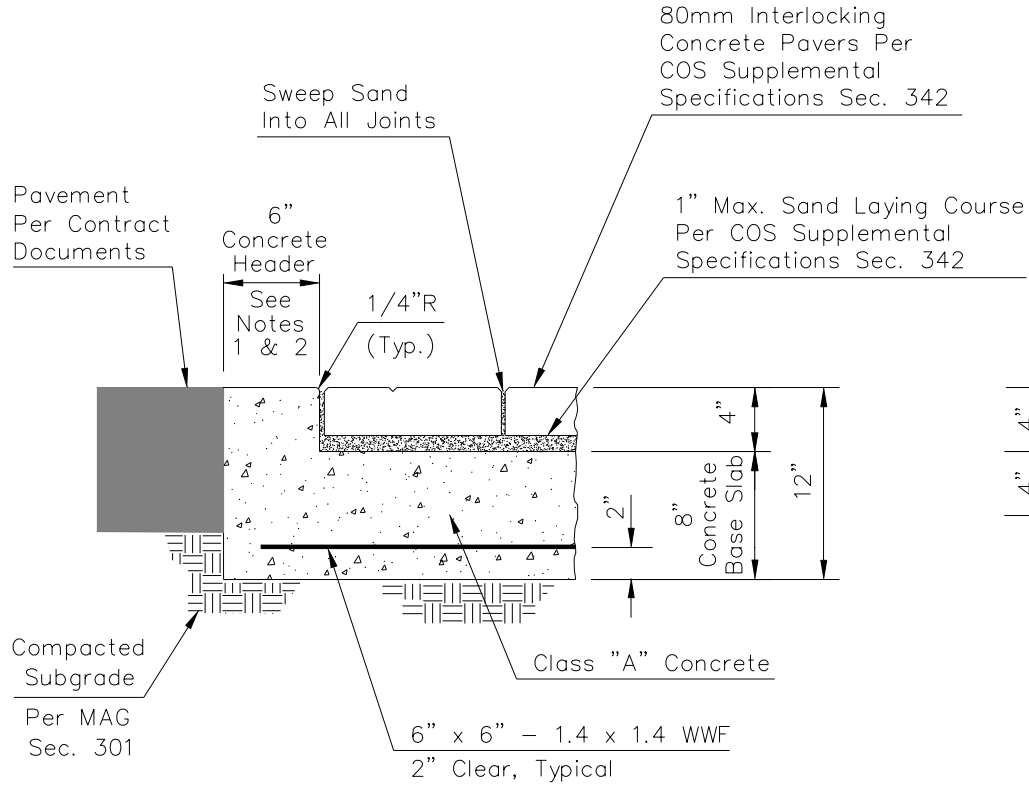

Type "B"
Flush Median

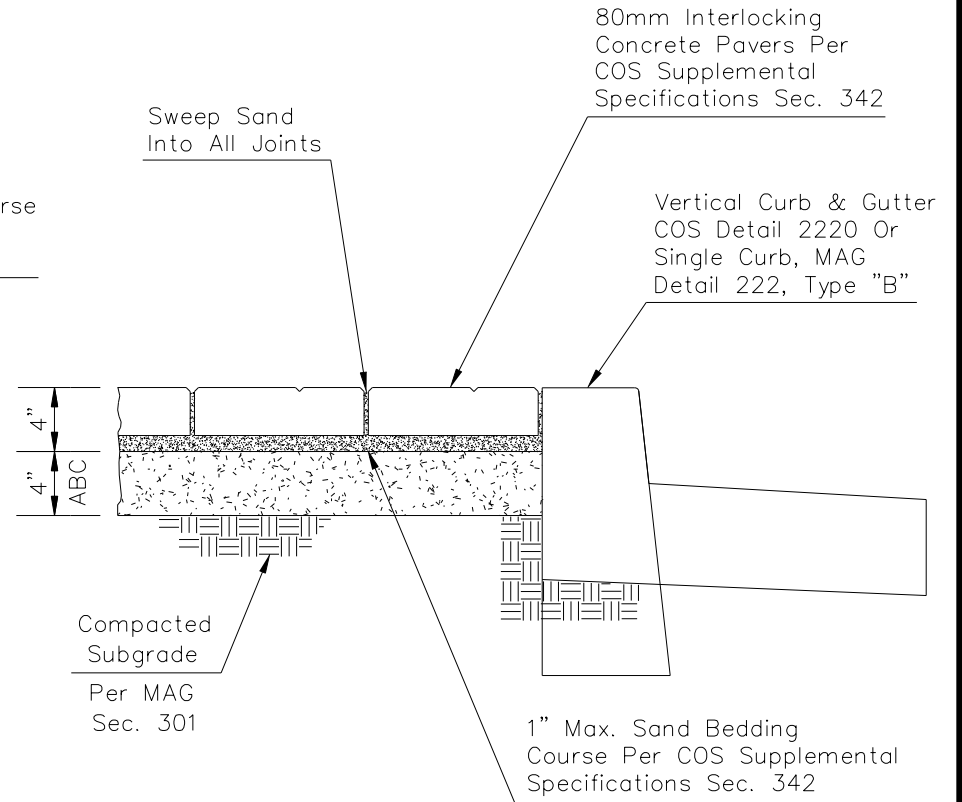

Type "A"
Raised Median

NOTES:

1. 1/2" Expansion Joint, ASTM D-1751 Per MAG Sec. 729, Every 50'.
2. Contraction Joints Per COS Supplemental Specifications Sec. 342, Every 10'.
3. Materials And Construction Per COS Supplemental Specifications Sec. 342.
4. Maximum allowable joint gap is 1/2".

DETAIL NO.
2239

City of Scottsdale
Standard Details

APPROVED BY:
Scottsdale Standards & Specifications Committee

MEDIAN CONCRETE PAVERS

DETAIL NO.
2239

REVISED 5/10/05

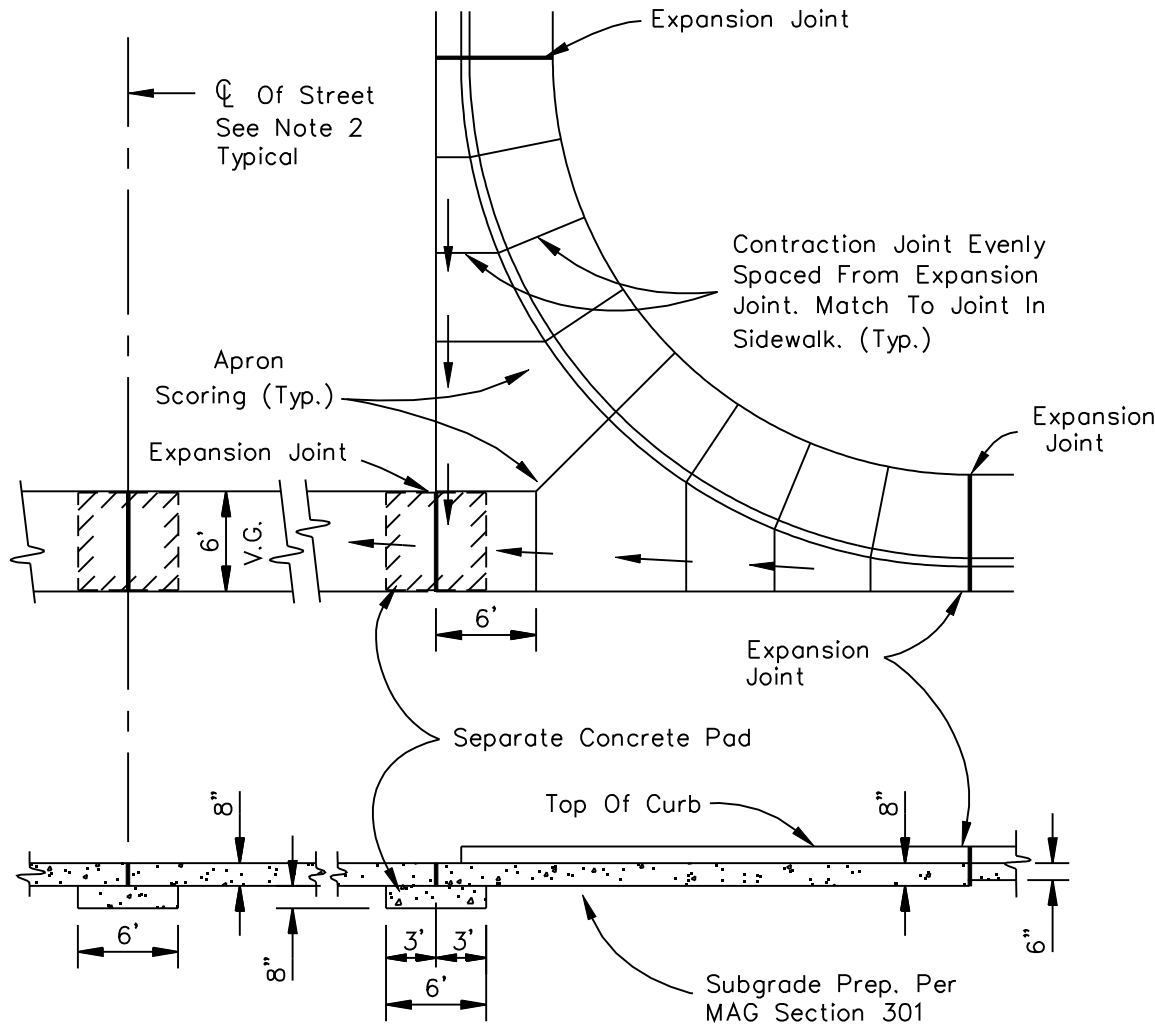

SECTION THRU APRON FLOW-LINE

NOTES

1. All Concrete To Be Class "A", MAG Section 725.
2. Use A Construction Joint Or Contraction Joint At The Cl Of Street. A Separate Concrete Pad Is Required With A Construction Joint.
3. 1/2" Expansion Joint, ASTM D-1751 Per MAG Section 729.
4. Return Curb and Sidewalk to be Monolithically Poured.

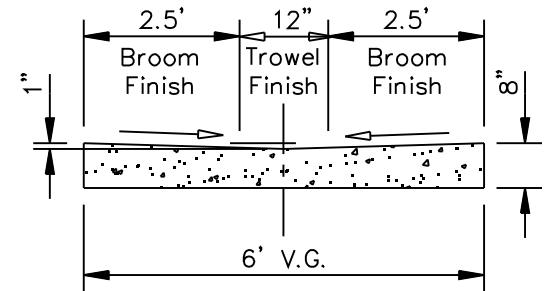

SECTION THRU VALLEY GUTTER

DETAIL NO.
2240

City of Scottsdale
Standard Details

APPROVED BY:
Scottsdale Standards &
Specifications Committee

6' VALLEY GUTTER & APRON

DETAIL NO.
2240

REVISED 5/10/05

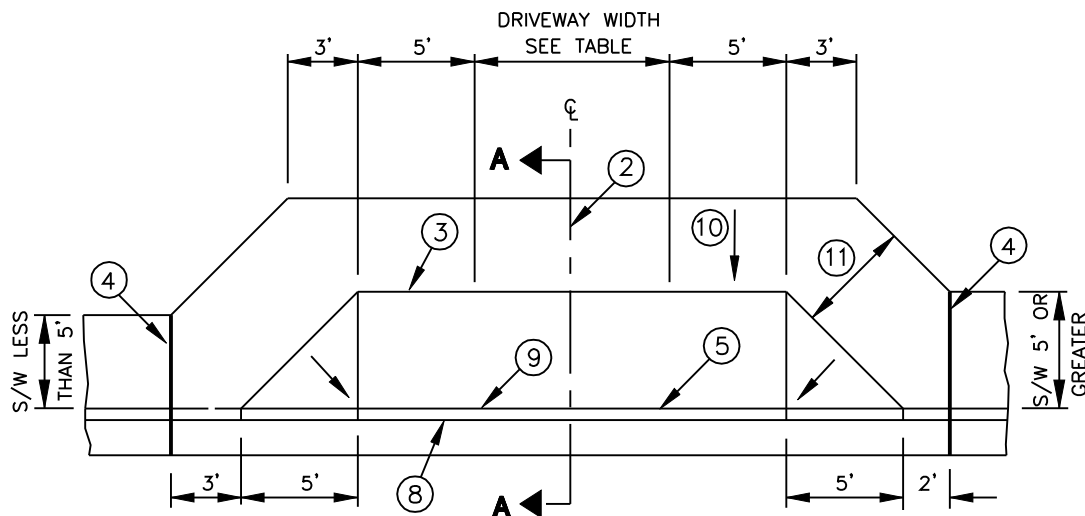

PLAN

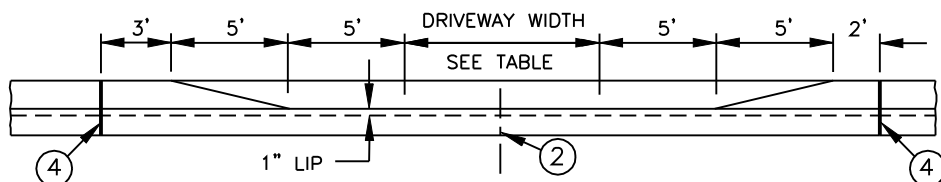

ELEVATION

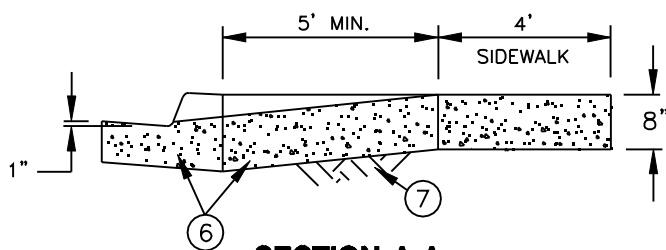

SECTION A-A

NOTES

- 1 DEPRESSED CURB SHALL BE PAID FOR AT THE UNIT PRICE BID FOR THE TYPE OF CURB USED AT THAT LOCATION.
- 2 CONTRACTION JOINT ON DRIVEWAY CENTERLINE.
- 3 BACK OF DRIVEWAY ENTRANCE – CONSTRUCTION JOINT OR SCORE MARK.
- 4 MASTIC EXPANSION JOINT THROUGH CURB AND GUTTER. EXPANSION JOINT FILLER SHALL BE 1/2" BITUMINOUS TYPE PREFORMED EXPANSION JOINT FILLER A.S.T.M. D-1751.
- 5 BACK OF CURB – CONSTRUCTION JOINT OR SCORE MARK.
- 6 CLASS 'B' CONCRETE, MAG SECTION 725.
- 7 SUBGRADE PREPARATION, MAG SECTION 301.
- 8 FLOW LINE OF GUTTER.
- 9 DEPRESSED CURB.
- 10 2% MAXIMUM CROSS SLOPE. 1.5% MINIMUM CROSS SLOPE
- 11 CONCRETE SIDEWALK PER MAG DETAIL 230, MODIFIED. THICKNESS = 8"

COMMERCIAL & INDUSTRIAL			
DRIVEWAY WIDTH	MIN.	MAX.	CLASS
COMMERCIAL ZONING	+ 16'	40'	B
INDUSTRIAL ZONING	+ 16'	40'	B
+ 24' MIN. FOR TWO WAY TRAFFIC			
RESIDENTIAL			
DRIVEWAY WIDTH	MIN.	MAX.	CLASS
MAJOR STREET	16'	30'	B
COLLECTOR STREET	*12'	30'	B
LOCAL STREET	12'	30'	B
* 16' DESIRABLE			

DETAIL NO.
2250

**City of Scottsdale
Standard Details**

APPROVED BY:
**Scottsdale Standards &
Specifications Committee**

DRIVEWAY ENTRANCES

DETAIL NO.
2250

REVISED 3/31/10

CONSTRUCTION NOTES

1. Sidewalk shall conform to MAG Std. Detail 230 and C.O.S. Sect. 340.
2. Curb as called for on plans.
3. Driveway entrances shall conform to COS Std. Detail 2250. Driveways shall be 3" of R-3/4" asphalt on 6" A.B.C. unless otherwise noted. See plans for driveway limits.
4. Valley gutter shall conform to COS Standard Detail 2240.
5. Sidewalk width, sidewalk ramp configuration and detectable warning surface as called for on plans.
6. Curb termination similar to MAG Std. Det 222.
7. When installing new driveways along an existing street, sawcut, remove & replace a minimum 2' wide strip of A.C. pavement per COS Standard Detail 2200.

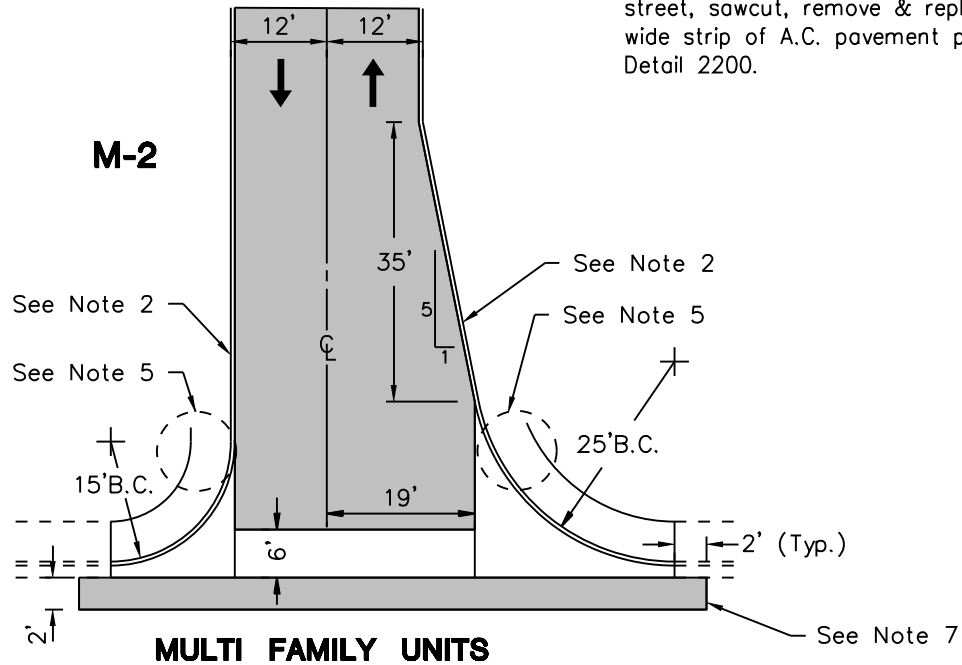
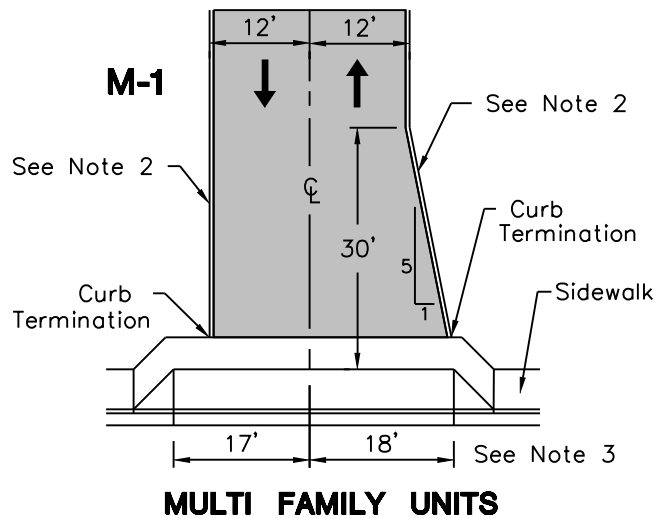
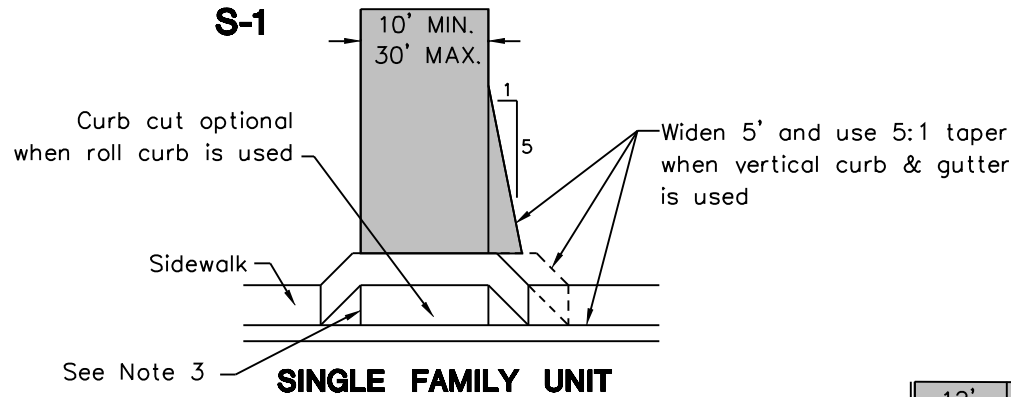

DETAIL NO.
2255

City of Scottsdale
Standard Details

APPROVED BY:
Scottsdale Standards & Specifications Committee

RESIDENTIAL DRIVEWAYS

DETAIL NO.
2255

REVISED 5/17/06

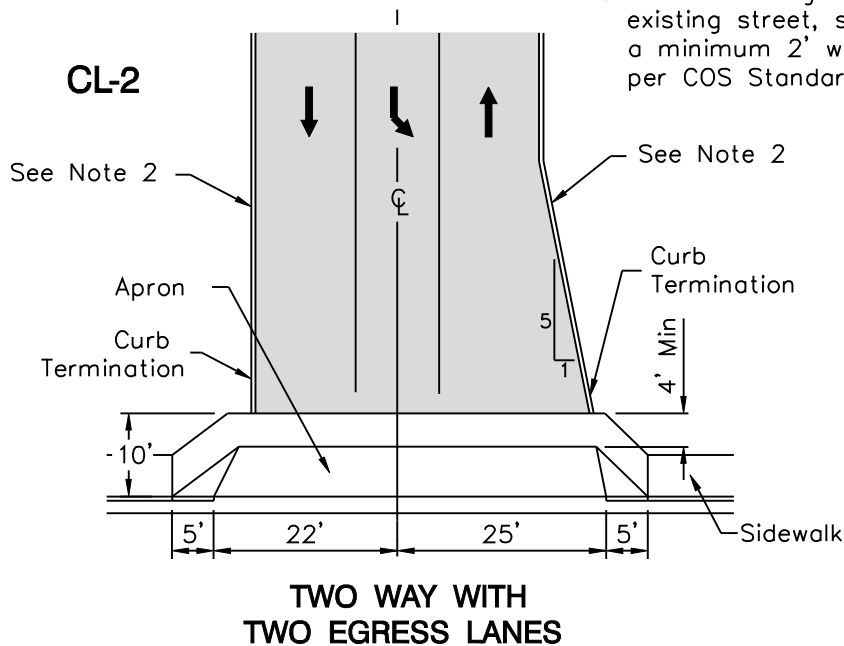
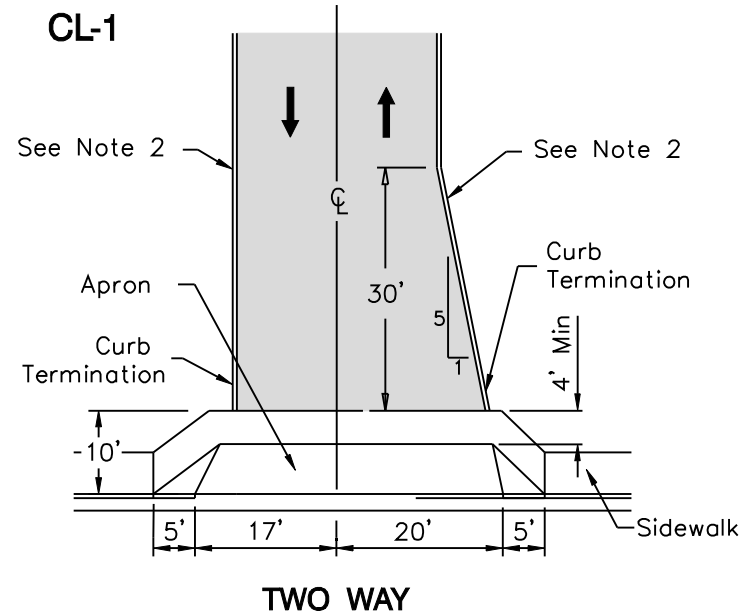
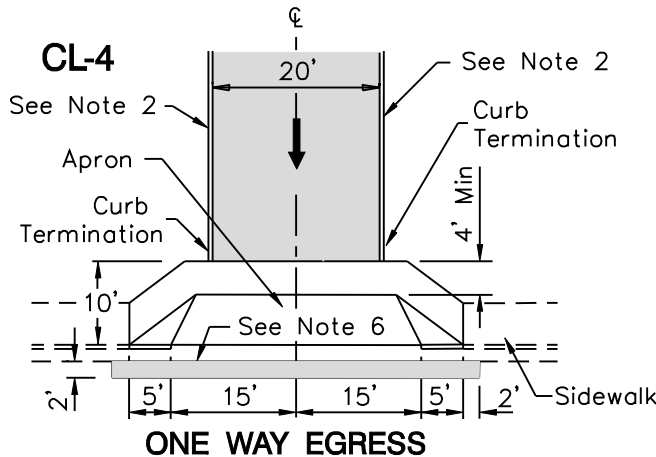
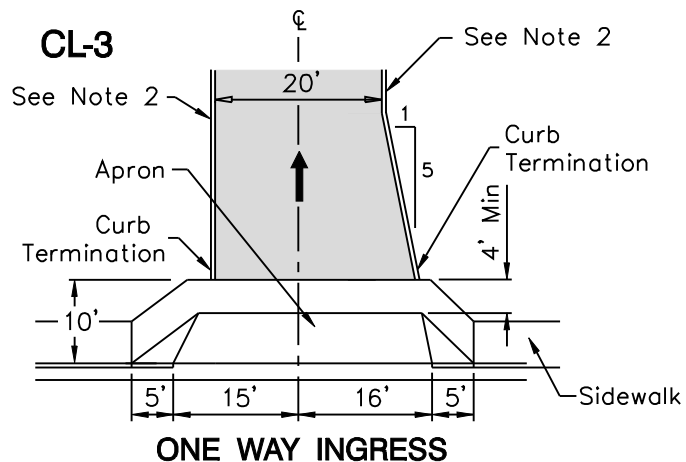

CONSTRUCTION NOTES

1. Sidewalk shall conform to MAG Standard Detail 230 and C.O.S. Sec. 340.
2. Curb as called for on plans.
3. Curb & Gutter shall conform to MAG Standard Detail 220. Single Curb shall conform to MAG Standard Detail 222.
4. Driveway Entrances shall conform to COS Standard Detail 2250 except for modifications as noted. Driveways shall be 2-1/2" A.C. A-19 on 6" A.B.C. unless otherwise noted. See plans for driveway limits.
5. Curb termination similar to MAG Std. Det. 222.
6. When installing new driveways along an existing street, sawcut, remove & replace a minimum 2' wide strip of A.C. pavement per COS Standard Detail 2200.

DETAIL NO.
2256

**City of Scottsdale
Standard Details**

APPROVED BY:
**Scottsdale Standards &
Specifications Committee**

COMMERCIAL/INDUSTRIAL DRIVEWAYS-TYPE CL

DETAIL NO.
2256

REVISED 3/31/10

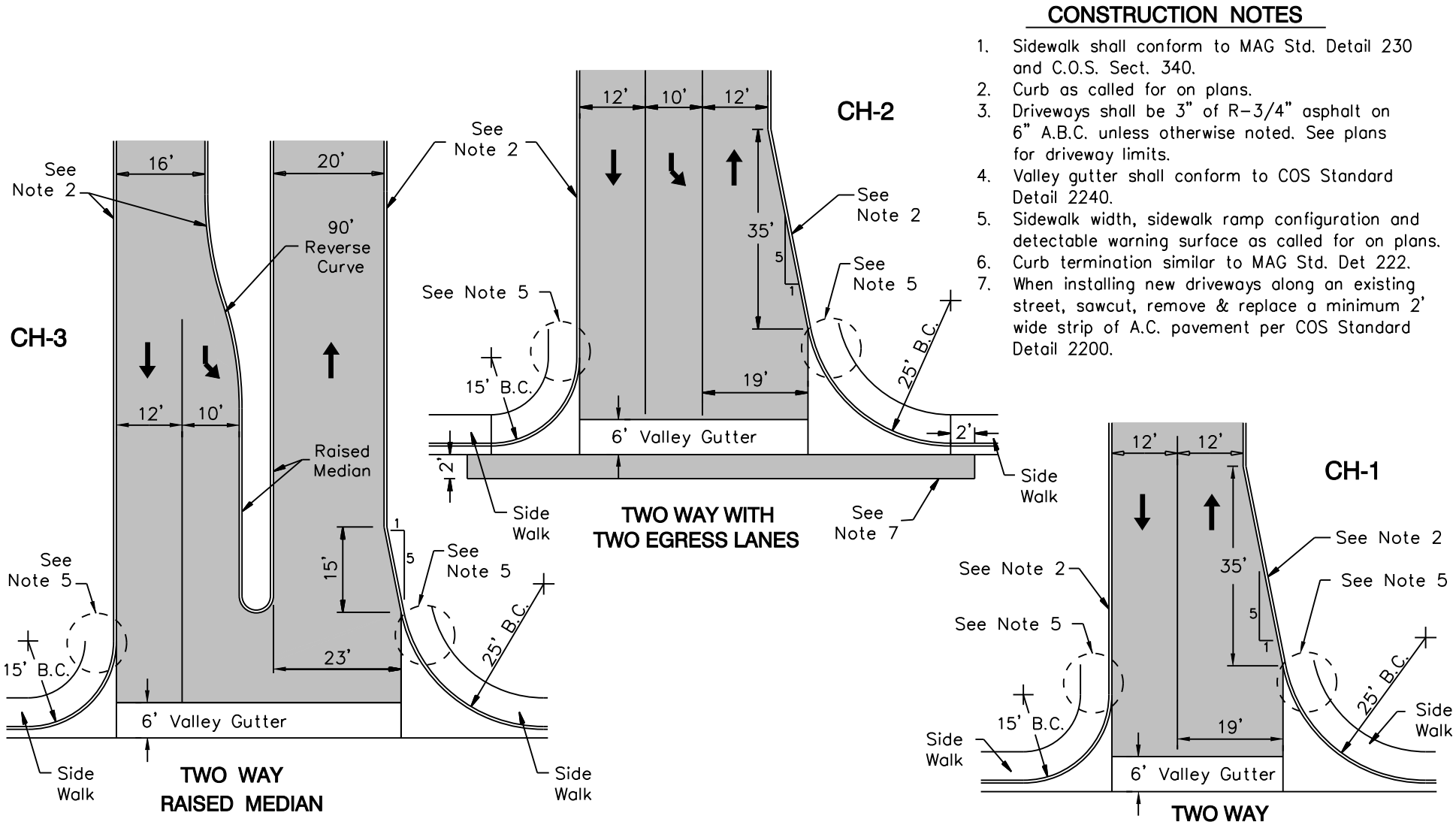

CONSTRUCTION NOTES

1. Sidewalk shall conform to MAG Std. Detail 230 and C.O.S. Sect. 340.
2. Curb as called for on plans.
3. Driveways shall be 3" of R-3/4" asphalt on 6" A.B.C. unless otherwise noted. See plans for driveway limits.
4. Valley gutter shall conform to COS Standard Detail 2240.
5. Sidewalk width, sidewalk ramp configuration and detectable warning surface as called for on plans.
6. Curb termination similar to MAG Std. Det 222.
7. When installing new driveways along an existing street, sawcut, remove & replace a minimum 2' wide strip of A.C. pavement per COS Standard Detail 2200.

DETAIL NO.
2257

**City of Scottsdale
Standard Details**

APPROVED BY:
**Scottsdale Standards &
Specifications Committee**

COMMERCIAL/INDUSTRIAL DRIVEWAYS-TYPE CH

DETAIL NO.
2257

REVISED 3/31/10

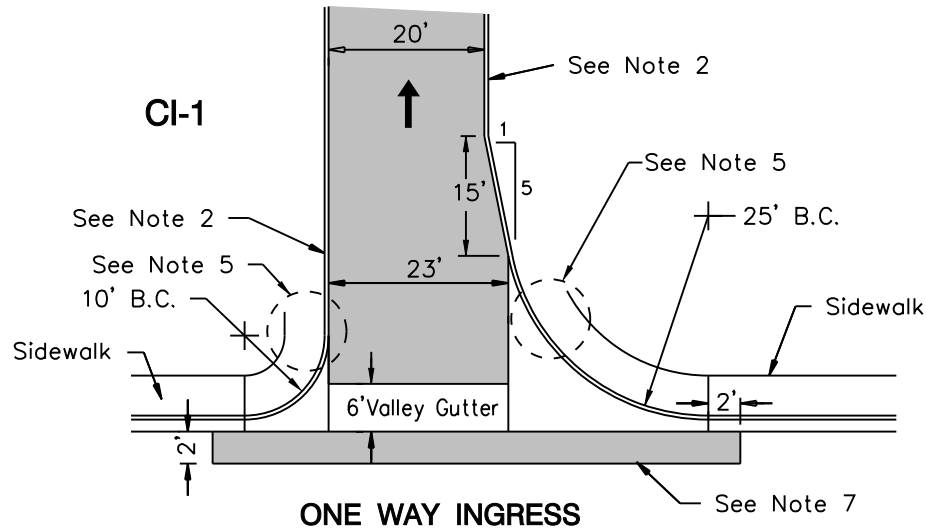

CONSTRUCTION NOTES

1. Sidewalk shall conform to MAG Std. Detail 230 and C.O.S. Sect. 340.
2. Curb as called for on plans.
3. Driveways shall be 3" of R-3/4" asphalt on 6" A.B.C. unless otherwise noted. See plans for driveway limits.
4. Valley gutter shall conform to COS Standard Detail 2240.
5. Sidewalk width, sidewalk ramp configuration and detectable warning surface as called for on plans.
6. Curb termination similar to MAG Std. Det 222.
7. When installing new driveways along an existing street, sawcut, remove & replace a minimum 2' wide strip of A.C. pavement per COS Standard Detail 2200.

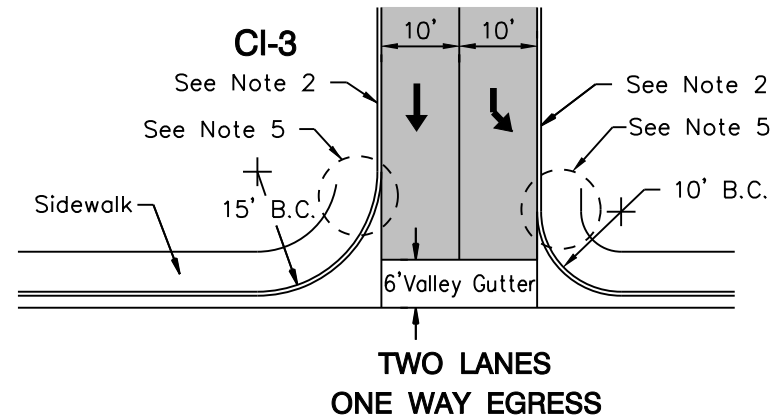
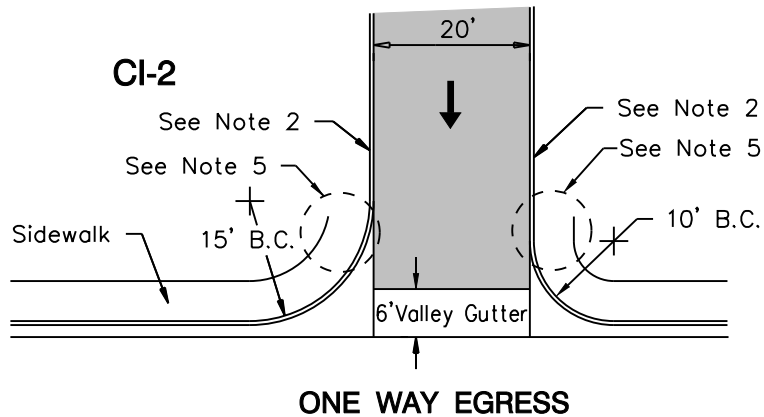

DETAIL NO.
2258

City of Scottsdale
Standard Details

APPROVED BY:
Scottsdale Standards & Specifications Committee

COMMERCIAL/INDUSTRIAL DRIVEWAYS-TYPE CI

DETAIL NO.
2258

REVISED 6/12/12

BENCH CONFIRM MFR & MODEL NO.
W/ C.O.S. TRANSPORTATION DIVISION
EXPANSION BOLT TO CONCRETE SLAB
PER MANUFACTURERS SPECIFICATION.
LOCATION SHALL CONFORM TO ADA
REQUIREMENTS. APPROVAL BY C.O.S.
REQUIRED.

1/2"x4" EXPANSION FELT
BOTH SIDES OF BOTTOM
PANELS (TYP OF 4).

4" CONC SLAB
ON 4" A.B.C.

TRASH RECEPT W/ LID -
CONFIRM LOCATION, MFR
& MODEL NO. W/ C.O.S.
TRANSPORTATION DIVISION.
(MIN. 32 GAL CAPACITY).
EXPANSION BOLT TO CONC.
SLAB PER MANUFACTURERS
SPECIFICATION.

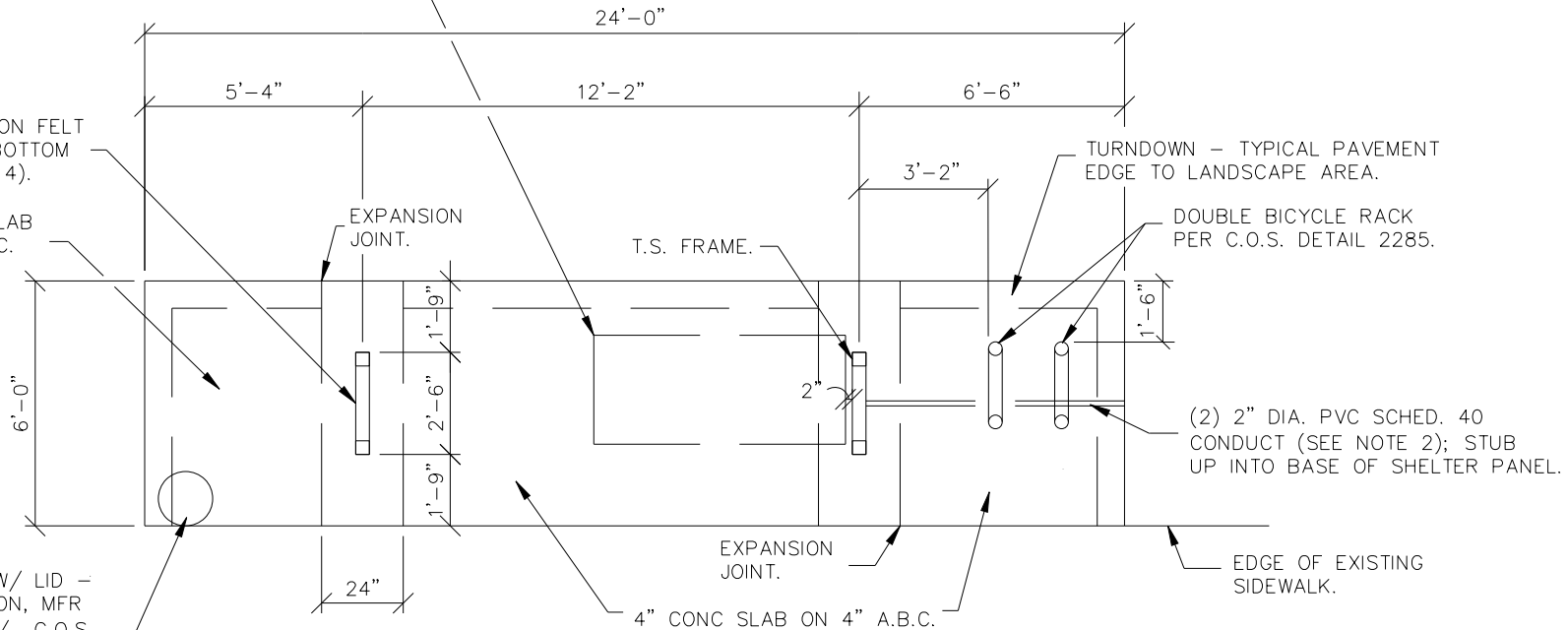

BUS SHELTER FOUNDATION PLAN

N.T.S.

NOTES:

1. SEE SPECIAL REQUIREMENTS (SEE SHEET 2265-6)
2. DEVELOPER OR DEVELOPER'S CONTRACTOR TO DETERMINE SOURCE OF FEED FOR ELECTRICAL SUPPLY, USE 2" SCHEDULE 40 PVC CONDUIT TO EXTEND FROM THE UPRIGHT TO THE SERVICE SOURCE WITH MIN. 3' COVER. IF NO ELECTRICAL SUPPLY EXISTS, STUB CONDUIT 3' BEYOND SHELTER PAD AND CAP BOTH ENDS. CONTACT CITY STAFF TO COORDINATE DIRECTION OF STUB OUT.

DETAIL NO.
2265-1

**City of Scottsdale
Standard Details**

APPROVED BY:
**Scottsdale Standards &
Specifications Committee**

BUS SHELTER

DETAIL NO.
2265-1

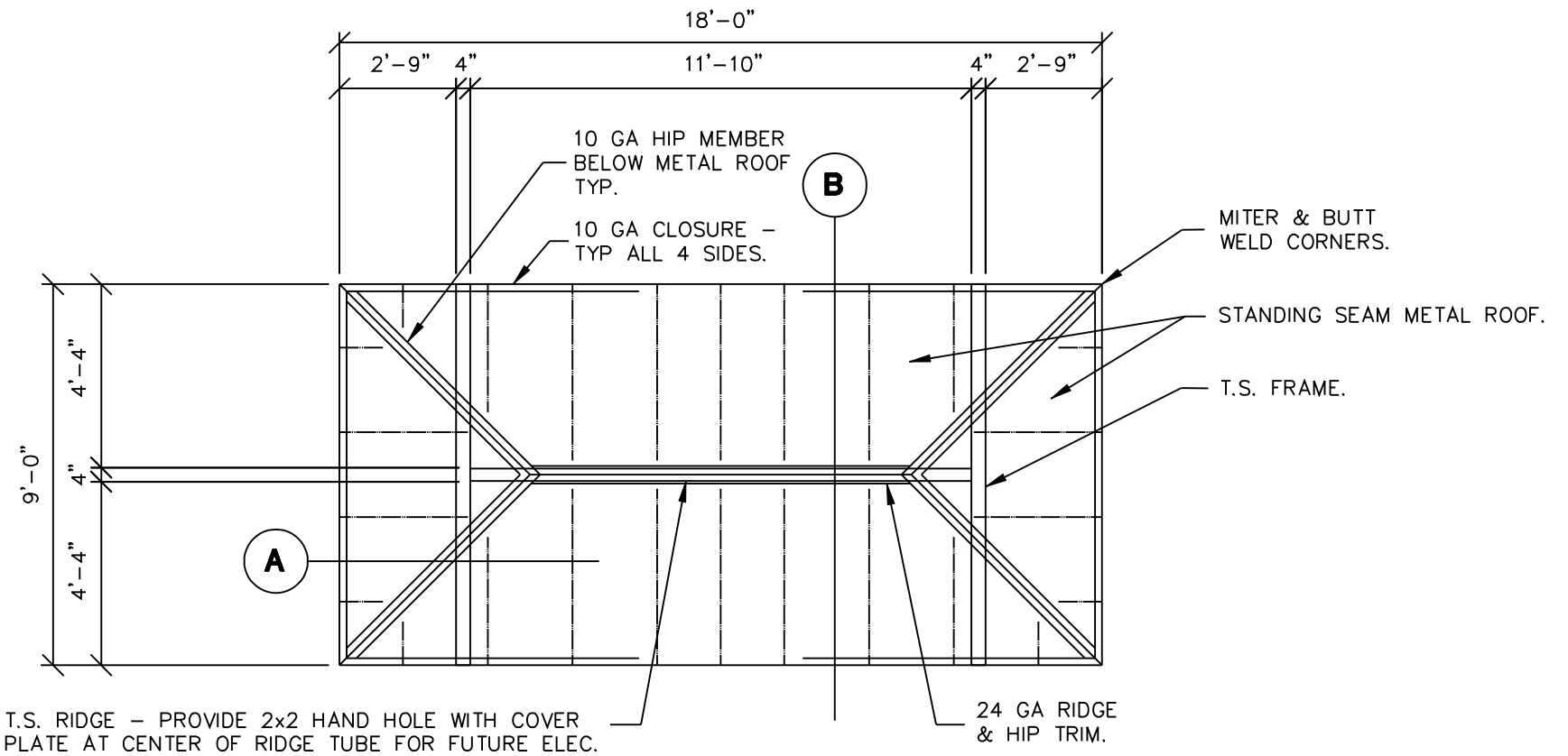

BUS SHELTER FRAMING PLAN

NTS.

DETAIL NO.
2265-2

City of Scottsdale
Standard Details

APPROVED BY:
Scottsdale Standards & Specifications Committee

BUS SHELTER

DETAIL NO.
2265-2

REVISED 5/17/06

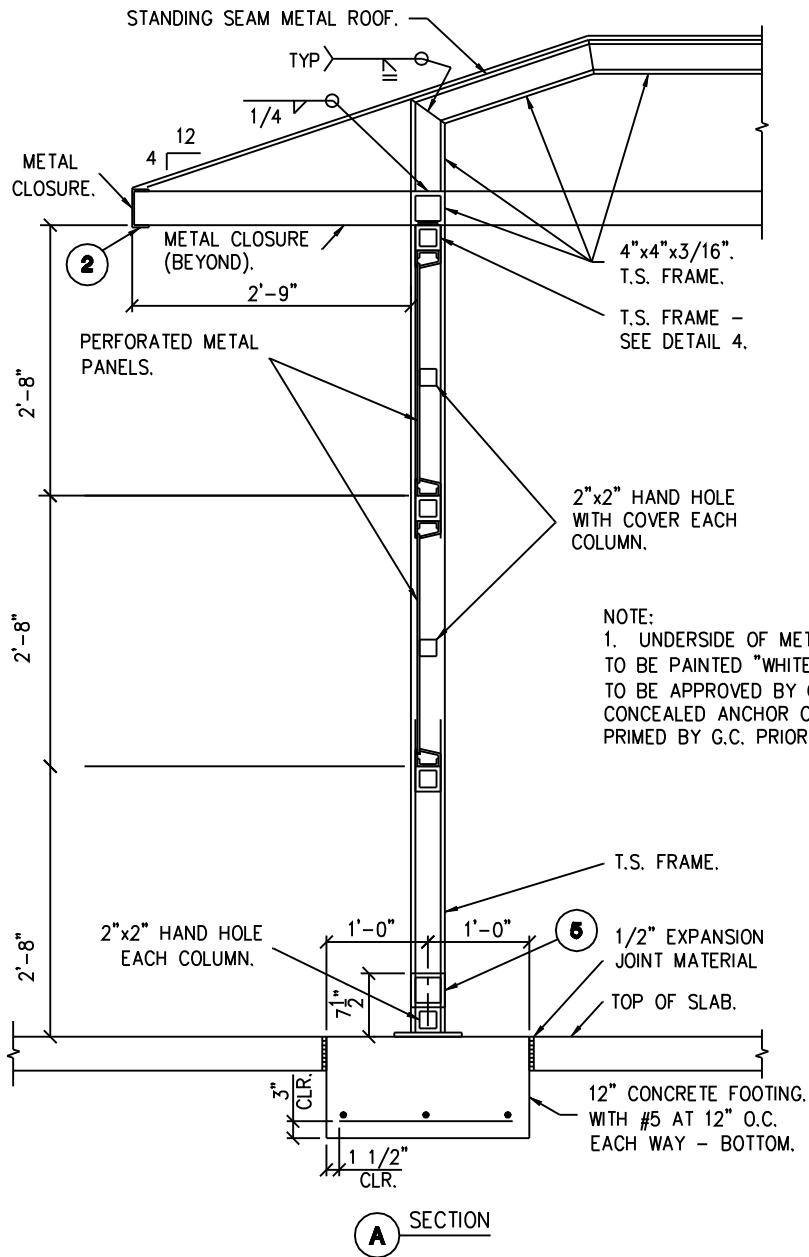

A SECTION

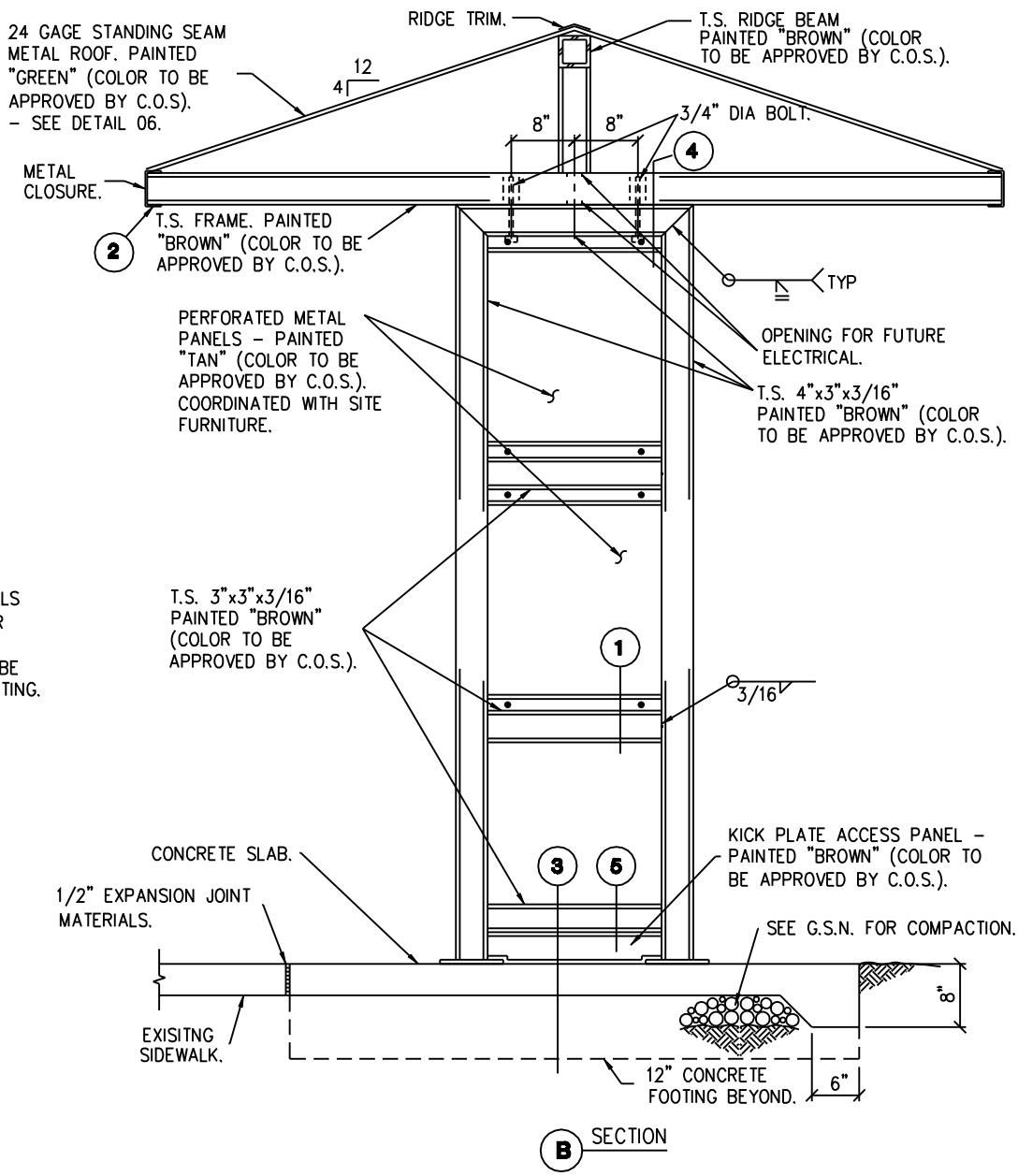

B SECTION

NOTE:
 1. UNDERSIDE OF METAL PANELS TO BE PAINTED "WHITE" (COLOR TO BE APPROVED BY C.O.S.)
 CONCEALED ANCHOR CUPS TO BE PRIMED BY G.C. PRIOR TO PAINTING.

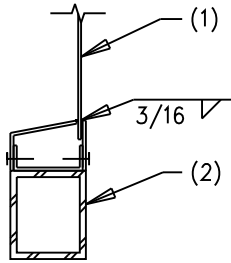

- NOTES:**
1. PREFORATED PANEL. COORDINATE WITH SITE FURNITURE.
 2. STEEL TUBE.

01 PANEL TO FRAME CONNECTION
03-520 NO SCALE

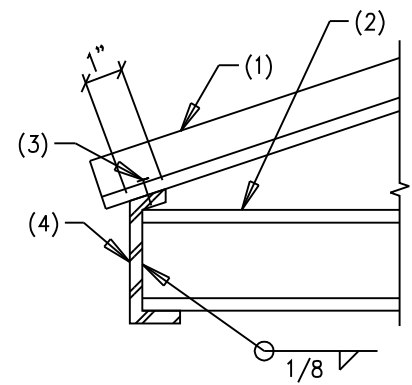

- NOTES:**
1. STANDING SEAM METAL DECK.
 2. STEEL TUBE.
 3. BLACK OXIDE SCREW FASTENER AT 6" O.C. (MIN 4" AT EACH END).
 4. CLOSURE PANEL.

02 TYPICAL CLOSURE
03-520 NO SCALE

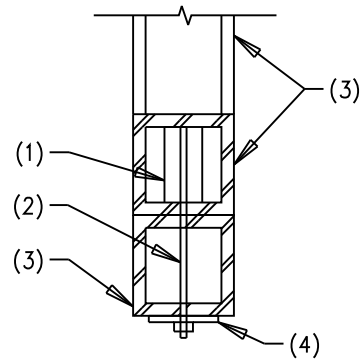

- NOTES:**
1. 3/4" THREAD INSERT.
 2. 3/4" DIA. BOLT.
 3. STEEL TUBE.
 4. 3"x2"x1/4" PLATE WASHER.

04 CONNECTION AT ROOF STRUCTURE
03-520 NO SCALE

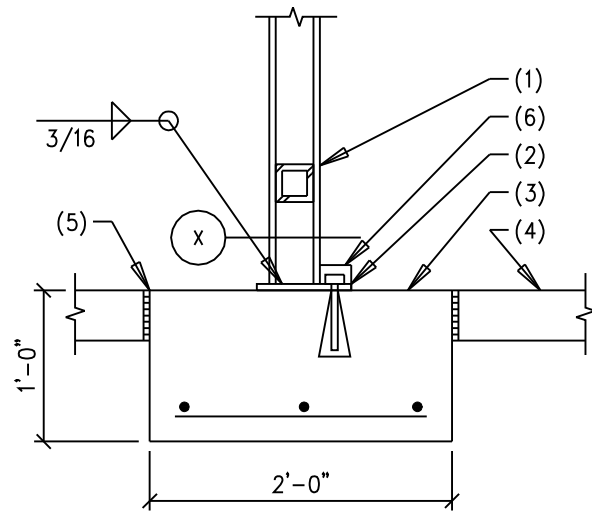

- NOTES:**
1. STEEL TUBE.
 2. BASE PLATE 1/2"x6 1/4"x7 1/2" WITH 2 - 3/4" DIA. x 7" EXPANSION BOLT.
 3. CONCRETE FOOTING.
 4. CONCRETE SLAB.
 5. EXPANSION JOINT MATERIAL.
 6. BOLT COVER SEE DETAIL 08.

03 FOOTING AT T.S. FRAME
03-520 NO SCALE

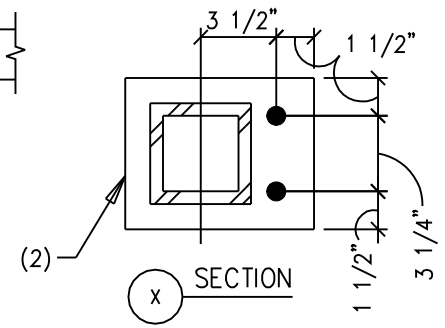

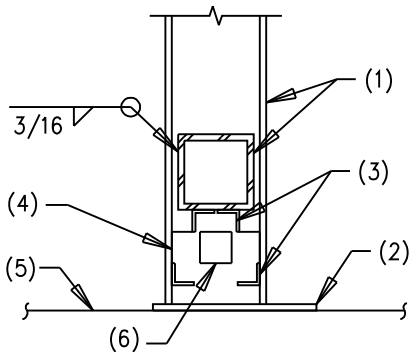

NOTES:

1. STEEL TUBE.
2. BASE PLATE - SEE DETAIL 03.
3. 1"x1" ANGLE.
4. 16 GAGE PANEL.
5. TOP OF SLAB.
6. 2"x2" HAND HOLE AT TUBE FRAME BEYOND - SEE SECTION A FOR LOCATIONS.

05 KICK PLATE ACCESS PANEL

03-520 NO SCALE

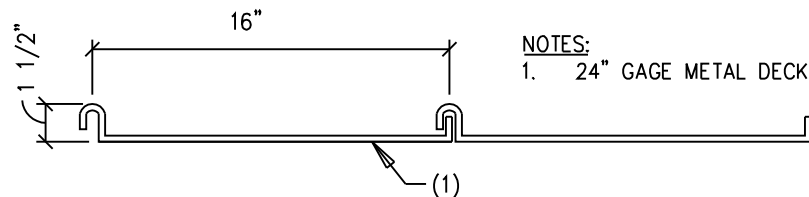

NOTES:

1. 24" GAGE METAL DECK.

06 STANDING SEAM METAL DECK

03-520 NO SCALE

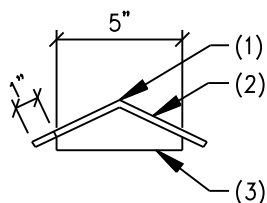

NOTES:

1. $S_y = .058$
 $I_x = .0219$
 $F_y = 50$ KSI.
2. 10 GAGE HIP MEMBER BELOW METAL ROOF - TYP.
3. 22 GAGE METAL SNAP COVER PLATE - CREASE MIDDLE; TRIM EDGES TO FIT END CONDITIONS.

07 METAL COVER PLATE

03-520 NO SCALE

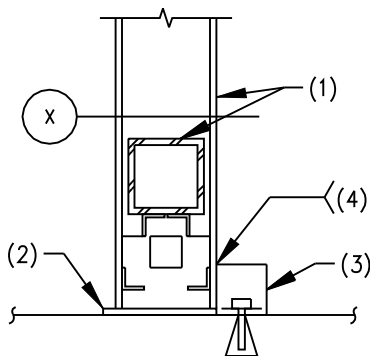

NOTES:

1. STEEL TUBE.
2. BASE PLATE.
3. 16 GAGE METAL COVER.
4. TACK WELD.

NOTE:

FOR INFORMATION SHOWN BUT NOT NOTED SEE DET 05.

08 BOLT COVER

03-520 NO SCALE

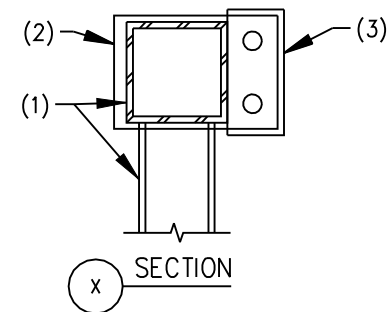

SECTION

GENERAL STRUCTURAL NOTES

BUILDING CODE:

2003 EDITION OF THE UNIFORM BUILDING CODE, WITH CITY OF SCOTTSDALE AMENDMENTS.

LOADS:

LATERAL:

WIND LOAD = 90 MPH WIND SPEED, EXPOSURE C. SEISMIC ZONE 2B (Z = 0.075)

FOUNDATIONS:

COMPACT SUB GRADE AND BASE MATERIAL TO 95% OF THE ASTM D698 MAXIMUM DRY DENSITY.

CONCRETE:

MINIMUM 28 DAY STRENGTH 3,000 PSI

ALL CAST-IN-PLACE CONCRETE CONSTRUCTION SHALL CONFORM TO THE LATEST EDITION OF THE ACI. FOR CONCRETE WITHOUT PLASTICIZER, MAXIMUM SLUMP 4 1/2" AT POINT OF PLACEMENT U.N.O. IF PLASTICIZER IS USED, A HIGHER FINAL SLUMP MAY BE ALLOWED UPON STRUCTURAL ENGINEER'S APPROVAL.

REINFORCING:

ALL REINFORCING PER CRSI SPECIFICATIONS AND HANDBOOK. ASTM A615 (Fy = 60 KSI/GRADE 60) DEFORMED BARS FOR ALL BARS.

ALL REINFORCING SHALL BE CHAIRED TO ENSURE PROPER CLEARANCES. SUPPORT OF FOUNDATION REINFORCING MUST PROVIDE ISOLATION FROM MOISTURE CORROSION BY USE OF A PLASTIC OR CONCRETE CHAIR. DUCT-TAPE COVERED REINFORCING IS NOT AN ACCEPTABLE CHAIR.

ALL DIMENSIONS REFERENCED IN DRAWINGS AS "CLEAR" SHALL BE FROM FACE OF STRUCTURE TO EDGE OF REINFORCING, AND SHALL NOT BE LESS THAN STATED, NOR GREATER THAN "CLEAR" DIMENSION PLUS 3/8". ALL OTHERS SHALL BE PLUS OR MINUS 1/4" TYPICAL UNLESS NOTED OTHERWISE.

STRUCTURAL STEEL:

ALL CONSTRUCTION PER LATEST AISC HANDBOOK. ALL TUBE STEEL SHALL BE ASTM A500(Fy=46 KSI). ALL MISCELLANEOUS STEEL UNLESS NOTED OTHERWISE SHALL BE ASTM A36 (Fy = 36 KSI).

UNLESS NOTED OTHERWISE, ALL WELDS PER LATEST EDITION OF THE AWS STANDARDS. ALL WELDING SHALL BE PERFORMED BY WELDERS HOLDING VALID CERTIFICATES AND HAVING CURRENT EXPERIENCE IN THE TYPE OF WELD SHOWN ON THE DRAWINGS OR NOTES. CERTIFICATES SHALL BE THOSE ISSUED BY AN ACCEPTED

STRUCTURAL STEEL: CONT'D

TESTING AGENCY. ALL WELDING DONE BY E70 SERIES LOW HYDROGEN RODS UNLESS NOTED OTHERWISE. FOR GRADE 60 REINFORCING BARS, USE E90 SERIES. THESE DRAWINGS DO NOT DISTINGUISH BETWEEN SHOP AND FIELD WELDS; THE CONTRACTOR MAY SHOP WELD OR FIELD WELD AT THEIR DISCRETION. SHOP WELDS AND FIELD WELDS SHALL BE SHOWN ON THE SHOP DRAWINGS SUBMITTED FOR REVIEW.

STEEL DECKING:

ALL STANDING SEAM DECK SHALL CARRY A U.L. 90 UPLIFT RATING. INSTALLATION SHALL CONFORM TO STANDARDS SET FORTH IN THE ARCHITECTURAL SHEET METAL MANUAL PUBLISHED BY SMACNA.

WELDERS EXPERIENCED IN LIGHT GAGE STEEL DECK WORK SHALL PERFORM ALL WELDING. DECK WELDING MAY BE ACHIEVED WITH E60 SERIES NON LOW HYDROGEN RODS OR E70 SERIES LOW HYDROGEN RODS.

SCREWS WHERE INDICATED SHALL BE #12-24 TRAXX PER ICBO 3056 OR APPROVED EQUIVALENT.

SHOP DRAWINGS:

SHOP DRAWINGS SHALL BE SUBMITTED FOR ALL STRUCTURAL ITEMS.

THE CONTRACTOR SHALL REVIEW ALL SHOP DRAWINGS PRIOR TO SUBMITTAL. ITEMS NOT IN ACCORDANCE WITH CONTRACT DOCUMENTS SHALL BE FLAGGED UPON CONTRACTOR'S REVIEW.

MANUFACTURER OR FABRICATOR SHALL CLOUD ANY CHANGES, SUBSTITUTIONS, OR DEVIATIONS FROM CONTRACT DOCUMENTS. ANY OF THE FOREMENTIONED WHICH ARE NOT CLOUDED OR FLAGGED BY SUBMITTING PARTIES, SHALL NOT BE CONSIDERED APPROVED AFTER ENGINEER'S REVIEW, UNLESS NOTED ACCORDINGLY.

THE ENGINEER HAS THE RIGHT TO APPROVE OR DISAPPROVE ANY CHANGES TO CONTRACT DOCUMENTS AT ANYTIME BEFORE OR AFTER SHOP DRAWING REVIEW.

THE SHOP DRAWINGS DO NOT REPLACE THE CONTRACT DOCUMENTS. ITEMS OMITTED OR SHOWN INCORRECTLY AND ARE NOT FLAGGED BY THE STRUCTURAL ENGINEER OR ARCHITECT SHALL NOT BE CONSIDERED CHANGES TO CONTRACT DOCUMENTS. IT IS THE CONTRACTOR'S RESPONSIBILITY TO ENSURE ITEMS ARE CONSTRUCTED TO CONTRACT DOCUMENTS. THE ADEQUACY OF ENGINEERING DESIGNS AND LAYOUT PERFORMED BY OTHERS RESTS WITH THE DESIGNING OR SUBMITTING AUTHORITY.

SHOP DRAWINGS: CONT'D

REVIEWING IS INTENDED ONLY AS AN AID TO THE CONTRACTOR IN OBTAINING CORRECT SHOP DRAWINGS. RESPONSIBILITY FOR CORRECTNESS SHALL REST WITH THE CONTRACTOR.

SPECIAL REQUIREMENTS

1. AN ARTIST-DESIGNED SHELTER MAY BE SUBSTITUTED FOR STANDARD SHELTER BY APPROVAL OF THE CITY OF SCOTTSDALE TRANSIT SECTION. HOWEVER, IT MUST INCORPORATE ALL THE FUNCTIONAL ELEMENTS INCLUDED IN THE STANDARD SHELTER. SEE TRANSIT & DESIGN REVIEW STAFF FOR DETAILS.

2. STANDARD BUS STOP SIGN LOCATION, NEW OR RELOCATED SIGNS SHALL BE APPROVED BY THE TRAFFIC/TRANSIT STAFF.

3. ADDITIONAL REQUIREMENTS MAY INCLUDE:

- A) LEANING RAIL.
- B) LED REAL TIME BUS INFORMATION SIGN.
- C) BUS ROUTE/TRAFFIC INFORMATION KIOSKS.

D) PEDESTRIAN RAILING AROUND THE BACK OF SHELTER ADJACENT TO STEEP SLOPES OR DROP-OFFS.

4. CITY OF SCOTTSDALE TRANSIT BUS SHELTERS SHALL BE PROVIDED WITH A GROUNDING SYSTEM THAT MAY CONSIST OF ONE OF THE FOLLOWING METHODS:

A) 25 FEET OF #4 STANDARD COPPER (UNINSULATED) INSTALLED IN THE BASE OF ONE OF THE UPRIGHT FOUNDATIONS. THE GROUNDING CONDUCTOR WILL EXTEND OUT OF THE POURED CONCRETE FOUNDATION WITH A LENGTH NOT TO EXCEED 3 FEET. THE GROUNDING CONDUCTOR WILL BE WRAPPED IN A CLOCKWISE ROTATION, ONE WRAP, AROUND ON THE THE UPRIGHT ANCHOR BOLTS. A FLAT FENDER WASHER WILL BE INSTALLED ON TOP OF THE CONDUCTOR WITH THE ANCHOR BOLT NUT ON TOP OF THE FLAT WASHER AND SECURED.

B) A SECOND METHOD WILL CONSIST OF A 5/8"x 8'-0" GROUND ROD DRIVEN IN THE ELECTRICAL PULLBOX ADJACENT TO THE BUS SHELTER. A GROUND ROD TERMINAL NUT (ACORN NUT) WILL BE INSTALLED ON TOP OF THE GROUND ROD SECURING A #8 AWG BARE SOLID COPPER WIRE. THE GROUND WIRE WILL BE INSTALLED FROM THE JUNCTION BOX, UNBROKEN AND UNSPLICED, TO THE BUS SHELTER UPRIGHT WHERE IT WILL BE TERMINATED. A SET-SCREW TERMINAL LUG WILL BE FASTENED TO THE STRUCTURE UPRIGHT UNDER THE BOTTOM KICKPANEL. THE AREA UNDER THE TERMINAL LUG WILL BE CLEANED OF ALL RUST, SCALE AND PAINT. THE #8 BARE BOND CONDUCTOR WILL BE TERMINATED IN THE SET-SCREW TERMINAL LUG.

BOTH GROUNDING METHODS WILL BE DONE IN ACCORDANCE WITH ARTICLE 250 OF NATIONAL ELECTRICAL CODE.

DETAIL NO.	City of Scottsdale Standard Details	APPROVED BY: Scottsdale Standards & Specifications Committee	BUS SHELTER	DETAIL NO. 2265-6
------------	--	--	--------------------	-----------------------------

ABBREVIATIONS

NOTE: ABBREVIATIONS MAY OR MAY NOT HAVE PERIODS, BUT SHALL BE READ AS SAME.

A.B. _____ ANCHOR BOLT
 A.B.C. _____ AGGREGATE BASE COURSE
 ACI _____ AMERICAN CONCRETE INSTITUTE
 A/C _____ AIR CONDITIONER
 A.F.F. _____ ABOVE FINISHED FLOOR
 AISC _____ AMERICAN INSTITUTE OF STEEL
 CONSTRUCTION
 AISI _____ AMERICAN IRON AND STEEL
 INSTITUTE
 AITC _____ AMERICAN INSTITUTE OF TIMBER
 CONSTRUCTION
 ALT. _____ ALTERNATE
 ANSI _____ AMERICAN NATIONAL STANDARDS
 INSTITUTE
 APA _____ AMERICAN PLYWOOD ASSOCIATION
 ARCH'L _____ ARCHITECTURAL
 ASTM _____ AMERICAN SOCIETY FOR TESTING
 AND MATERIALS
 AWS _____ AMERICAN WELDING SOCIETY
 @ _____ AT (MEASUREMENT)
 BM _____ BEAM
 B.F.F. _____ BELOW FINISHED FLOOR
 BLK _____ BLOCK
 B.O.B. _____ BOTTOM OF BEAM
 B.O.D. _____ BOTTOM OF DECK
 B.O.F. _____ BOTTOM OF FOOTING
 BRG _____ BEARING
 C _____ CAMBER
 C.C. _____ CENTERLINE TO CENTERLINE
 C.G. _____ CENTER OF GRAVITY
 C.I.P. _____ CAST IN PLACE
 C.L. _____ CENTERLINE
 C.L.B. _____ CENTERLINE OF BEAM
 C.L.C. _____ CENTERLINE OF COLUMN
 C.L.F. _____ CENTERLINE OF FOOTING
 C.L.W. _____ CENTERLINE OF WALL
 CLR _____ CLEAR
 CONC _____ CONCRETE
 CONC C.J. _____ CONCRETE CONTROL JOINT
 CONC S.J. _____ CONCRETE SAWCUT JOINT
 C.M.U. _____ CONCRETE MASONRY UNIT
 CONN _____ CONNECTION
 CONT _____ CONTINUOUS
 C.O.S. _____ CITY OF SCOTTSDALE
 CRSI _____ CONCRETE REINFORCING STEEL
 INSTITUTE
 DL _____ DEAD LOAD
 ø OR DIA _____ DIAMETER

DN _____ DOWN
 DWG(S) _____ DRAWING(S)
 E.C. _____ END TO CENTERLINE
 E.E. _____ END TO END
 E.O.S. _____ EDGE OF SLAB
 EQ _____ EQUAL
 EQUIP _____ EQUIPMENT
 EXP. BOLT (E.B.) _____ EXPANSION BOLT
 EXP. JT (E.J.) _____ EXPANSION JOINT
 E.W. _____ EACH WAY
 F.F. _____ FINISHED FLOOR
 F.O.M. _____ FACE OF MEMBER
 F.O.S. _____ FACE OF STEEL
 F.O.W. _____ FACE OF WALL
 GA _____ GAGE (UNIT OF MEASUREMENT)
 GALV _____ GALVANIZED
 G.S.N. _____ GENERAL STRUCTURAL NOTES
 GLB (GLULAM) _____ GLUED-LAMINATED BEAM
 HORIZ _____ HORIZONTAL REINFORCING
 IBC _____ INTERNATIONAL BUILDING CODE
 ICBO _____ INTERNATIONAL CONFERENCE OF
 BUILDING OFFICIALS
 I.F.W. _____ INSIDE FACE OF WALL
 I.O.D. _____ INTERPRETATION OF DRAWINGS
 K(KIP) _____ 1000 POUNDS
 KLF _____ KIPS PER LINEAR FOOT
 LBS (#) _____ POUNDS
 LGS _____ LIGHT GAGE STEEL
 LGSEA _____ LIGHT GAGE STEEL ENGINEERS
 ASSOCIATION
 L.O.D. _____ LOCATION OF DETAILS
 LL _____ LIVE LOAD
 LLH _____ LONG LEG HORIZONTAL
 LLV _____ LONG LEG VERTICAL
 MAS _____ MASONRY
 MAS C.J. _____ MASONRY CONTROL JOINT
 MAX _____ MAXIMUM
 MBMA _____ METAL BUILDING MANUFACTURERS
 ASSOCIATION
 MECH'L _____ MECHANICAL
 MFR('S) _____ MANUFACTURER('S)
 MIN _____ MINIMUM
 N/A _____ NOT APPLICABLE
 N.T.S. _____ NOT TO SCALE
 O.C. _____ ON CENTER
 O.F.W. _____ OUTSIDE FACE OF WALL
 OPP _____ OPPOSITE
 OSHA _____ OCCUPATIONAL SAFETY AND
 HEALTH ADMINISTRATION

PCI _____ PRECAST/PRESTRESSED CONCRETE
 INSTITUTE
 P.C. _____ PRECAST CONCRETE
 PLF _____ POUNDS PER LINEAR FOOT
 ± _____ PLUS OR MINUS
 PREFAB _____ PREFABRICATED
 PSF _____ POUNDS PER SQUARE FOOT
 PSI _____ POUNDS PER SQUARE INCH
 PTI _____ POST-TENSIONING INSTITUTE
 REINF _____ REINFORCING
 SDI _____ STEEL DECK INSTITUTE
 SLH _____ SHORT LEG HORIZONTAL
 SLV _____ SHORT LEG VERTICAL
 SJI _____ STEEL JOIST INSTITUTE
 SIM _____ SIMILAR
 SQ. _____ SQUARE
 SSMA _____ STEEL STUD MANUFACTURERS
 ASSOCIATION
 STD _____ STANDARD
 STL _____ STEEL
 TL _____ TOTAL LOAD
 T.O.B. _____ TOP OF BEAM
 T.O.C.T. _____ TOP OF CONCRETE TOPPING
 T.O.D. _____ TOP OF DECK
 T.O.F. _____ TOP OF FOOTING
 T.O.L. _____ TOP OF LEDGER
 T.O.M. _____ TOP OF MASONRY
 T.O.P. _____ TOP OF PLATE
 T.O.P.C. _____ TOP OF PRECAST CONCRETE
 T.O.S. _____ TOP OF STEEL
 T.O.W. _____ TOP OF WALL
 TPI _____ TRUSS PLATE INSTITUTE
 TYP _____ TYPICAL
 T&G _____ TONGUE AND GROOVE
 UBC _____ UNIFORM BUILDING CODE
 U.N.O. _____ UNLESS NOTED OTHERWISE
 VERT _____ VERTICAL REINFORCING
 WCLA _____ WEST COAST LUMBER ASSOCIATION
 WCLIB _____ WEST COAST LUMBER INSPECTION
 BUREAU
 W.W.F. _____ WELDED WIRE FABRIC
 WWPA _____ WESTERN WOOD PRODUCTS
 ASSOCIATION
 W/ _____ WITH
 W/C _____ WATER TO CEMENT RATIO
 W/O _____ WITHOUT

DETAIL NO.

**2265-7 City of Scottsdale
 Standard Details**

APPROVED BY:

**Scottsdale Standards &
 Specifications Committee**

BUS SHELTER

DETAIL NO.

2265-7

REVISED 5/17/06

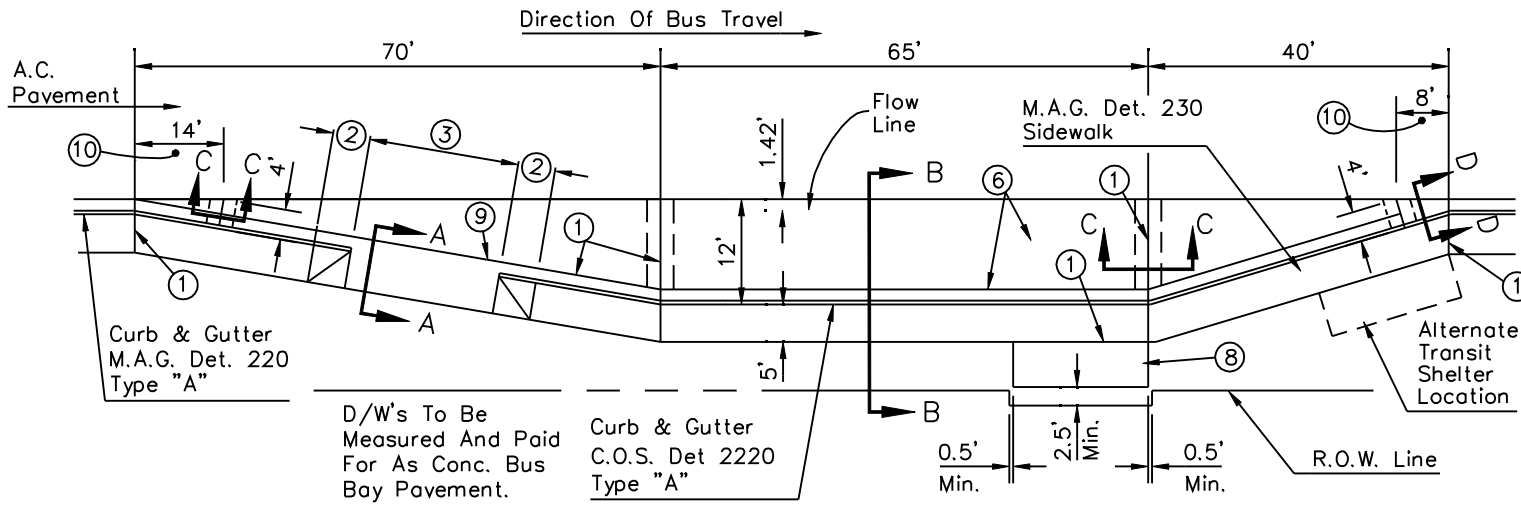

PLAN VIEW

- ① 1/2" BITUMINOUS PREFORMED EXPANSION JOINT FILLER, A.S.T.M. D-1751 PER MAG SEC. 729, INSTALL PER COS SEC. 340.3.
- ② TRANSITION CURB FACE FROM 6" TO 0" HEIGHT IN 5'
- ③ D/W WIDTHS & LOCATIONS VARY, SEE PLANS. MAINTAIN 10' MIN. CLEARANCE BETWEEN DRIVEWAYS AND SHELTER PAD. WHEN DRIVEWAY WIDTH EXCEEDS 22', PROVIDE A CONTRACTION JOINT ON D/W C.
- ④ SUBGRADE PREPARATION PER MAG SECTION 301.
- ⑤ CONCRETE PAD TO BE POURED SEPARATELY FROM CONCRETE BUS BAY PAVEMENT.
- ⑥ CONTRACTION JOINTS IN THE BUS BAY PAVEMENT SHALL MATCH THOSE IN THE CURB.
- ⑦ CONCRETE SHALL BE CLASS "A" PER MAG SECTION 725
- ⑧ TRANSIT SHELTER PAD, PER COS STD DETAIL 2265.
- ⑨ NEW CONCRETE D/W TO BE POURED WITH BUS BAY PAVEMENT.
- ⑩ CURB & GUTTER TO BUS BAY PAVEMENT TRANSITION.

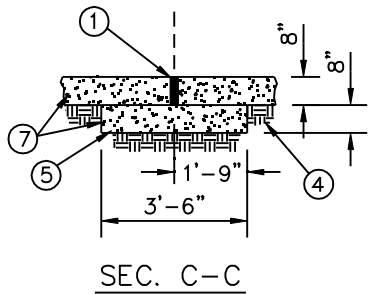

SEC. C-C

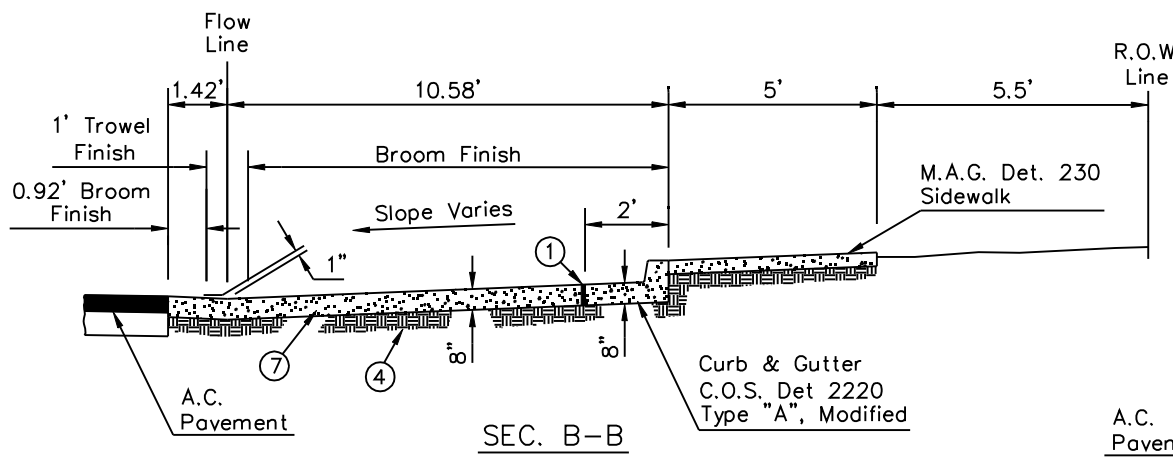

SEC. B-B

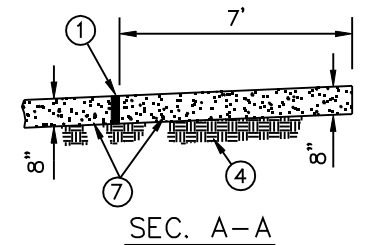

SEC. A-A

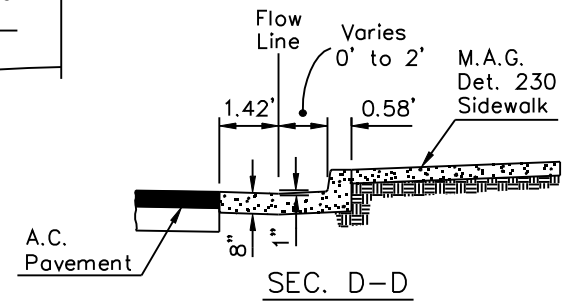

SEC. D-D

DETAIL NO. **2266-1** City of Scottsdale Standard Details

APPROVED BY: **Scottsdale Standards & Specifications Committee**

CLOSED END BUS BAY - TYPE "A"

DETAIL NO. **2266-1**

REVISED 5/17/06

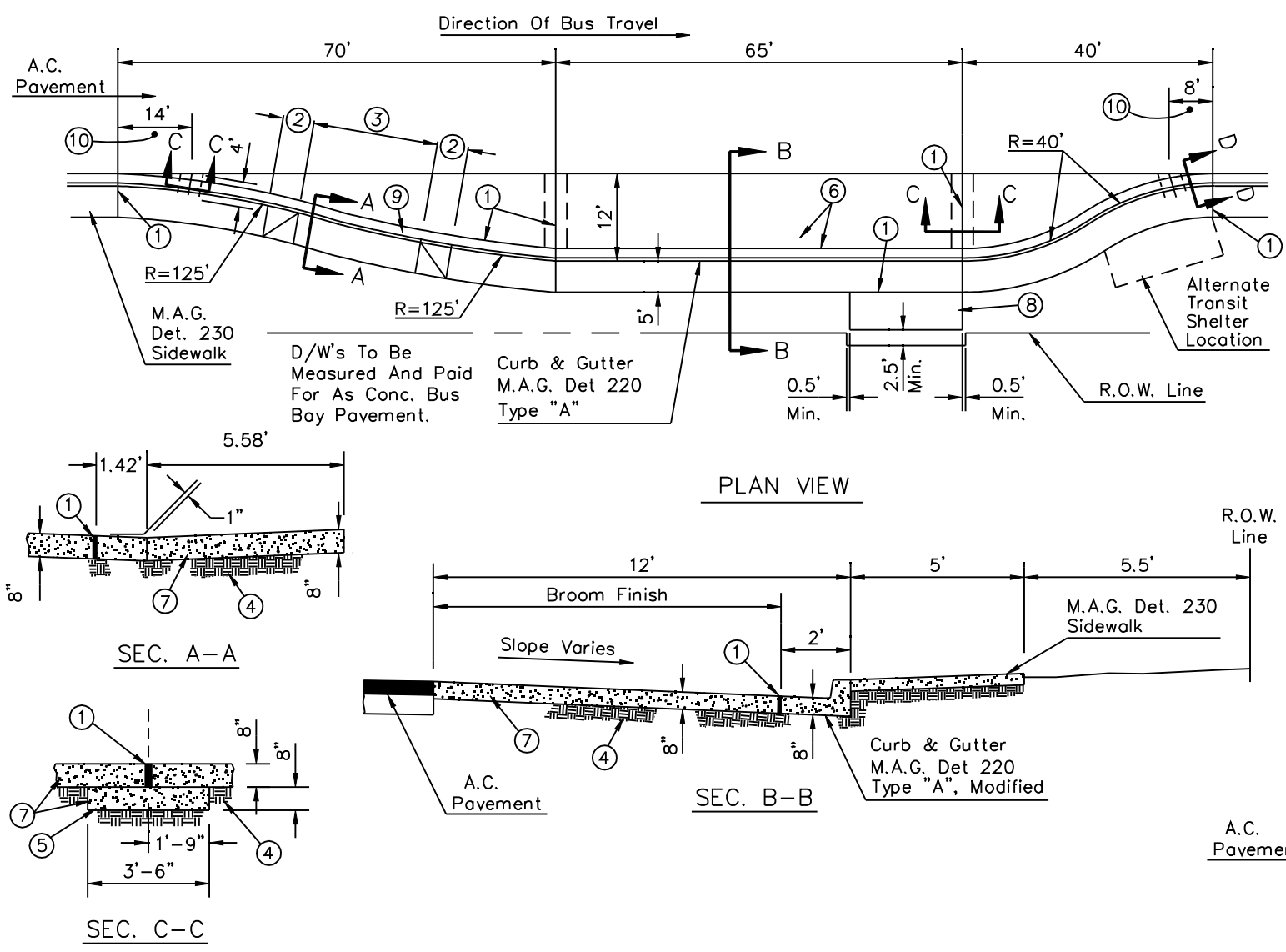

- ① 1/2" BITUMINOUS PREFORMED EXPANSION JOINT FILLER, A.S.T.M. D-1751 PER MAG SECTION 729.
- ② TRANSITION CURB FACE FROM 6" TO 0" HEIGHT IN 5'
- ③ D/W WIDTHS & LOCATIONS VARY, SEE PLANS. MAINTAIN 10' MIN. CLEARANCE BETWEEN DRIVEWAYS AND SHELTER PAD. WHEN DRIVEWAY WIDTH EXCEEDS 22', PROVIDE A CONTRACTION JOINT ON D/W C.
- ④ SUBGRADE PREPARATION PER MAG SECTION 301.
- ⑤ CONCRETE PAD TO BE POURED SEPARATELY FROM CONCRETE BUS BAY PAVEMENT.
- ⑥ CONTRACTION JOINTS IN THE BUS BAY PAVEMENT SHALL MATCH THOSE IN THE CURB.
- ⑦ CONCRETE SHALL BE CLASS "A" PER MAG SECTION 725
- ⑧ TRANSIT SHELTER PAD, PER COS STD DETAIL 2265.
- ⑨ NEW CONCRETE D/W TO BE POURED WITH BUS BAY PAVEMENT.
- ⑩ CURB & GUTTER TO BUS BAY PAVEMENT TRANSITION.

DETAIL NO. 2266-2	City of Scottsdale Standard Details	APPROVED BY: Scottsdale Standards & Specifications Committee	<h2 style="margin: 0;">CLOSED END BUS BAY - TYPE "B"</h2>	DETAIL NO. 2266-2
-----------------------------	---	--	---	-----------------------------

REVISED 5/17/06

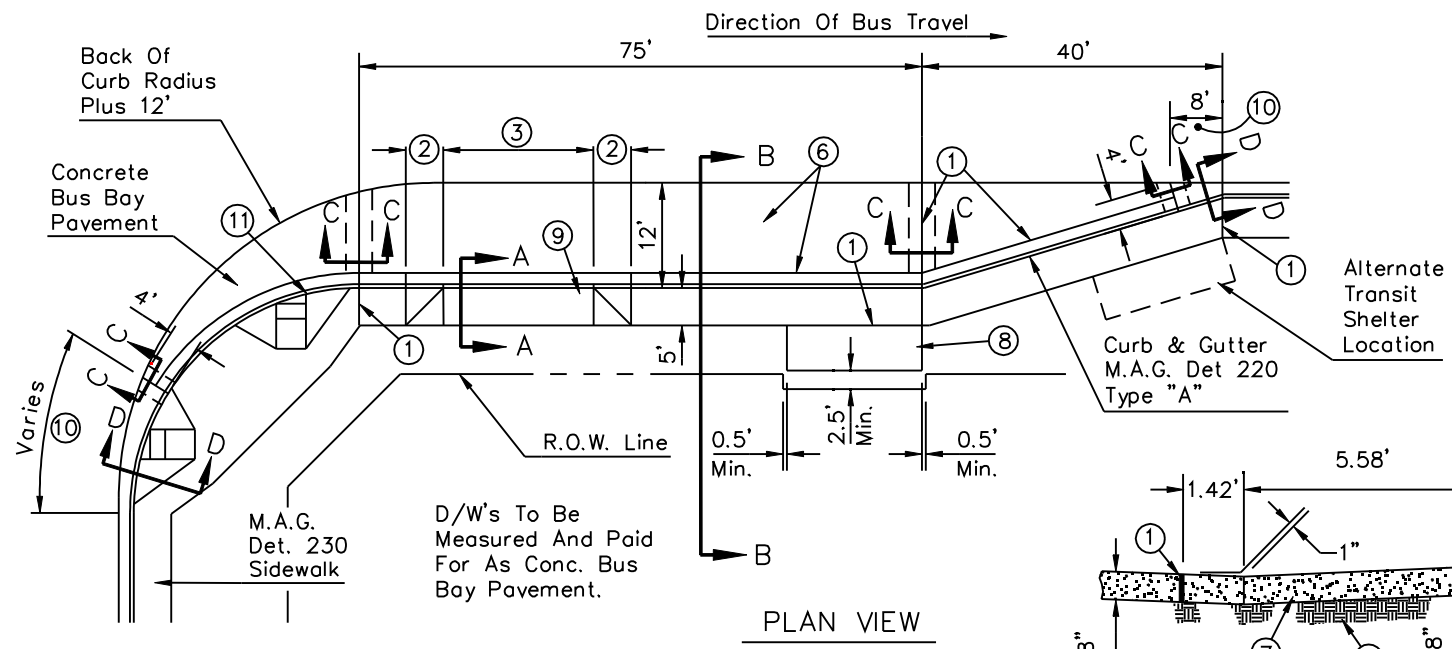

PLAN VIEW

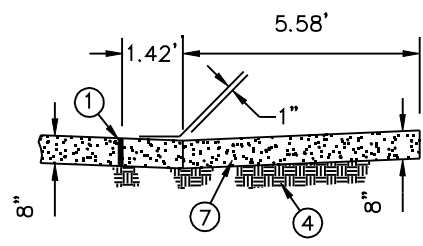

SEC. A-A

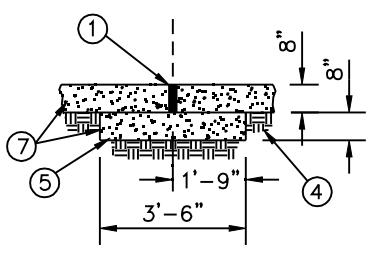

SEC. C-C

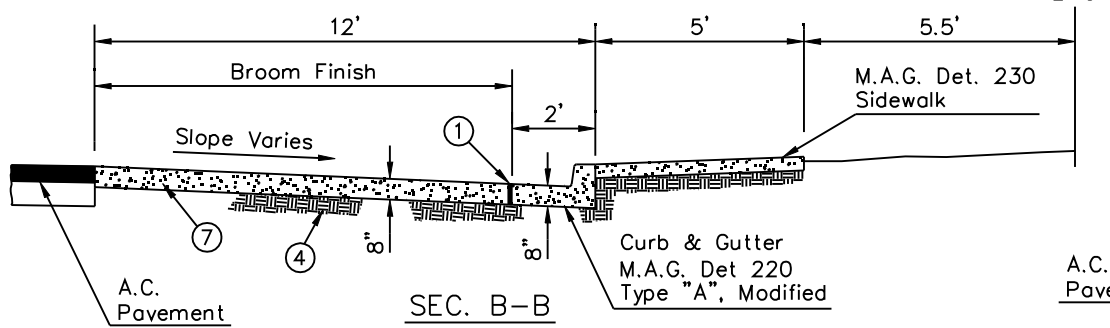

SEC. B-B

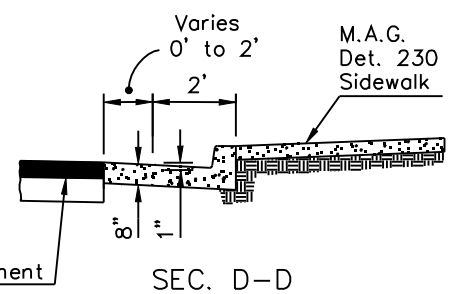

SEC. D-D

- ① 1/2" BITUMINOUS PREFORMED EXPANSION JOINT FILLER, A.S.T.M. D-1751 PER MAG SECTION 729.
- ② TRANSITION CURB FACE FROM 6" TO 0" HEIGHT IN 5'
- ③ D/W WIDTHS & LOCATIONS VARY, SEE PLANS. MAINTAIN 10' MIN. CLEARANCE BETWEEN DRIVEWAYS AND SHELTER PAD. WHEN DRIVEWAY WIDTH EXCEEDS 22', PROVIDE A CONTRACTION JOINT ON D/W CL.
- ④ SUBGRADE PREPARATION PER MAG SECTION 301.
- ⑤ CONCRETE PAD TO BE POURED SEPARATELY FROM CONCRETE BUS BAY PAVEMENT.
- ⑥ CONTRACTION JOINTS IN THE BUS BAY PAVEMENT SHALL MATCH THOSE IN THE CURB.
- ⑦ CONCRETE SHALL BE CLASS "A" PER MAG SECTION 725
- ⑧ TRANSIT SHELTER PAD, PER COS STD DETAIL 2265.
- ⑨ NEW CONCRETE D/W TO BE POURED WITH BUS BAY PAVEMENT.
- ⑩ CURB & GUTTER TO BUS BAY PAVEMENT TRANSITION.
- ⑪ CURB RADIUS AS SHOWN ON THE PLANS

DETAIL NO. 2267

City of Scottsdale Standard Details

APPROVED BY: Scottsdale Standards & Specifications Committee

FAR - SIDE BUS BAY

DETAIL NO. 2267

REVISED 7/1/97

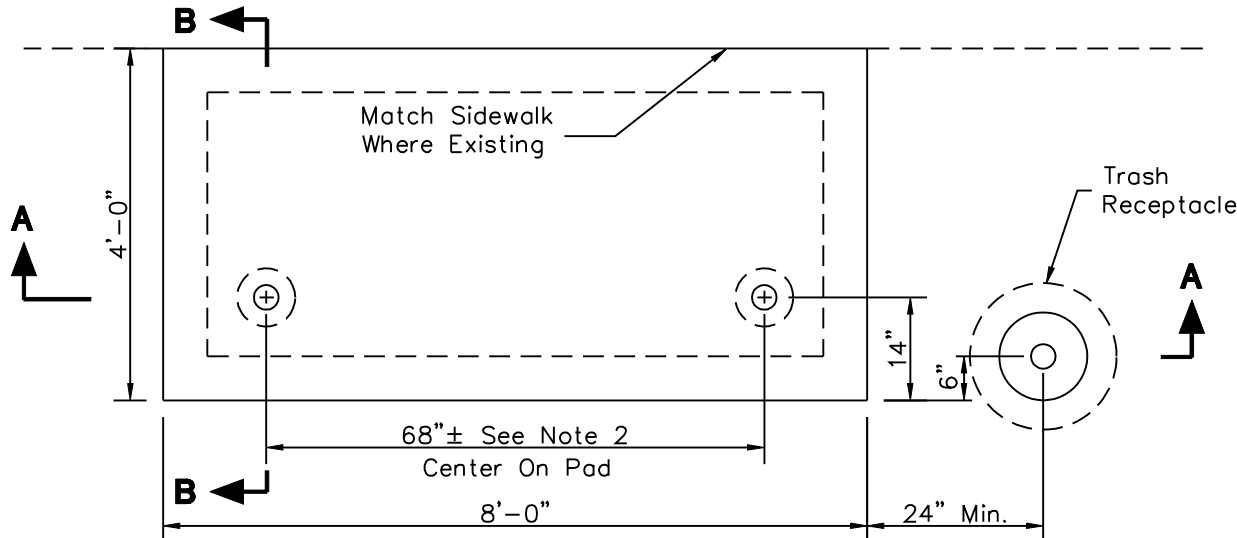

BASE SLAB PLAN

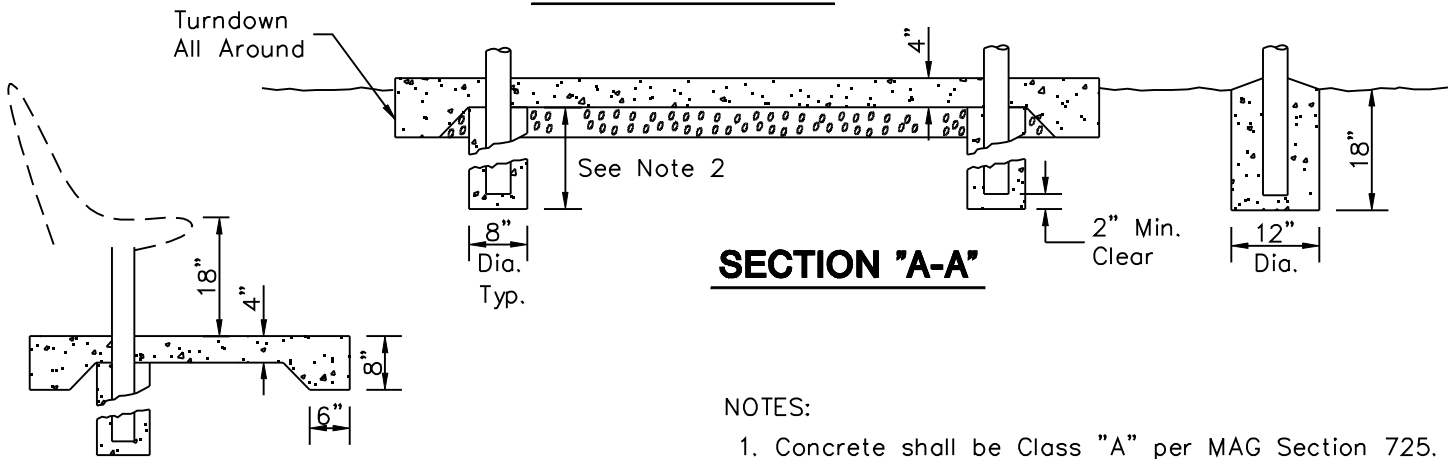

SECTION "A-A"

SECTION "B-B"

NOTES:

1. Concrete shall be Class "A" per MAG Section 725. Slab surface shall be trowel finish with salt pitted appearance and random sweat. Use integral color when specified on the plans.
2. Dimensions may vary with bench style - Verify and adjust to provide clearance and bench height shown.

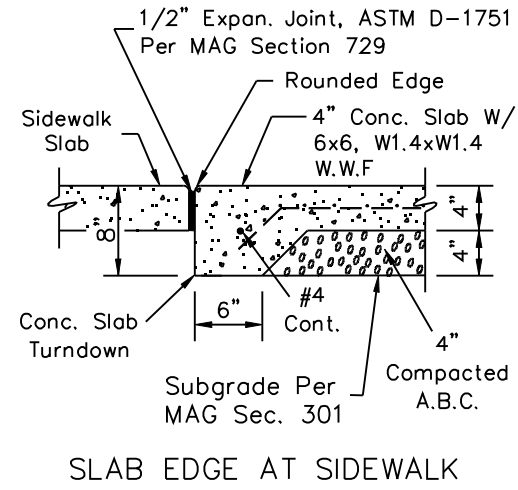

SLAB EDGE AT SIDEWALK

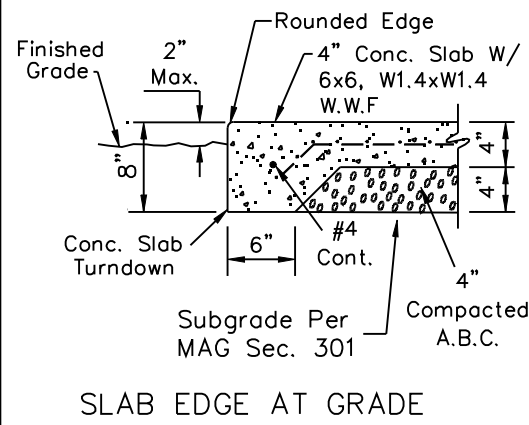

SLAB EDGE AT GRADE

DETAIL NO.
2268

**City of Scottsdale
Standard Details**

APPROVED BY:
**Scottsdale Standards &
Specifications Committee**

**BASE SLAB AND FOUNDATIONS FOR
BUS STOP BENCH AND RECEPTACLES**

DETAIL NO.
2268

REVISED 4/28/08

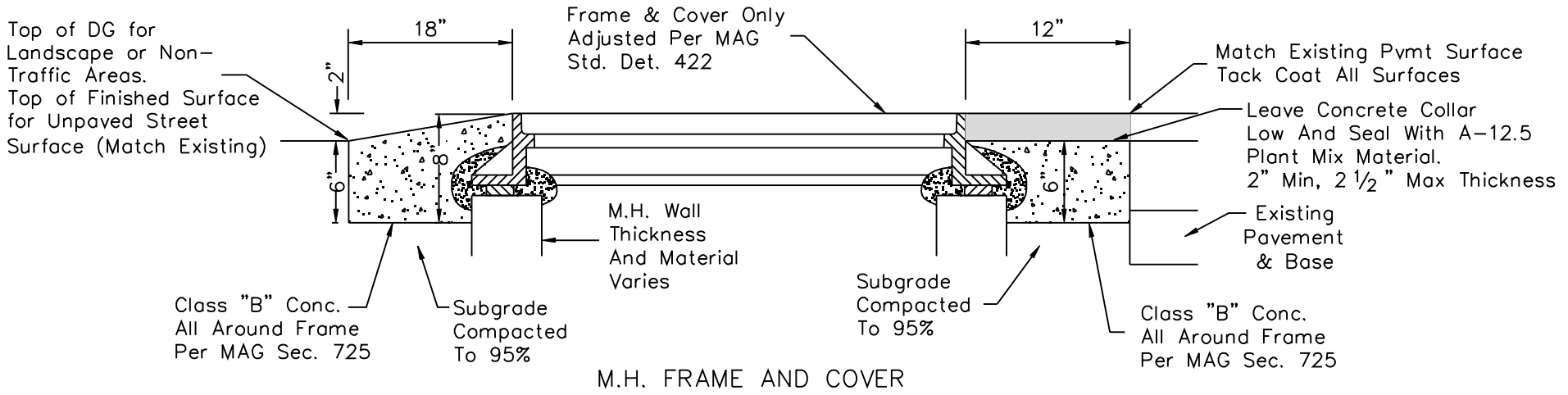

UNPAVED LOCATIONS

PAVED LOCATIONS

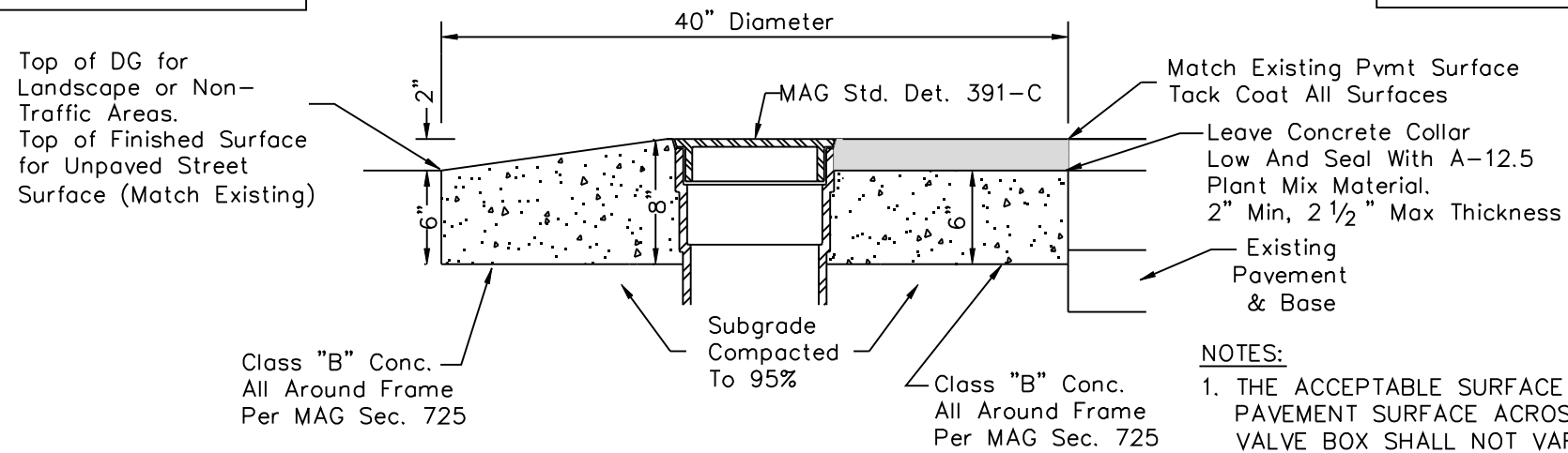

NOTES:

1. THE ACCEPTABLE SURFACE PROFILE FROM THE PAVEMENT SURFACE ACROSS THE MANHOLE OR VALVE BOX SHALL NOT VARY MORE THAN 1/4 INCH FROM THE LOWER EDGE OF A 12 FOOT STRAIGHTEDGE WHEN THE STRAIGHTEDGE IS PLACED PARALLEL AND PERPENDICULAR TO THE CENTERLINE OF THE ROADWAY.

REVISED 3/10/09

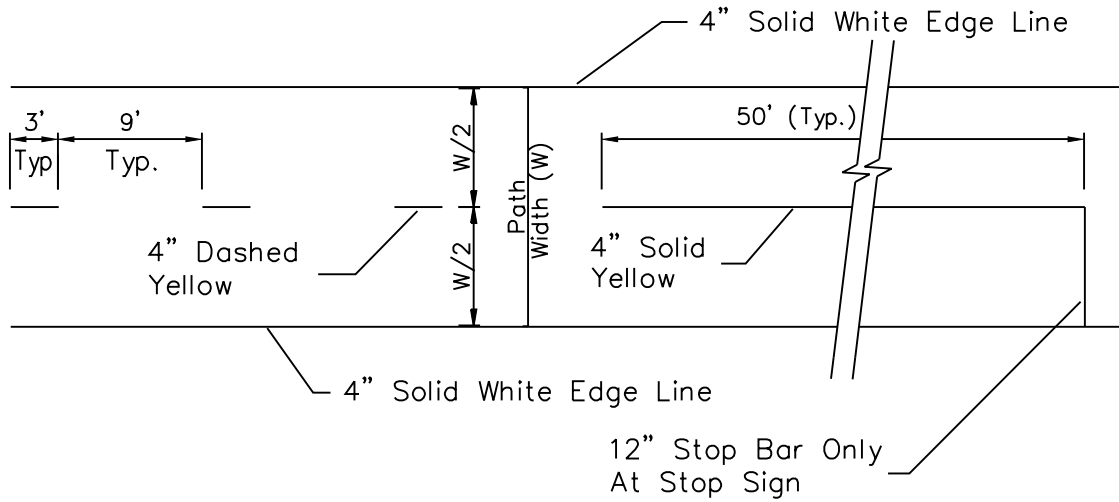

MULTI USE PATH STRIPING DETAILS

NOTE:

Striping shall be reflectorized paint with glass beads per ADOT Standard Specifications Section 708.

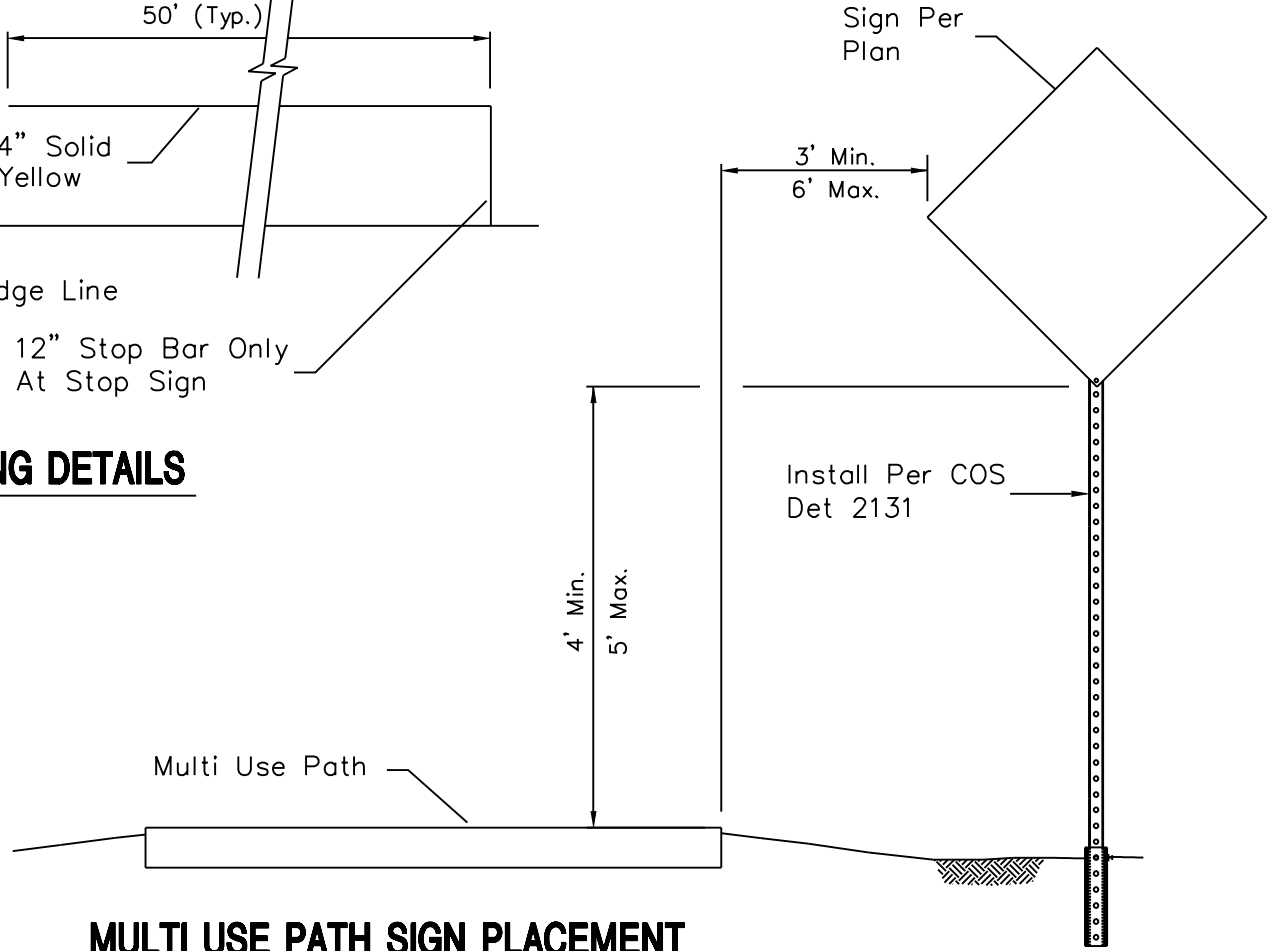

MULTI USE PATH SIGN PLACEMENT

DETAIL NO.
2282

City of Scottsdale
Standard Details

APPROVED BY:
Scottsdale Standards & Specifications Committee

MULTI USE PATH STRIPING AND SIGNING

DETAIL NO.
2282

REVISED 3/10/09

* See Shoulder Detail

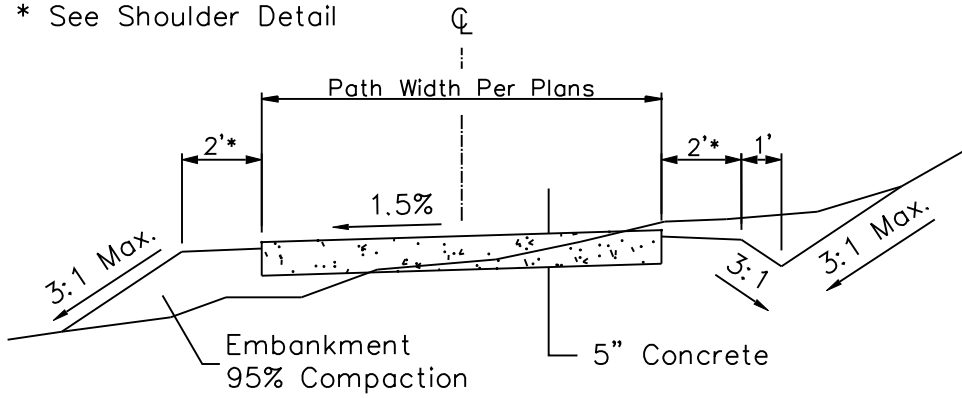

MULTI USE PATH DETAIL

* See Shoulder Detail

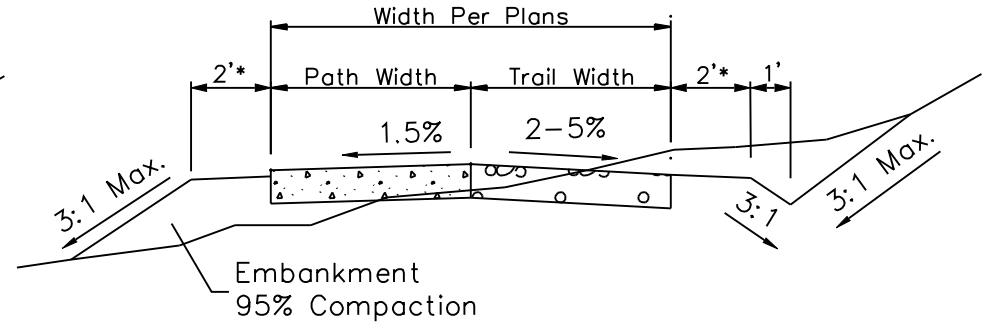

MULTI USE PATH WITH TRAIL DETAIL

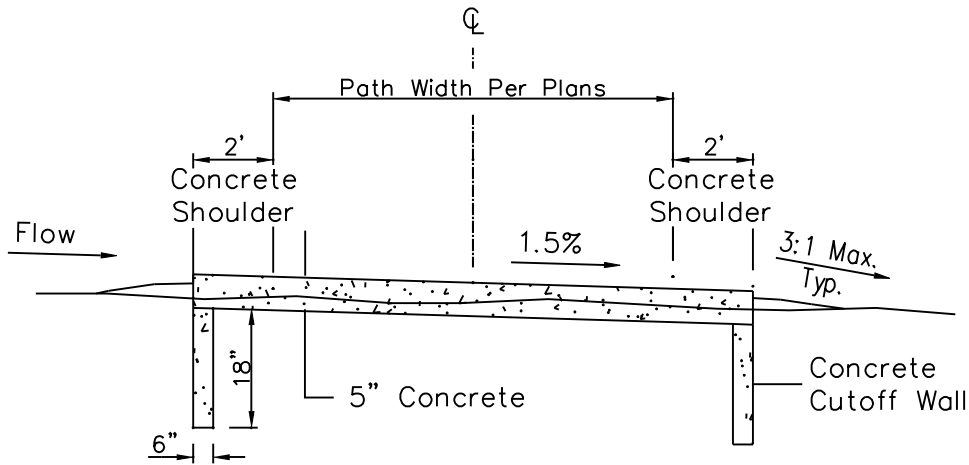

MULTI USE PATH WET AREA CROSSING

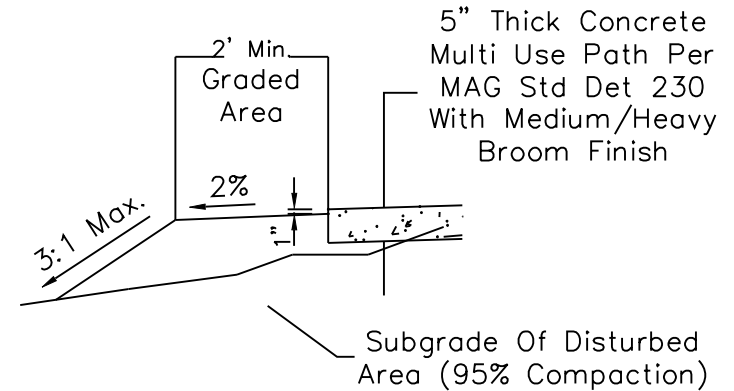

SHOULDER DETAIL

DETAIL NO.
2283

**City of Scottsdale
Standard Details**

APPROVED BY:
**Scottsdale Standards &
Specifications Committee**

MULTI USE PATH DETAILS

DETAIL NO.
2283

REVISED 4/24/07

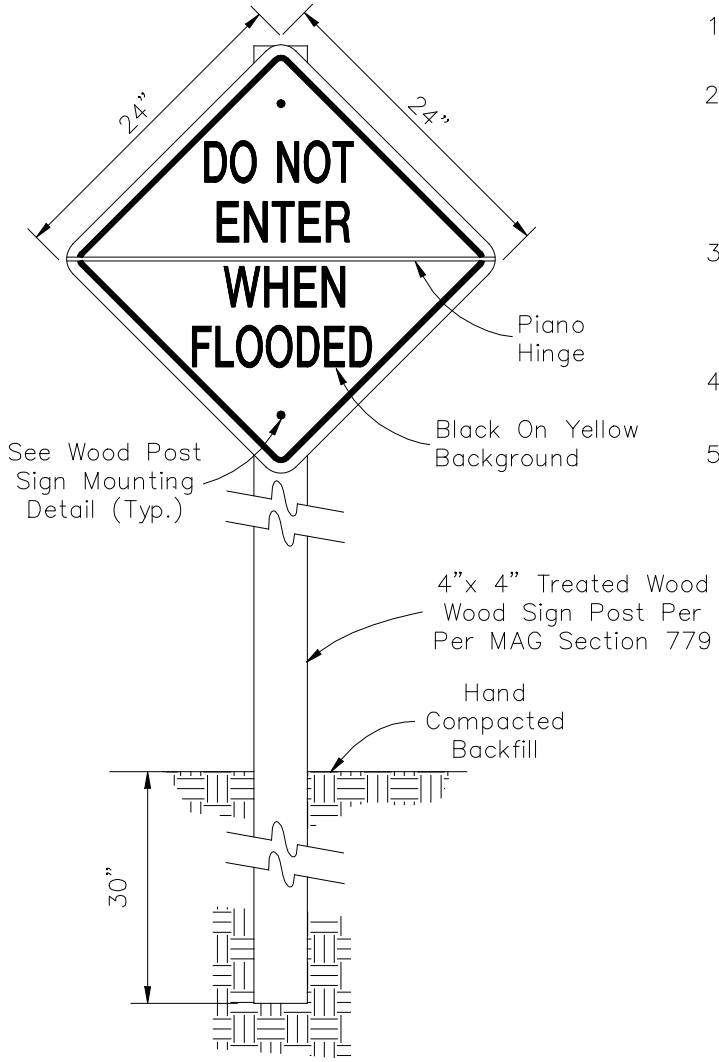

NOTES:

1. Signs shall conform to C.O.S. Supplemental Specifications, Section 402.3.
2. Signs to be mounted on square perforated tubing per C.O.S. Std Det 2131 within C.O.S. Right-of-Way. Treated wood post may be used for trail markers located outside C.O.S. Right-of Way.
3. Background and legends shall be ASTM Type IV reflective sheeting. Black legends shall be opaque (colors as noted) unless otherwise approved by the City of Scottsdale.
4. Sign height and placement shall conform to C.O.S. Std. Det. 2282.
5. For additional information regarding sign fabrication, contact the City of Scottsdale Sign Shop, 480-312-5646.

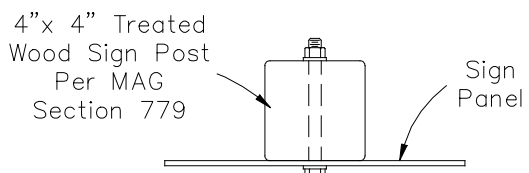

Fasten With (2) 1/2" x 2" Lag Screws With (2) Flat Washers or (2) 1/2" x 4 1/2" Bolts With (4) Flat Washers. Burr Threads And Nuts With Center Punch.

WOOD POST SIGN MOUNTING DETAIL

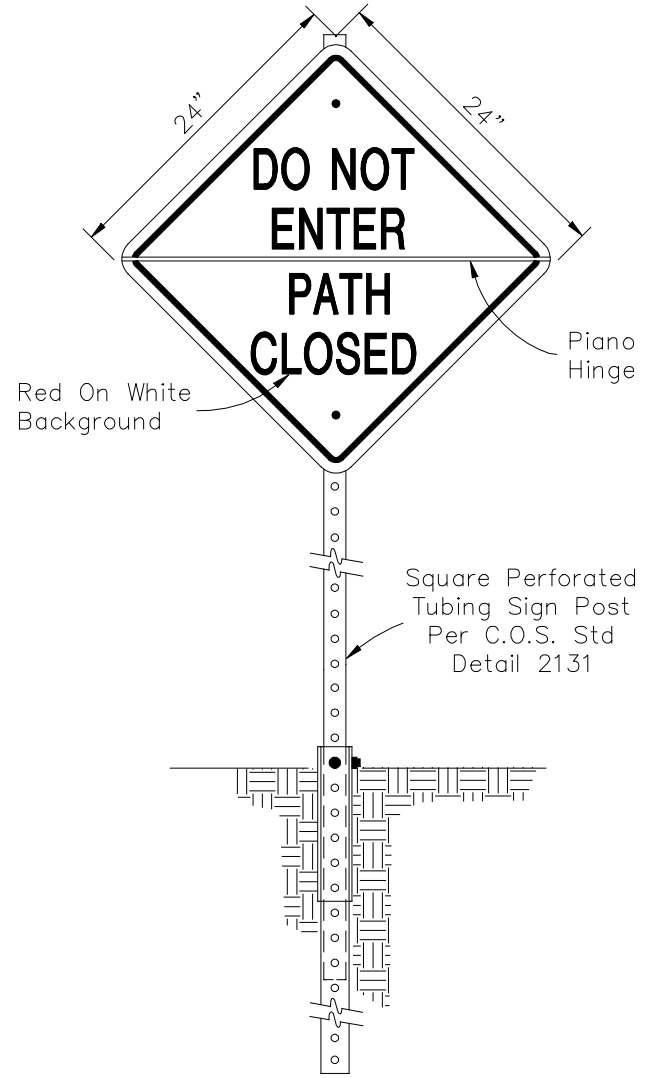

MULTI-USE PATH WET CROSSING SIGN

DETAIL NO. 2284	City of Scottsdale Standard Details	APPROVED BY: Scottsdale Standards & Specifications Committee	MULTI-USE PATH WET CROSSING SIGN	DETAIL NO. 2284
---------------------------	---	--	---	---------------------------

REVISED 5/09/07

Upright Supports
1 1/2" O.D.
Steel Tubing,
11 Gauge
Weld To Base

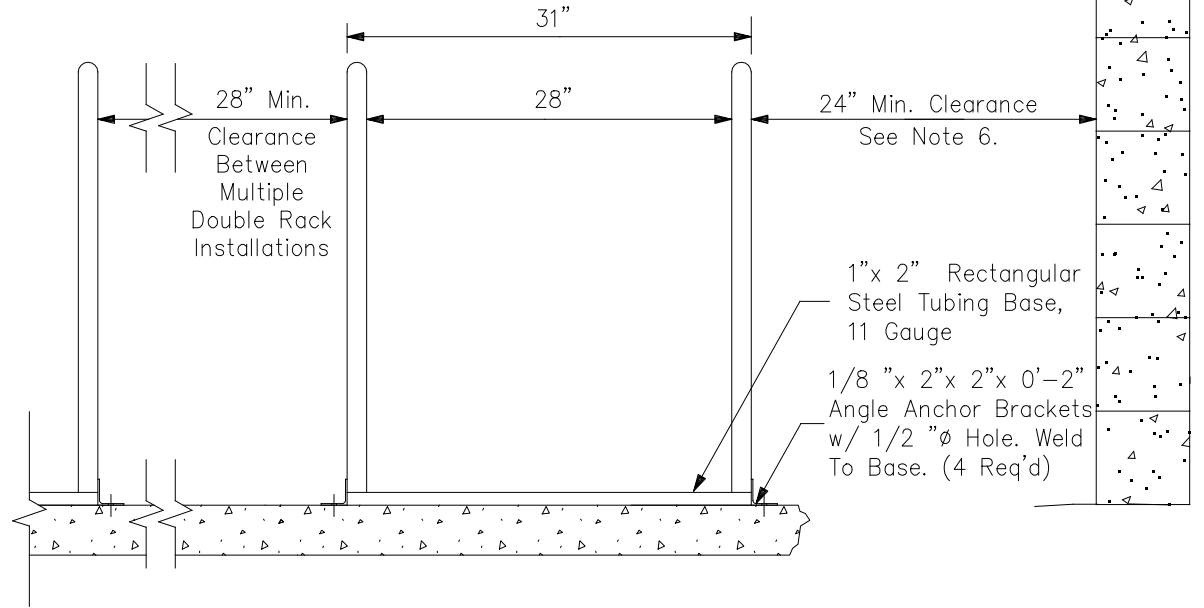
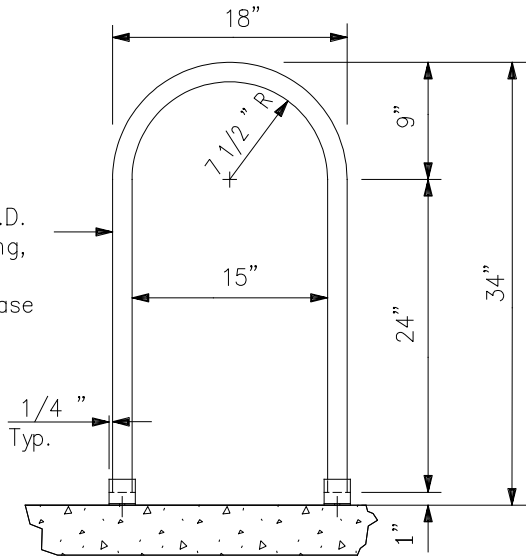

NOTES:

1. Double rack holds 4 bicycles.
2. Finish to be weather resistant, baked-on powder polymer coating.
3. Anchor rack to concrete w/ 3/8" ϕ x 2 1/2" wedge anchors and tamper resistant or welded nuts, (4 Req'd) or set tubing 12" below grade in 24" deep x 6" wide concrete footing.
4. Concrete base may be covered with turf or decomposed granite.
5. Placement of bicycle rack shall be convenient to main entrance and in a highly visible area.
6. 24" Min. clearance from walls or obstructions including curbs or edge of roadway on both sides and back of rack. Front of rack shall have a 6' min clear area.

1/8" x 2" x 2" x 0'-2"
Angle Anchor Brackets
w/ 1/2" ϕ Hole. Weld
To Base. (4 Req'd)

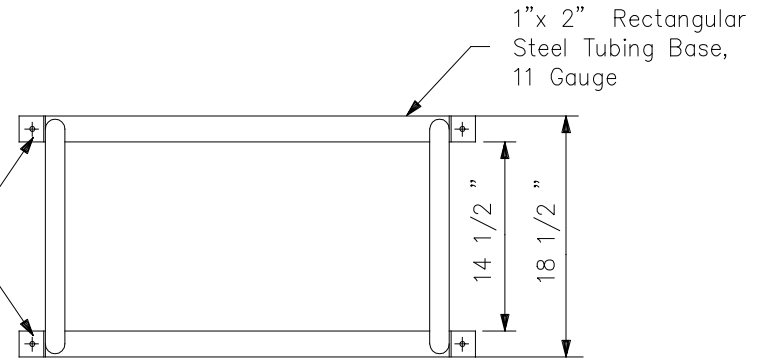

DETAIL NO.
2285

**City of Scottsdale
Standard Details**

APPROVED BY:
**Scottsdale Standards &
Specifications Committee**

DOUBLE BICYCLE RACK

DETAIL NO.
2285

REVISED 3/31/10

CURVE DATA - TO BACK OF CURB			
CURVE	RADIUS	LENGTH	DELTA
C1	0.50'	1.43'	164°12'35"
C2	80.00'	22.05'	15°47'25"
C3	3.00'	9.42'	180°00'00"

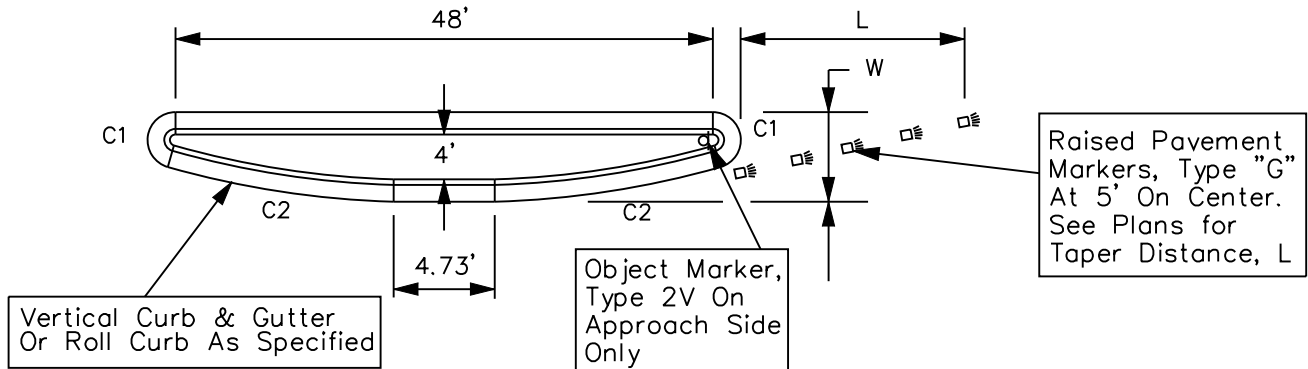

SIDE ISLAND DETAIL

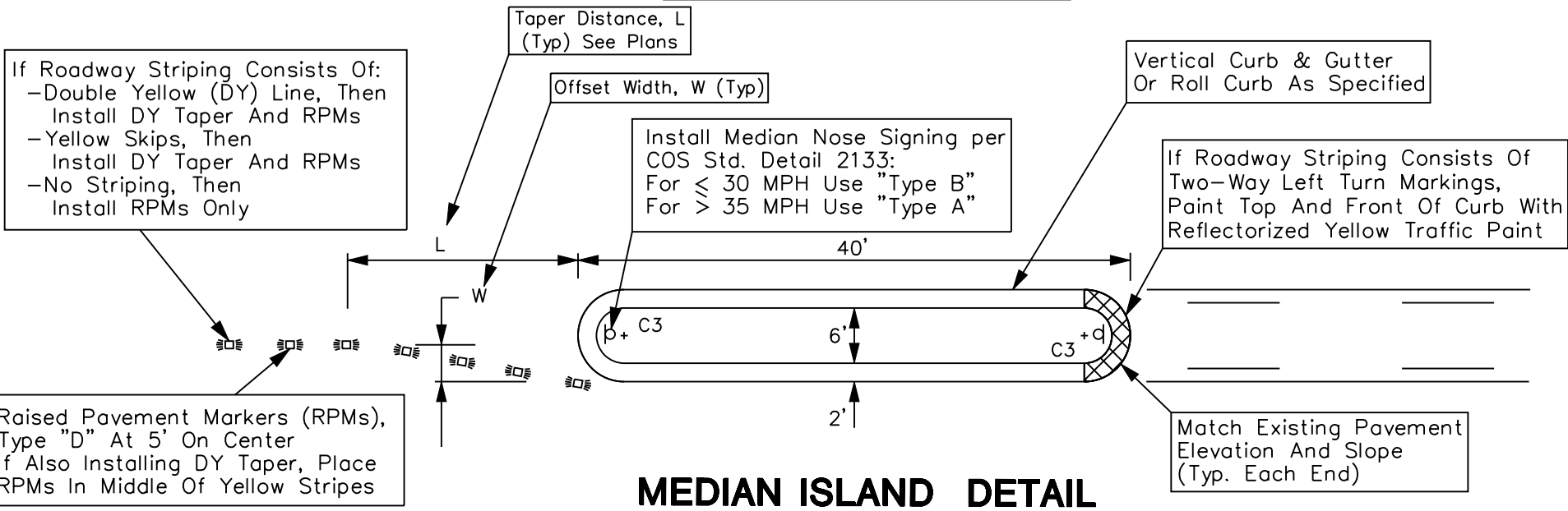

MEDIAN ISLAND DETAIL

REVISED 05/01/07

CURVE DATA - TO BACK OF CURB			
CURVE	RADIUS	LENGTH	DELTA
C1	80.00'	21.98'	15°44'26"

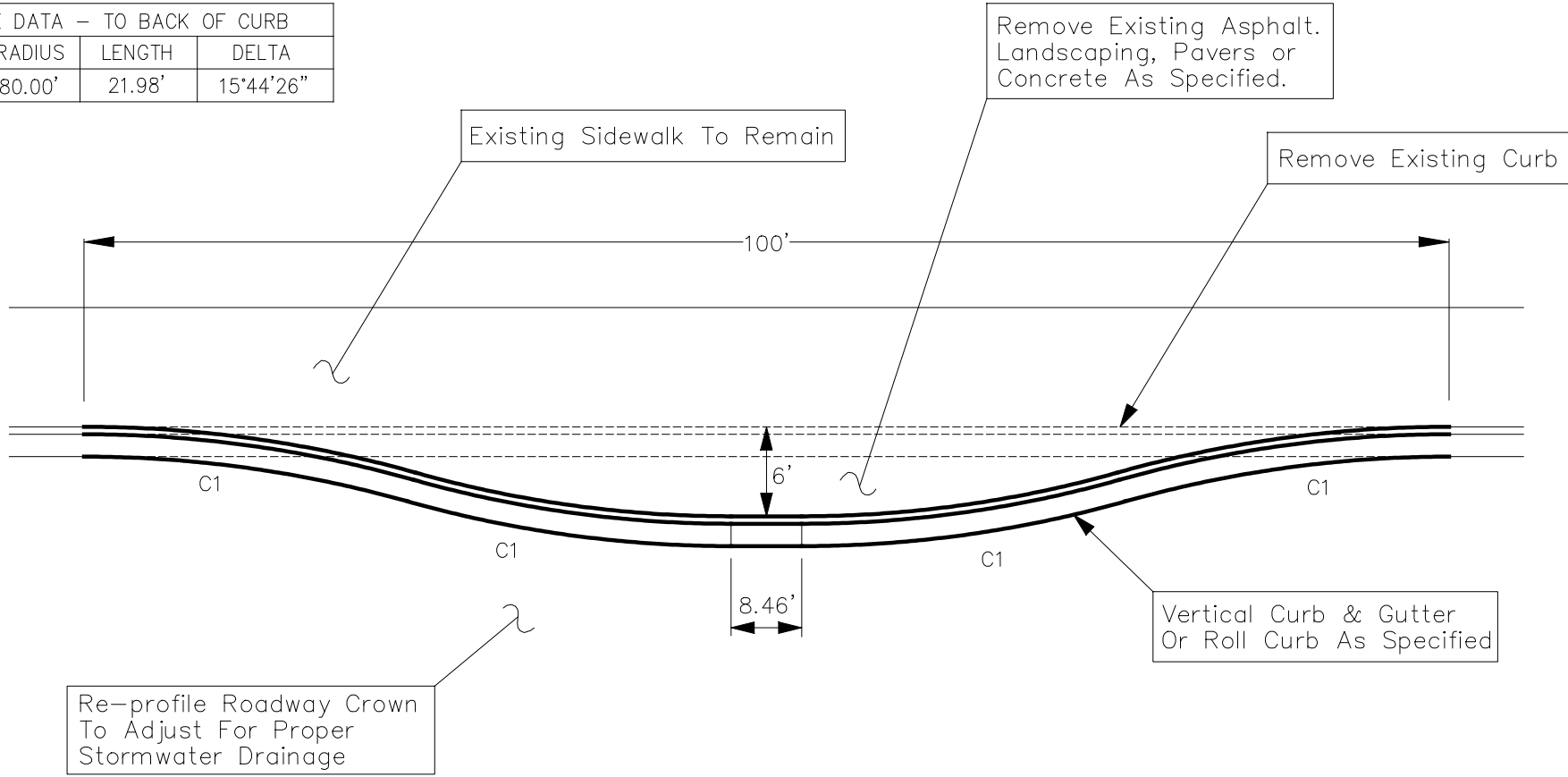

BULB OUT / CHOKER DETAIL

DETAIL NO. **2290-2** **City of Scottsdale**
Standard Details

APPROVED BY:
Scottsdale Standards & Specifications Committee

BULB OUT/CHOKER DETAIL

DETAIL NO. **2290-2**

REVISED 12/6/11

Adjust Manhole Or Valve
Frame & Cover Per COS
Det 2270 (Where Required)

New A.C. Pavement (A-12.5)

Rotomill Existing
AC Pavement

6" Solid White Line
For Bike Lane And
"BUMP" Legend In
Bike Lane Approach
(Where Required)

6'x6' Solid White Chevron (Typ.)
See Chevron Detail On
COS Std. Detail 2292-2

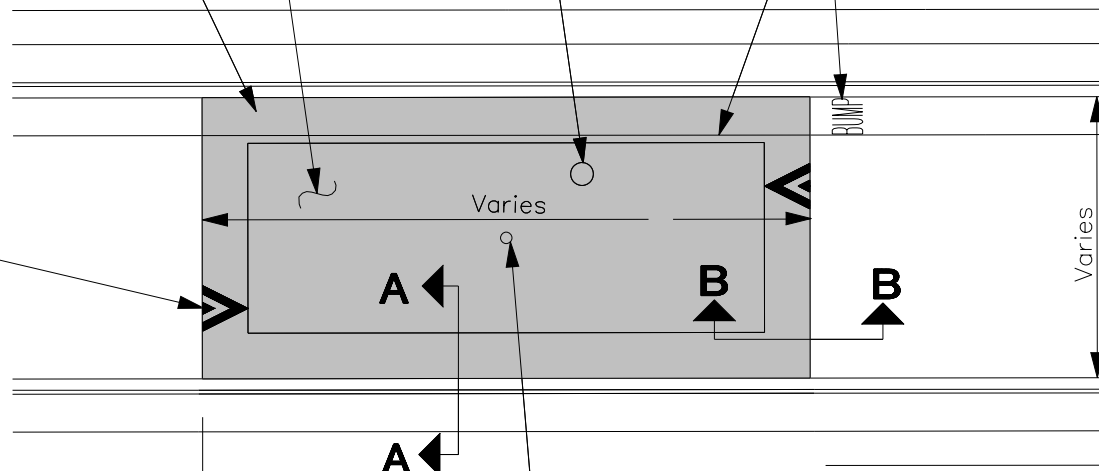

W-Series Sign or
As Specified, Typical
Both Directions.

Distance Varies
As Specified

Install Frame & Cover Over
Existing Survey Monument
Per MAG Det 120, Type 'A'
(Where Required)

NOTE: For Sections A-A And B-B See COS Std. Detail 2292-2.

DETAIL NO.
2292-1

**City of Scottsdale
Standard Details**

APPROVED BY:
**Scottsdale Standards &
Specifications Committee**

SPEED TABLE DETAILS

DETAIL NO.
2292-1

REVISED 4/23/09

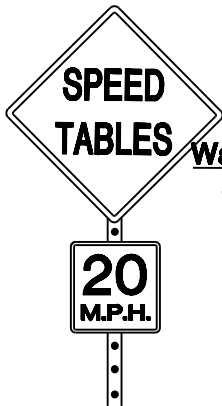

Warning Sign
30" x 30"

W13-1
18" x 18"

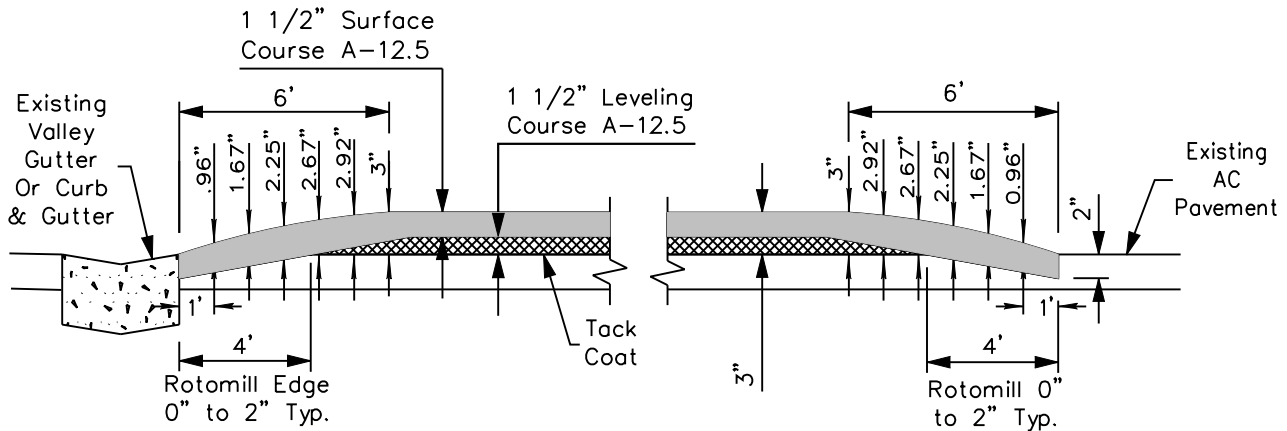

SECTION A-A
MATCH EX. CONCRETE
TYPICAL ALL LOCATIONS

SECTION B-B
MATCH EX. AC PAVEMENT
TYPICAL ALL LOCATIONS

Edge of Pavement
Or Travel Lane

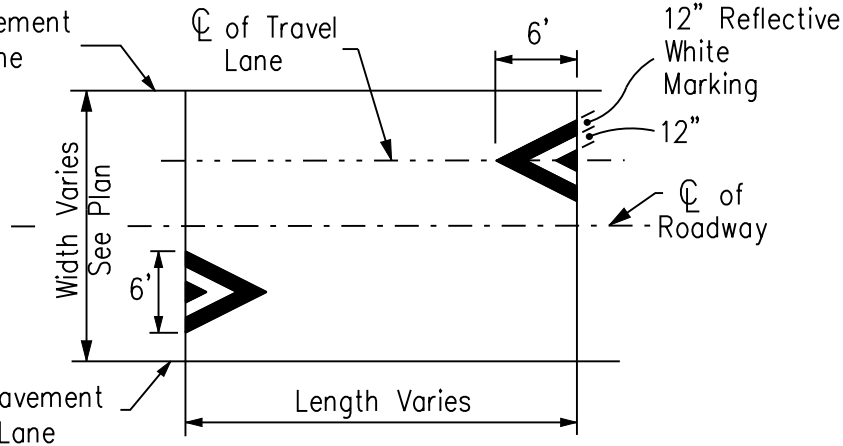

CHEVRON DETAIL

DETAIL NO.
2292-2

City of Scottsdale
Standard Details

APPROVED BY:
Scottsdale Standards & Specifications Committee

SPEED TABLE DETAILS

DETAIL NO.
2292-2

REVISED 12/5/11

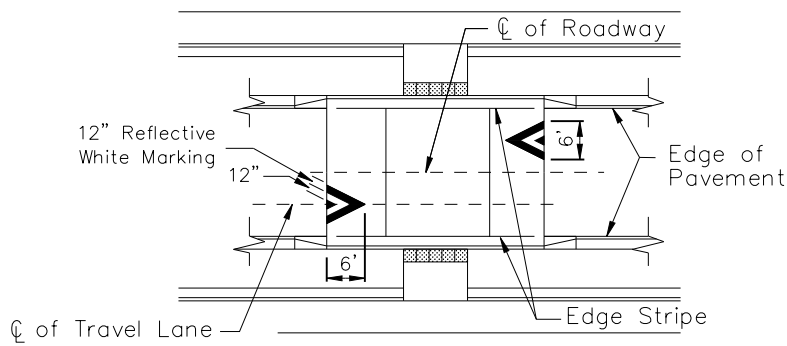

Chevron Detail

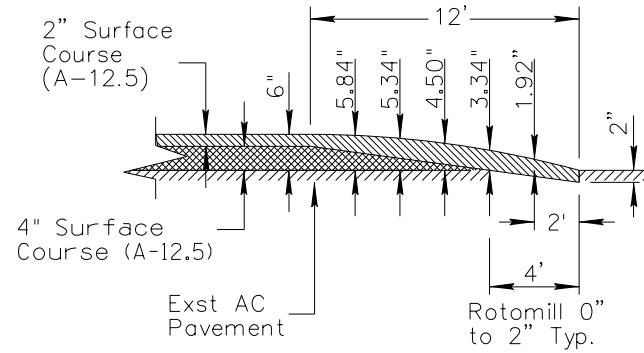

Section A-A

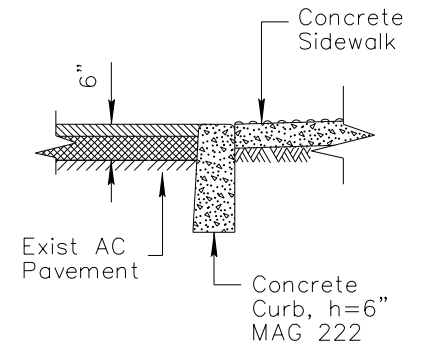

Section B-B

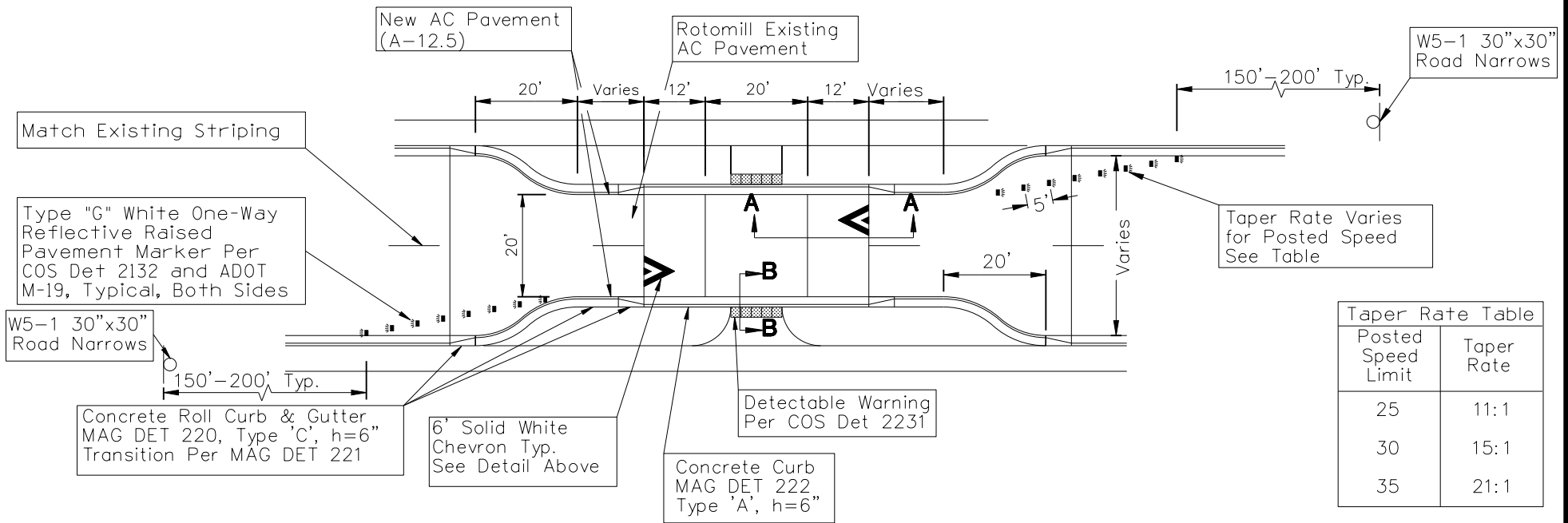

Taper Rate Varies for Posted Speed See Table

Posted Speed Limit	Taper Rate
25	11:1
30	15:1
35	21:1

DETAIL NO.
2293

**City of Scottsdale
Standard Details**

APPROVED BY:
**Scottsdale Standards &
Specifications Committee**

MID-BLOCK PEDESTRIAN TABLE

DETAIL NO.
2293

REVISED 5/25/07

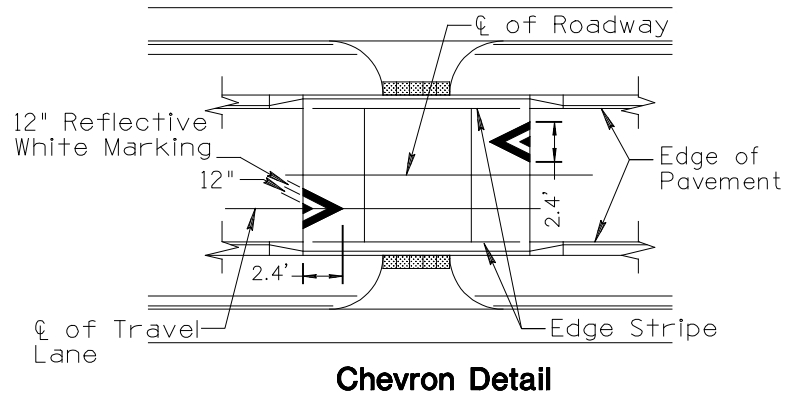

Chevron Detail

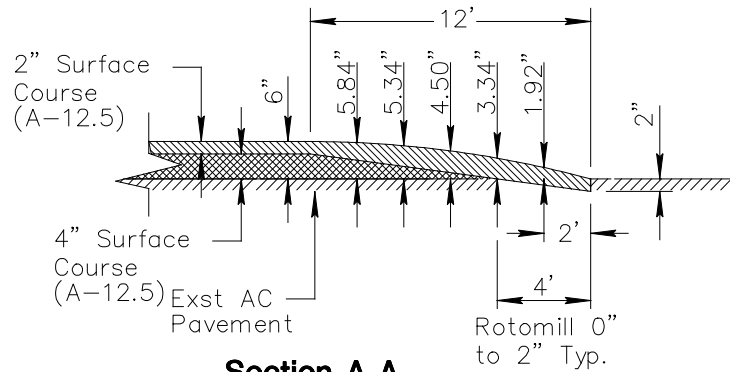

Section A-A

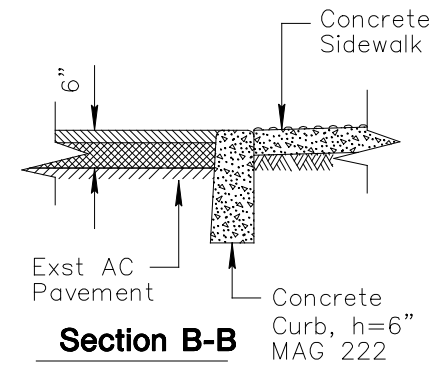

Section B-B

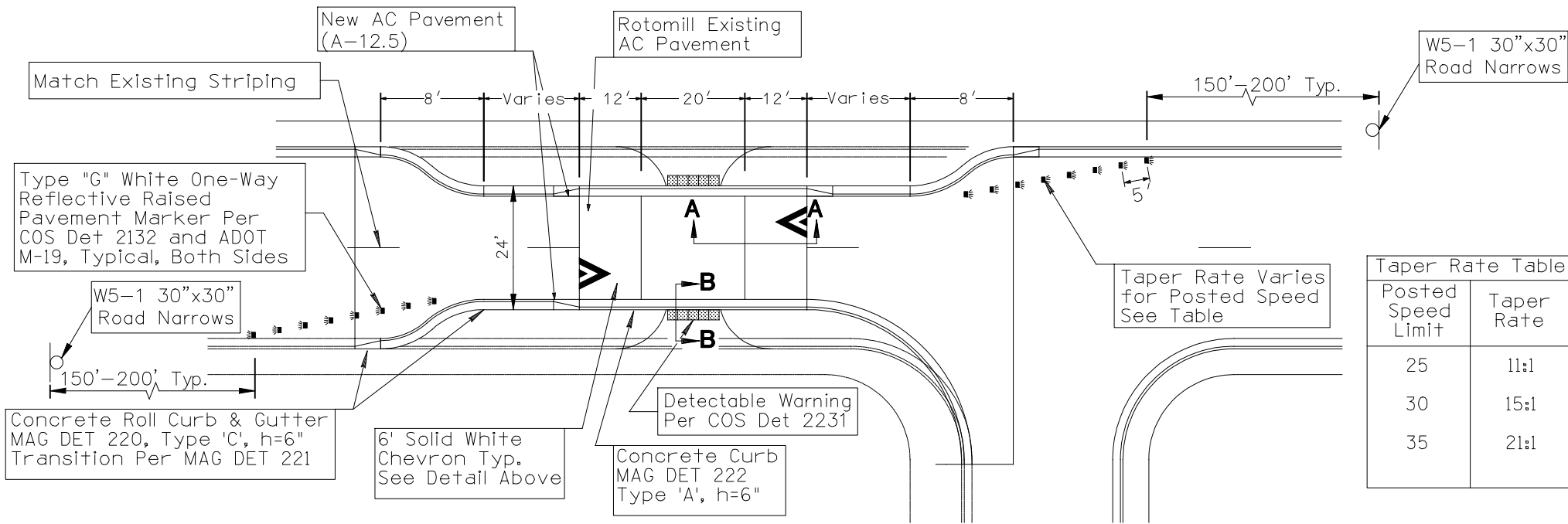

Taper Rate Varies for Posted Speed See Table

Posted Speed Limit	Taper Rate
25	11:1
30	15:1
35	21:1

REVISED 3/31/10

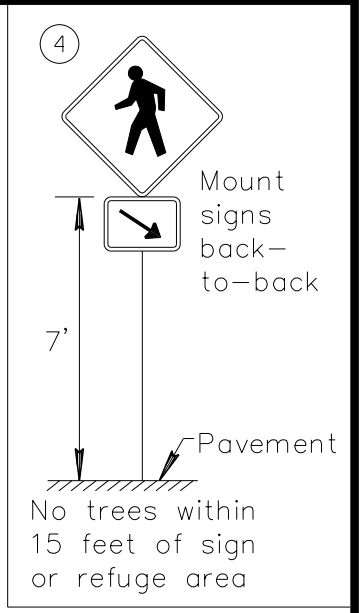
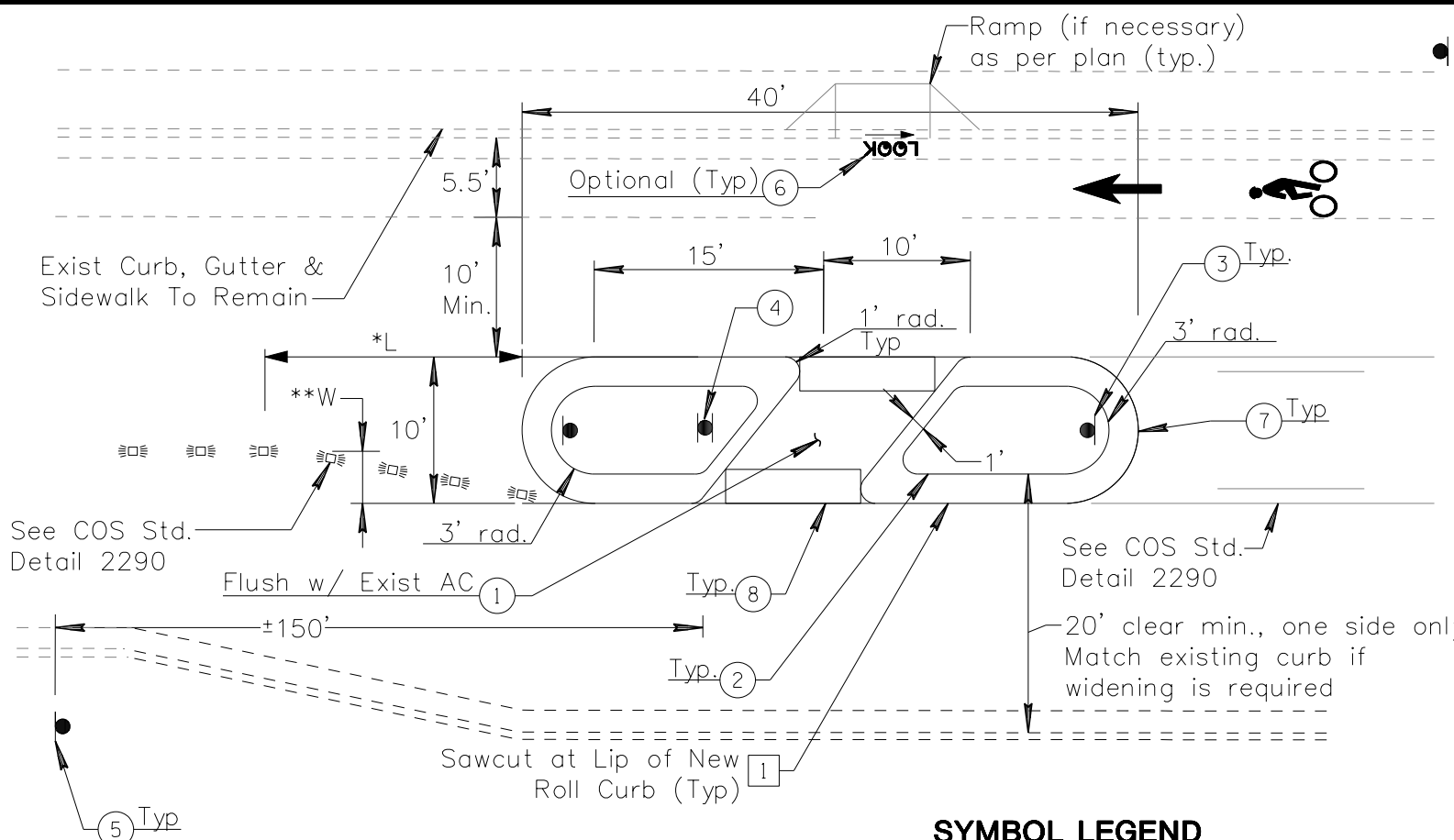

SYMBOL LEGEND

- ① Sawcut & Remove AC Pavement
- ② Roll Curb per MAG Det 220 Type D
- ③ Install Median Nose Signing Per COS Std. Detail 2133
- ④ 30" x 30" W11-2 above
24" x 12" W16-7p-R below
- ⑤ If posted speed \geq 40 mph, install advance 30" x 30" W11-2
- ⑥ 9" text w/arrow (optional)
- ⑦ Match existing pavement elevation and slope
- ⑧ Detectable Warning Surface per COS Det. 2231

* L= Taper Distance
(See Plans)
**W= Offset Distance

DETAIL NO.
2295

**City of Scottsdale
Standard Details**

APPROVED BY:
**Scottsdale Standards &
Specifications Committee**

PEDESTRIAN REFUGE

DETAIL NO.
2295

REVISED 4/17/09

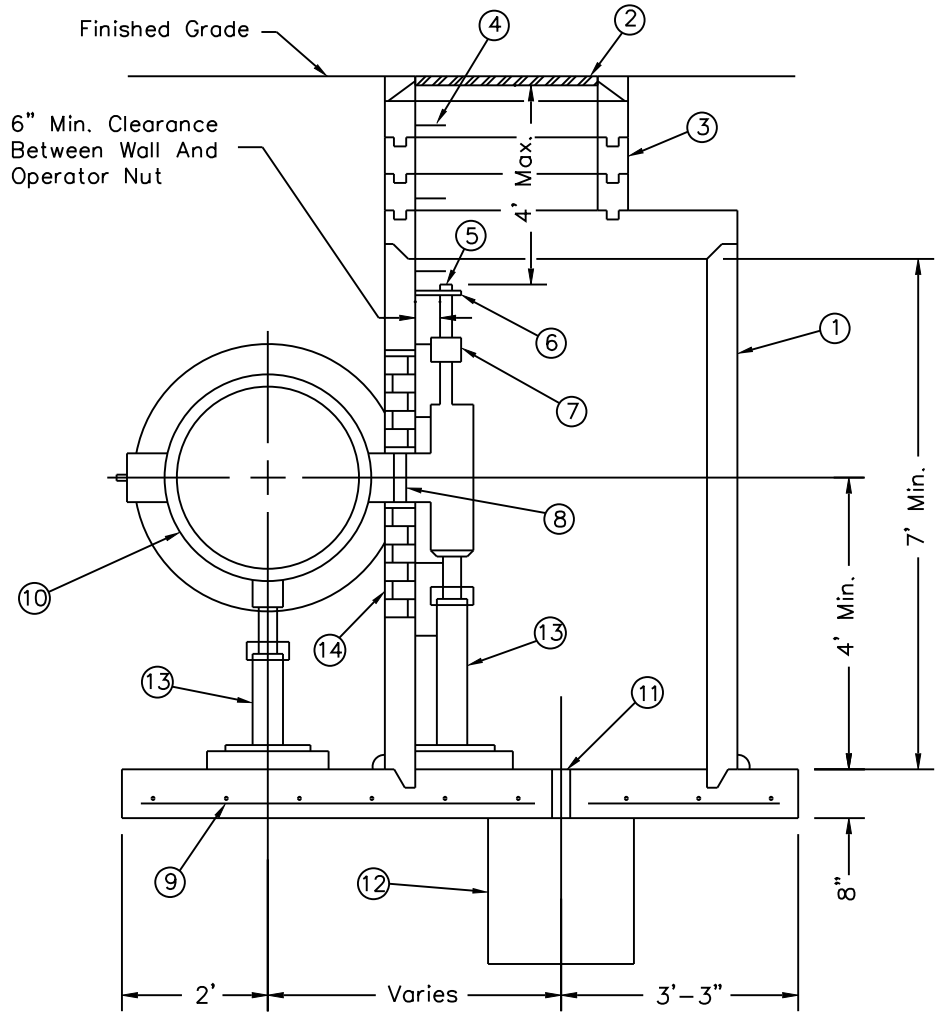

LEGEND

- ① 48" I.D. Manhole Shaft Per MAG Std. Detail 420, Type "B" Top
- ② 32" Hinged Manhole Frame & Cover Per COS Specifications Section 610.8
- ③ Grouted Adjusting Rings
- ④ Polypropylene Manhole Steps Per MAG Std. Detail 428, 12" Spacing Typical
- ⑤ Operator Nut
- ⑥ Wall Bracket
- ⑦ Packing Gland
- ⑧ 6" Extension
- ⑨ #4 Rebar 12" On Center Each Way 2" Clear Typical
- ⑩ Butterfly Valve
- ⑪ 3" Diameter Drain
- ⑫ 8 Cu. Ft. Gravel Sump
- ⑬ Adjustable Pipe Saddle Support
- ⑭ Rectangular Cut-Out In Manhole Shaft, Fill Space Between Shaft And Pipe With 1" Sheet Foam, Brick And Mortar

SECTION

DETAIL NO.
2305-1

City of Scottsdale
Standard Details

APPROVED BY:
Scottsdale Standards & Specifications Committee

BUTTERFLY VALVE OPERATOR MANHOLE

DETAIL NO.
2305-1

REVISED 1/14/93

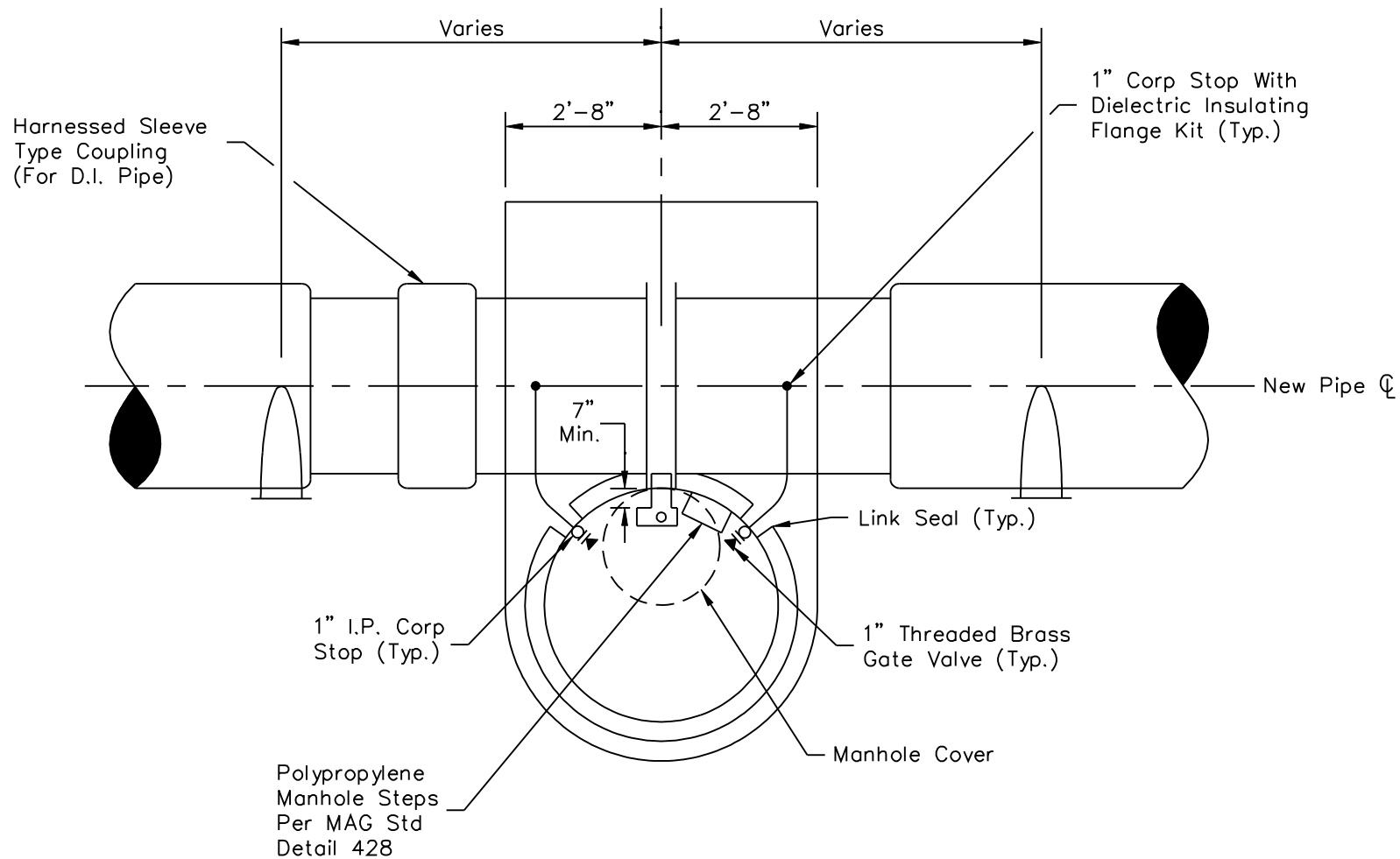

PLAN

DETAIL NO.
2305-2

**City of Scottsdale
Standard Details**

APPROVED BY:
**Scottsdale Standards &
Specifications Committee**

BUTTERFLY VALVE OPERATOR MANHOLE

DETAIL NO.
2305-2

REVISED 2/22/99

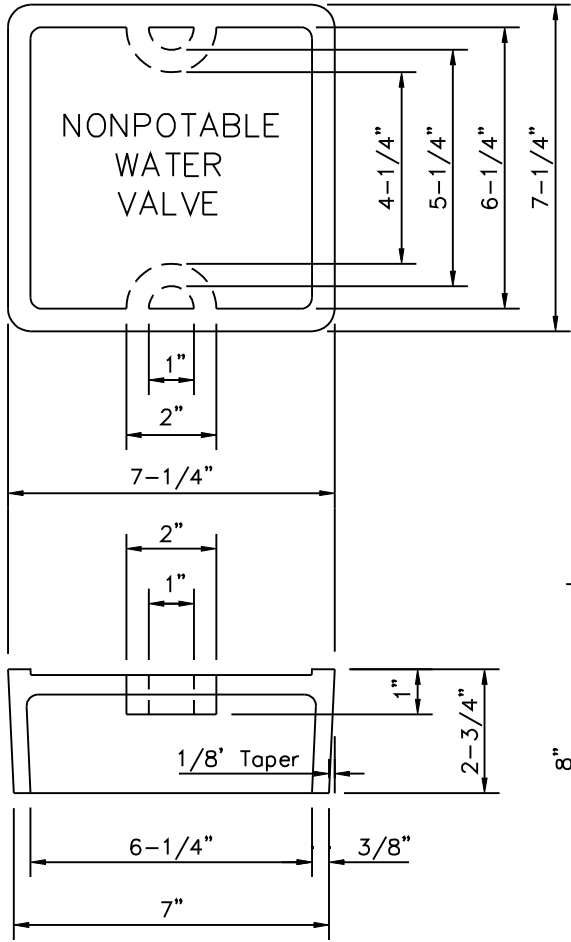

Class 'B' Conc. Collar
All Around Frame
Per MAG Sec. 725

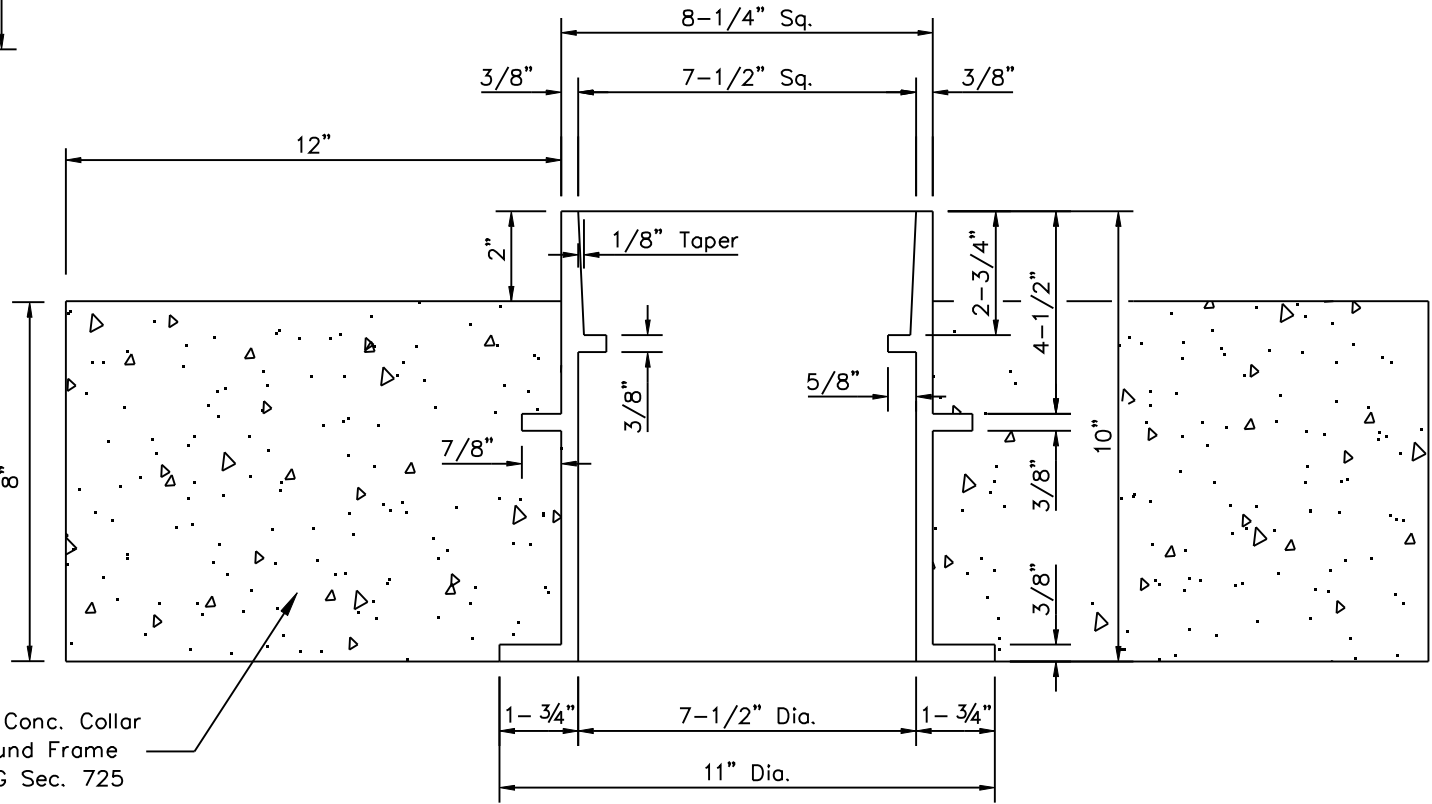

NOTES

1. Round bottom for riser pipe, square top for cover.
2. All materials shall be cast iron per ASTM A48, Class 30B.
3. Nonpotable water valve box to be installed per M.A.G. Std. Detail 391.
4. The cast iron lid shall be marked "Nonpotable Water Valve" on the top side. Letters shall be 1" each and raised 1/8".

DETAIL NO.
2315

**City of Scottsdale
Standard Details**

APPROVED BY:
**Scottsdale Standards &
Specifications Committee**

NONPOTABLE WATER VALVE BOX & COVER

DETAIL NO.
2315

REVISED 4/24/07

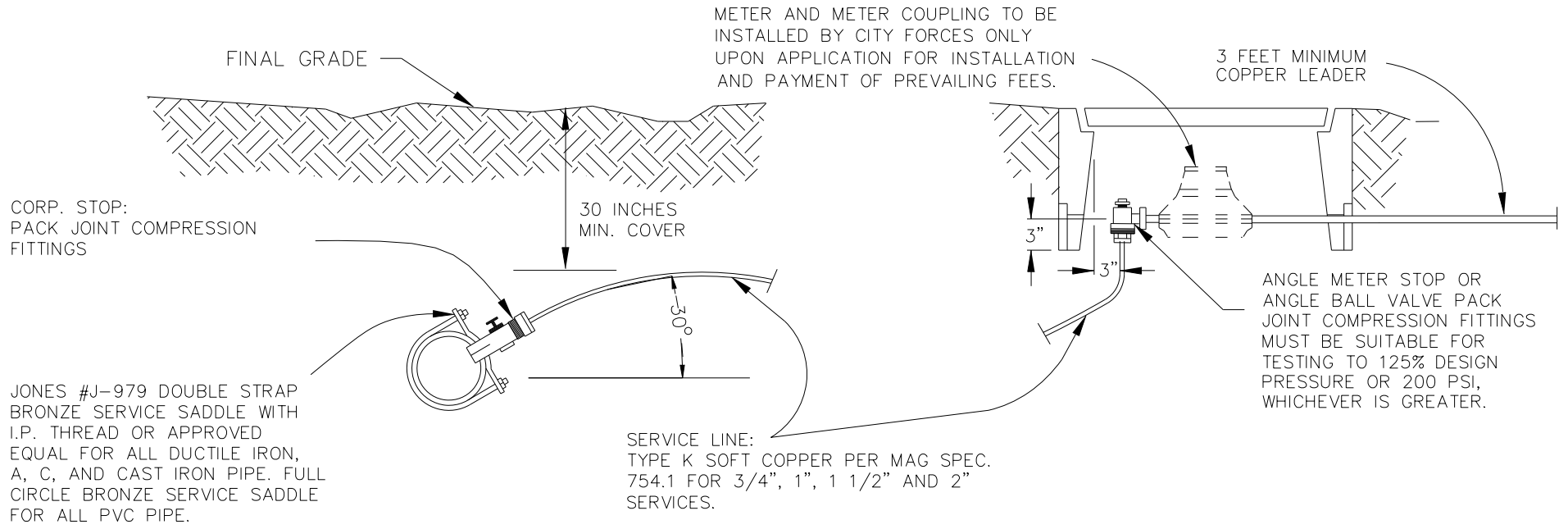

- NOTE:
1. All taps must be made using a service saddle.
 2. All service line sizes shall have the pack joint compression fittings for corp. stops and meter stops.
 3. Where a contractor is installing new water lines, all water service connections shall also be installed. The contractor's installation shall include the service saddle, corp. stop, service pipe, appurtenant fittings, meter stop, concrete meter box and box cover per M.A.G. Specifications.
 4. Copper service lines in the 3/4", 1", 1 1/2", and 2" sizes that cross streets will be one continuous piece. Only with written consent of Water & Wastewater Operations will joints be permitted under a road. When this occurs, pack joint fittings will be required; no soldered joints will be permitted.
 5. Authorized City of Scottsdale Water and Wastewater Operations personnel, or a City approved tapping contractor shall install the water service connections on existing mains.
 6. All services shall be set to final/curb grade prior to pressure testing. If meter stop is compromised during construction, or is affected as a result of grade change, it will be required to be replaced. Final landscape grade shall be set flush to top of the meter box.

DETAIL NO.
2330

**City of Scottsdale
Standard Details**

APPROVED BY:
**Scottsdale Standards &
Specifications Committee**

WATER SERVICE LINE CONNECTION

DETAIL NO.
2330

REVISED 3/11/94

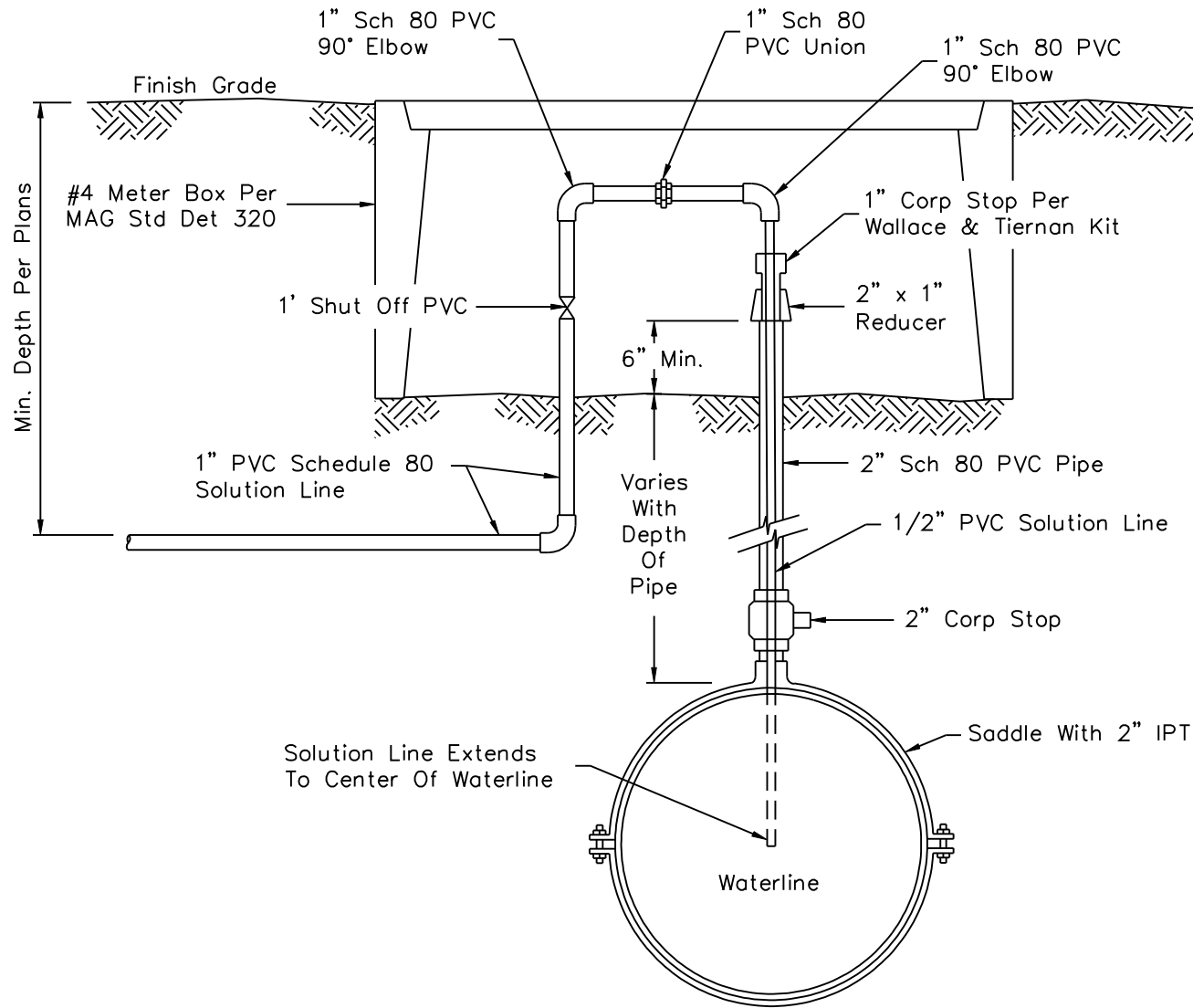

NOTE:

Specifications on all fittings shall exceed the maximum pressures of the system.

DETAIL NO.
2332

**City of Scottsdale
Standard Details**

APPROVED BY:
**Scottsdale Standards &
Specifications Committee**

**CHLORINE INJECTION TAP
FOR UNDERGROUND WATERLINES**

DETAIL NO.
2332

REVISED 1/4/93

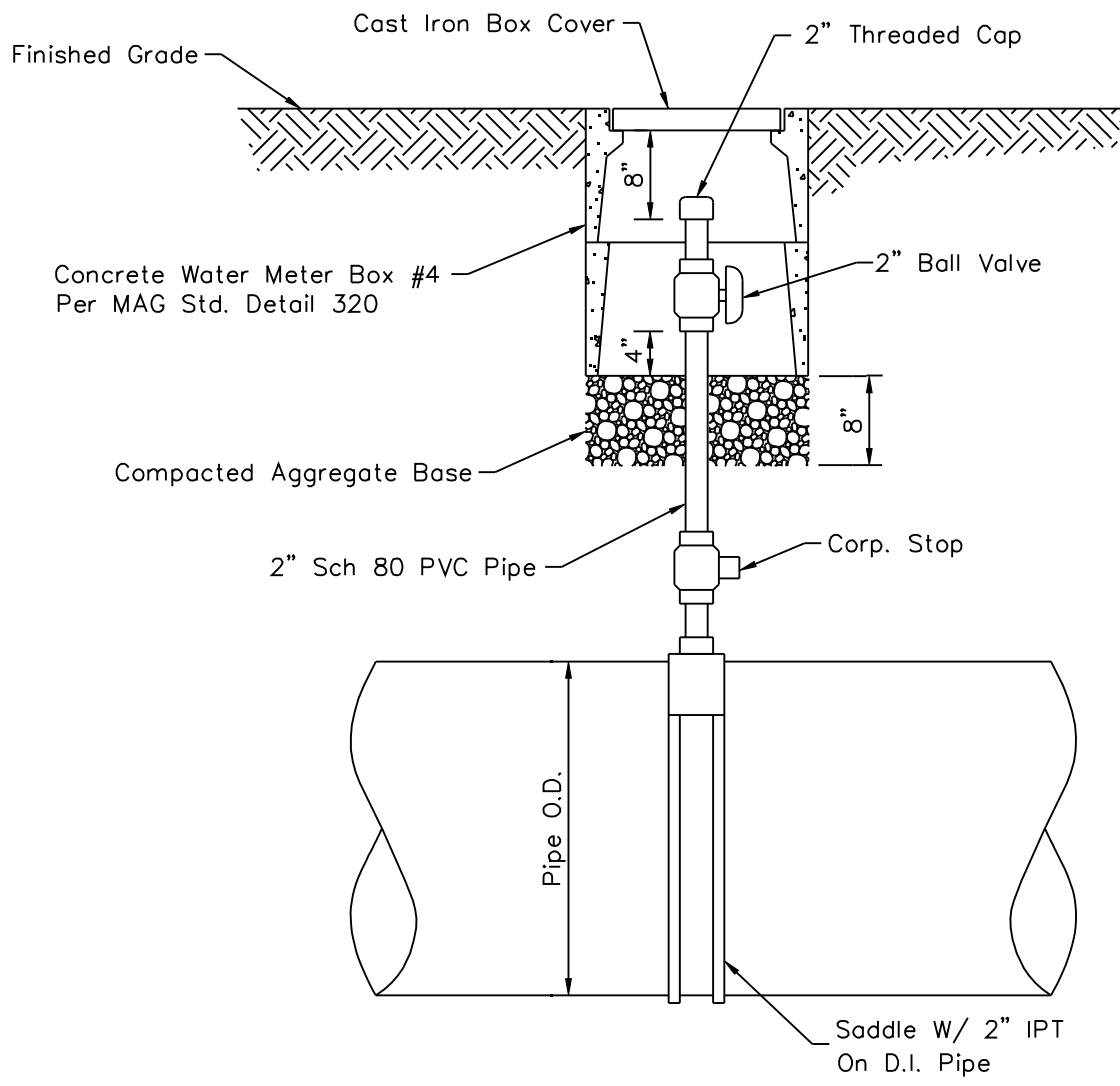

DETAIL NO.
2333

City of Scottsdale
Standard Details

APPROVED BY:
Scottsdale Standards & Specifications Committee

TAP FOR FUTURE CHLORINE INJECTION

DETAIL NO.
2333

REVISED 2/27/01

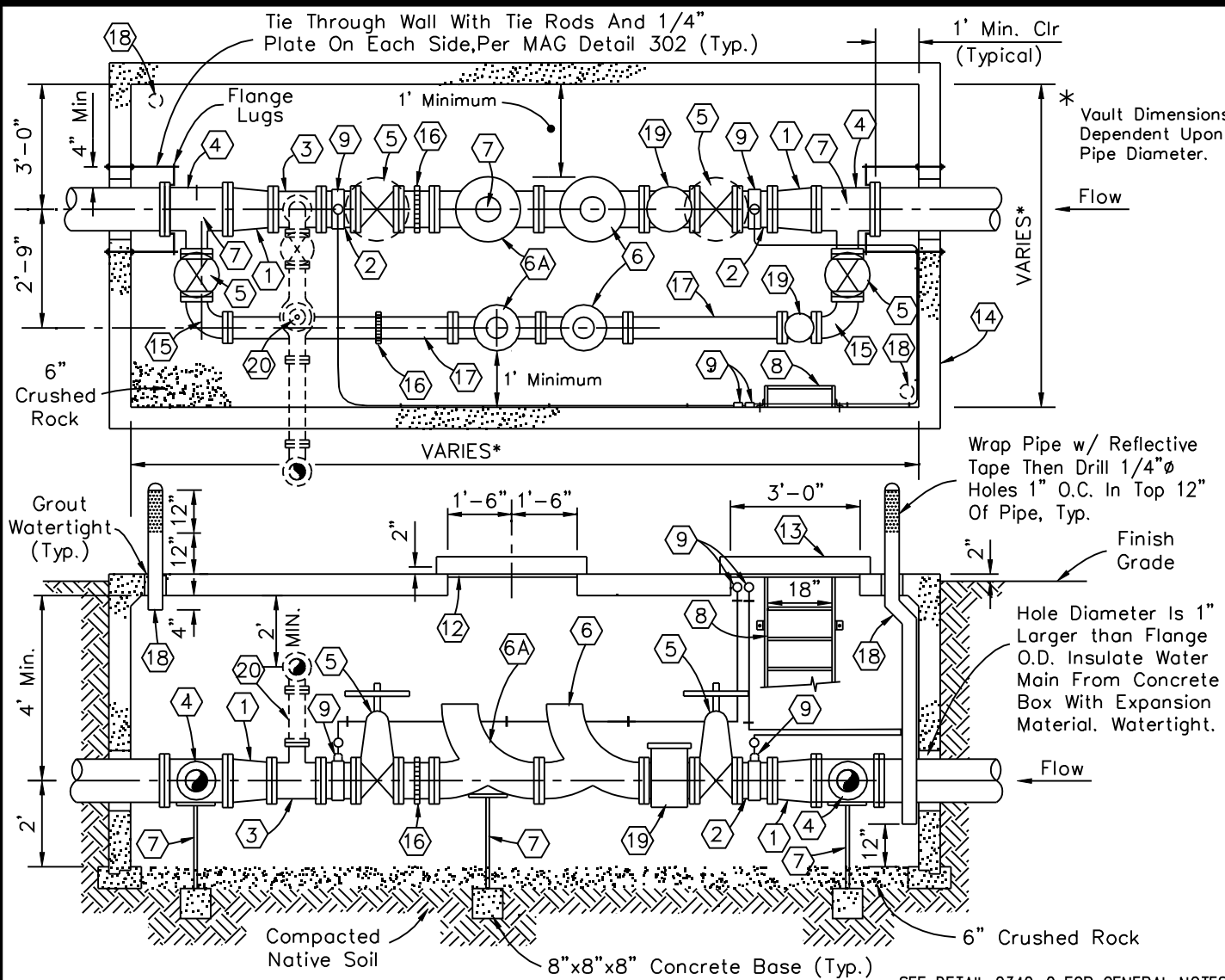

NOTES

- ① D.I.P. Flg Concentric Reducer
- ② D.I.P. Flg x Flg Spool Piece
- ③ D.I.P. Flg x Flg Tee. Install Only When Detail 2342-2 Is Used.
- ④ D.I.P. Flg Reducing Tee
- ⑤ Flg NRS Resilient Wedge Gate Valve, Inside Epoxy Coated, Low Zinc Stem w/ Wheel Handle
- ⑥ Flg PRV Bermad Model 723-20-V-I-U w/ Valve Position Indicator & Low Flow V-Port Plug And Must Have Stainless Steel Pilot Tubing, Or Approved Equal.
- ⑥A Flg PRV Bermad Model 723-20-V-I-U w/ Valve Or Approved Equal Will Be Installed When Pressure Differential Is 100 psi Or Greater.
- ⑦ 4" Dia Galv Adjustable Pipe Supports w/ 1" Adj. Rod And Nut On 8"x 8"x 8" Concrete Base.
- ⑧ Galv Access Ladder Bolted To Wall, 6" Stand Off.
- ⑨ Saddle With 1" Corp., 3/8" Brass Reducer, 3/8" 3/8" Brass Tee w/ Oil Filled 0-200 Pressure Gauge. Install 3/8" Stainless Tubing Strapped To Wall As Shown w/ Oil Filled Gauges Mounted At Access Door. Gages To Be Readable From Outside Vault.
- ⑫ For 8" Valves Or Larger Install Utility Vault Raised/ Adjustable Access Door, Model 3636, Or Approved Equal, Centered Over Main Valves For Removal.
- ⑬ Utility Vault Raised/Adjustable Steel Access Door For Inspection, Model 3636 Or Approved Equal. Place In Corner With Ladder.
- ⑭ Precast Concrete Water Utility Vault, Per MAG Std Det 321 & 345-1, Inside Dimensions Vary Depending On Pipe Size.
- ⑮ D.I.P. Flg 90° Elbow
- ⑯ Victaulic Coupling Or Approved Equal w/ All Thread Tie Rods.
- ⑰ D.I.P. Flg Pipe Spool
- ⑱ 4" Galv. Steel Vent Pipe With Cap. Strap Pipe To Wall. Install Vents In Unpaved Areas Only.
- ⑳ Basket Type Strainer
- ⑳ 4" Pressure Relief Bermad Model 730-I-U w/ Valve Position Indicator Or Approved Equal Required When Pressure Differential Meets Or Exceeds 100 PSI. See Detail 2342-2.

* Engineer to note direction of flow and pressure setting on the plans.

SEE DETAIL 2342-2 FOR GENERAL NOTES

DETAIL NO.
2342-1

**City of Scottsdale
Standard Details**

APPROVED BY:
**Scottsdale Standards &
Specifications Committee**

PRESSURE REDUCING VALVE

DETAIL NO.
2342-1

REVISED 2/27/01

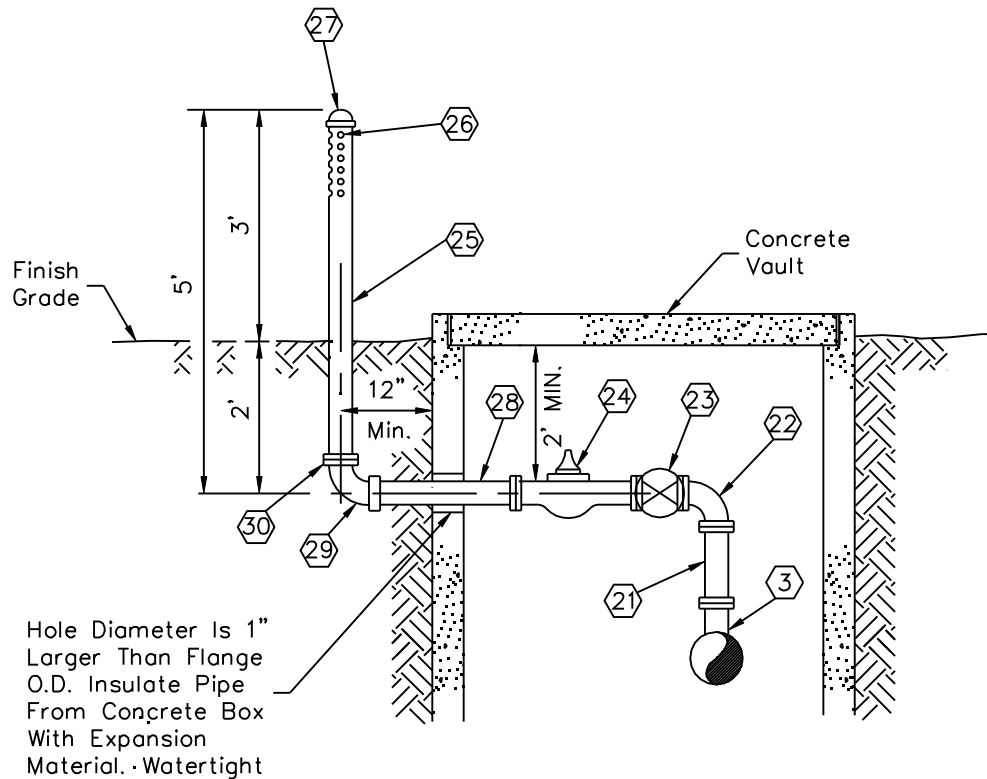

PRESSURE RELIEF OUTLET ASSEMBLY DETAIL

SEE NOTE 20 DETAIL 2342-1

NOTES

- 3 Flg x Flg Tee, See Detail 2342-1
- 21 4" Flg Connecting Piece
- 22 4" DIP Flg x Flg 90° Elbow, w/ Restrained Joints (Meg A Lug Or Approved Equal)
- 23 4" Flg NRS Resilient Wedge Gate Valve, Inside Epoxy Coated, Low Zinc Stem w/ Handwheel
- 24 4" Flg PRV Bermad Model 730-I-U Or Approved Equal, Epoxy Coated w/ Valve Position Indicator
- 25 4" SCH. 40 Steel Pipe (Painted Desert Beige)
- 26 6 Rows 2" O.C. Of 3-1"Ø Holes, 180° Spray Pattern
- 27 4" SCH 40 Steel Cap (Threaded)
- 28 4" Ductile Pipe Spool
- 29 4" DIP MJ x Flg 90° Elbow
- 30 Flanged Connection w/ Breakaway Bolts

GENERAL NOTES

1. All pipe and valves are to be rated per system pressure.
2. Pilot lines for all controls will be stainless steel tubing.
3. Stainless tubing bends will be uniform and made with a tubing bender.
4. Bypass line (small PRV) shall be 4" Min. D.I.P.
5. Airvents and relief outlet riser pipe shall not be located within 12 feet of an existing edge of pavement or within 2 feet of a barrier type curb or 2' back of sidewalk.

DETAIL NO.
2342-2

**City of Scottsdale
Standard Details**

APPROVED BY:
**Scottsdale Standards &
Specifications Committee**

PRESSURE REDUCING VALVE

DETAIL NO.
2342-2

REVISED 2/27/01

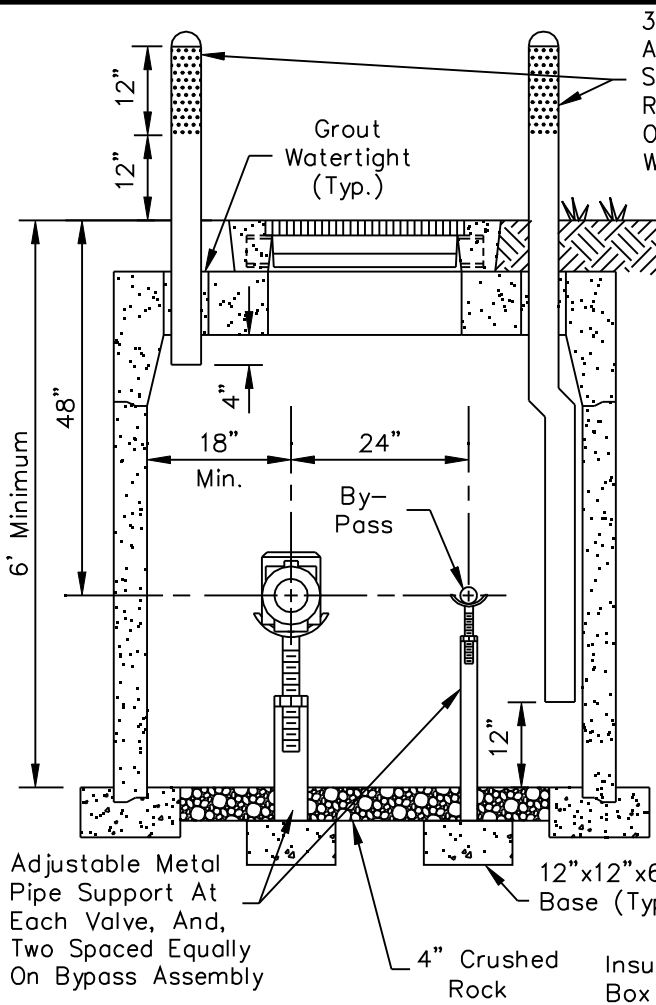

SECTION A-A

3" Dia. Sch 40 Steel Vent Pipe W/ Cap And Bracket as Manufactured By Blue Dot Steel Or Approved Equal. Wrap Pipe With Reflective Tape Then Drill 1/4"Ø Holes 1" O.C. In Top 12" Of Pipe. Strap Pipe To Wall. Install Vents In Unpaved Areas Only.

NOTE: Meter Vaults To Be Pre-Cast Concrete Unless Otherwise Approved By Water Operations. See MAG Std Detail 321 For Vault Construction.

VAULT DIMENSION TABLE			
MAIN SIZE	3"	4"	6"
(A)	8'-4"	10'-6"	12'-0"
(B)	4'-6"	5'-0"	5'-0"

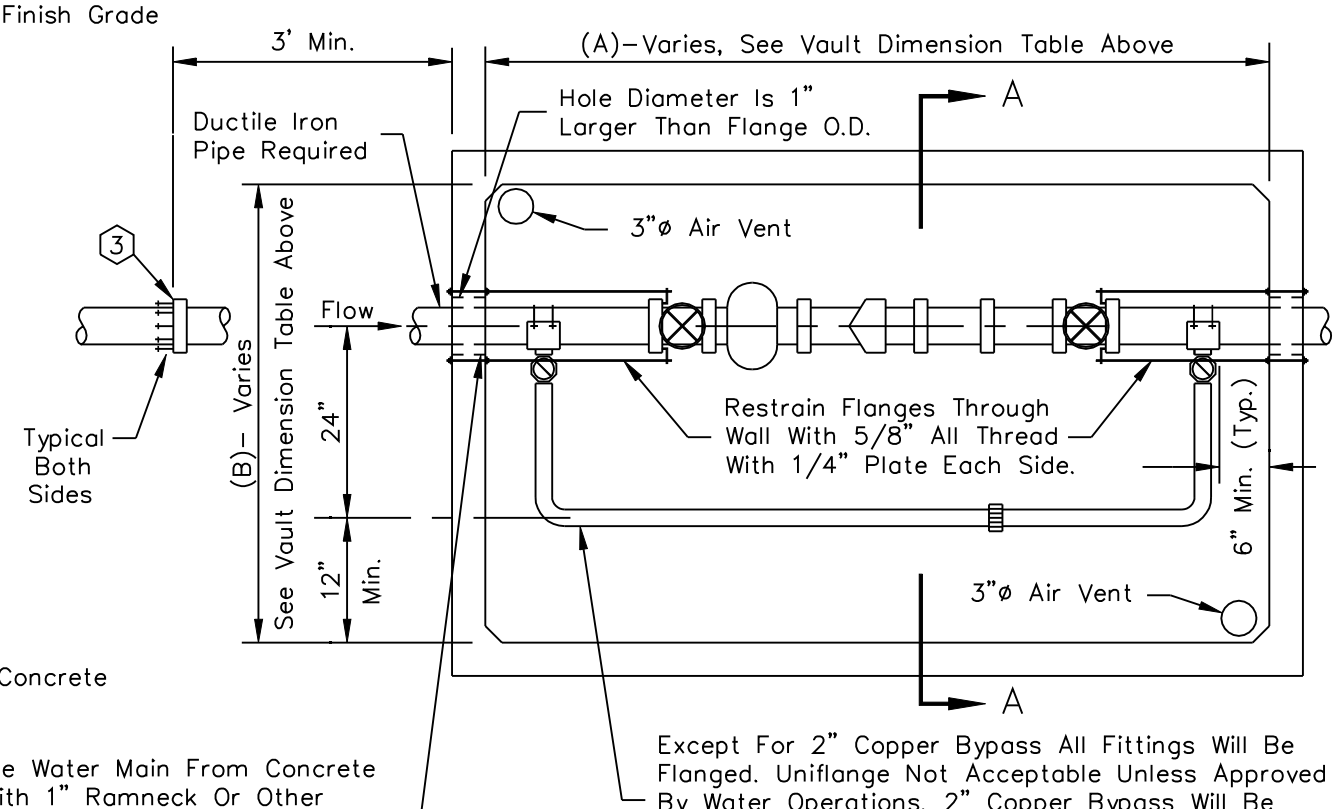

Insulate Water Main From Concrete Box With 1" Ramneck Or Other Expansion Material Approved By The Engineer. Grout Balance Of Opening Per MAG Specifications.

Except For 2" Copper Bypass All Fittings Will Be Flanged. Uniflange Not Acceptable Unless Approved By Water Operations. 2" Copper Bypass Will Be Joined With Silver Solder Except At 2" Corp Stop Which Will Be Pac Joint.

VAULT INSTALLATION

PLAN

SHEET 1 OF 2

DETAIL NO. 2345-1	City of Scottsdale Standard Details	APPROVED BY: Scottsdale Standards & Specifications Committee	3", 4", 6" WATER METER	DETAIL NO. 2345-1
-----------------------------	--	--	-------------------------------	-----------------------------

REVISED 2/27/01

For Vault Construction
See MAG Std Det 321

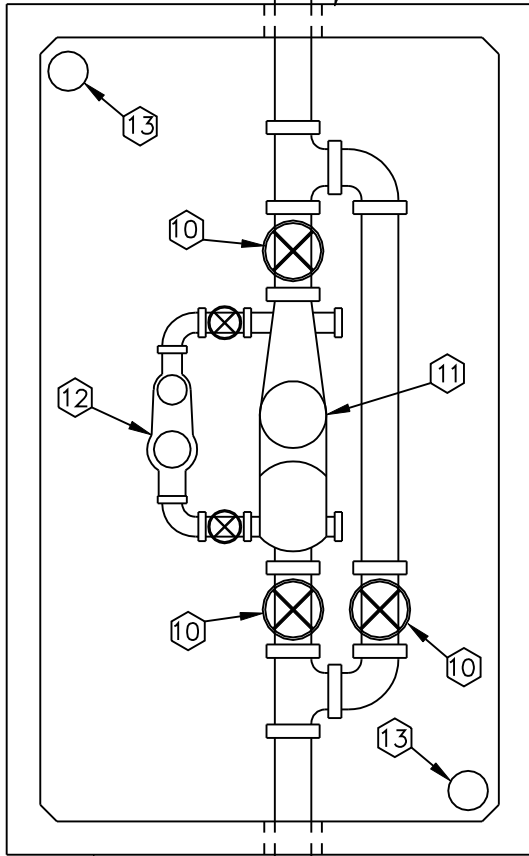

**COMBINATION DOMESTIC/
FIRE LINE METER**

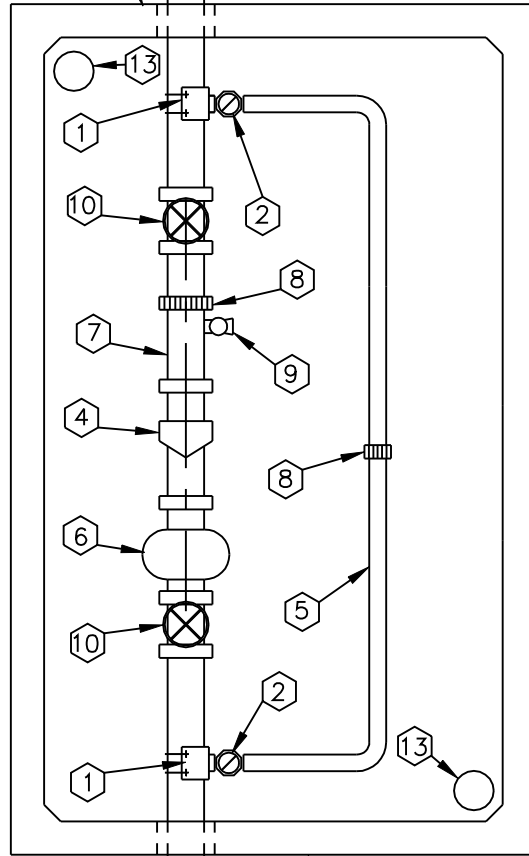

COMPOUND/TURBINE METER

Typical Both
Sides

KEY NOTES

- ① Double Strap All Bronze Service Saddle, Or Flanged x Flanged Tee With Flanged X Flanged Valve For Sizes 3" Or Larger.
- ② Corp. Stop, 2"(Ball Type), Or R.W. Gate Valve With Non-Rising Stem Handwheel Operator For 3" Or Larger.
- ③ Adaptor, Flanged To Mech. Joint For A.C.P.
- ④ Turbine (High Flow) Or Compound Meter, See Note 4 Below.
- ⑤ 2" Ridged Type "K" Copper By-Pass Line, 3" Or Larger To Be Ductile Iron. Not Less Than One Pipe Size Smaller Than Meter In Note 4.
- ⑥ Strainer, Supplied with Meter.
- ⑦ Flanged Spool, (3 Pipe Diameters In Length, Min.).
- ⑧ Provide Victaulic Coupling Or Approved Equal For All Lines 3" Or Larger.
- ⑨ 2" Threaded Outlet And Ball Valve. Not Needed If Vertical Test Valve Is Provided On Meter.
- ⑩ Resilient Wedge Gate Valve, Flanged, With Hand Wheel, Open Left, With Non-Rising Stem.
- ⑪ Turbine (High Flow) Or Compound Meter, See Note 4 Below.
- ⑫ 2" Turbine Meter: Sensus "W-160" Or Hersey "MHR" Or Neptune Trident Turbine.
- ⑬ 3"Ø Air Vent, See Sheet 1 Of 2.

NOTES

1. For Larger Meters Special Vault Design Is Required.
2. Use Of Remote Reading Device At Option Of Utility.
3. An Approved Backflow Prevention Assembly Shall Be Required Downstream Of The Water Meter. Contact Water Resources, Backflow Prevention For Specific Information.
4. Meter To Be Provided By City Upon Payment Of Fees.

SHEET 2 OF 2

DETAIL NO.
2345-2

**City of Scottsdale
Standard Details**

APPROVED BY:
**Scottsdale Standards &
Specifications Committee**

3, 4", 6" WATER METER

DETAIL NO.
2345-2

REVISED 4/25/07

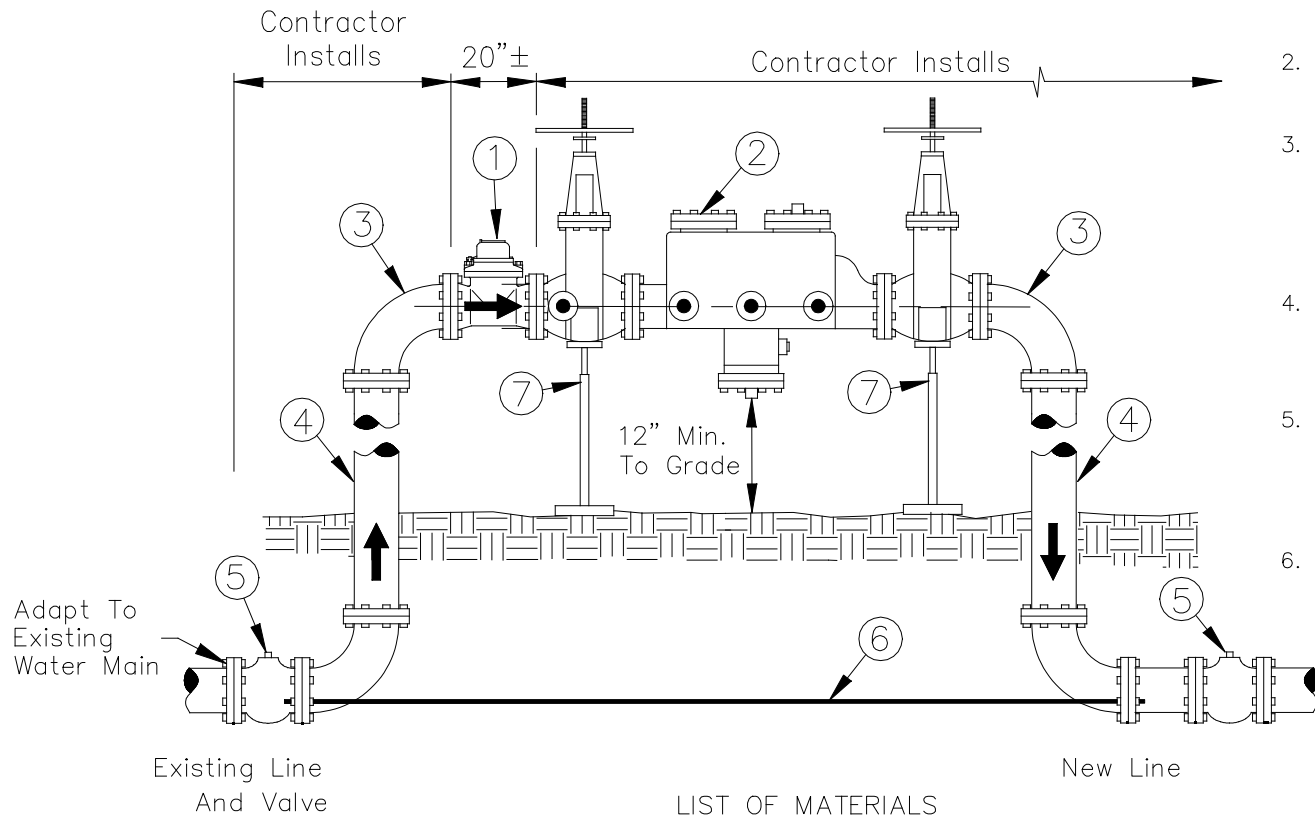

GENERAL NOTES

1. Contractor to supply and install above ground piping and fittings to accommodate 3" meter, backflow preventer and 2 - 90° ells.
2. Contractor to remove piping and fittings after acceptance of new water main and complete connection as per MAG Standards.
3. Approvals for backflow assemblies must have Seal Approval from the American Society of Sanitation Engineers. Backflow assemblies installed on fire suppression systems must also have approval from Underwriters Laboratories and/or Factory Mutual Research Corporation.
4. Any water line that is greater than 300 feet will require a temporary construction meter. Water lines less than 300 feet will not require a construction meter but will still be subject to bacterial testing.
5. City Inspector to determine readiness for meter prior to contacting Water Resources for meter setting. Contractor to supply transmittal number to City Inspector. City Inspector to notify the Water Resources Department when meter is ready for installation.
6. Reduced pressure principle backflow assemblies must be tested by a certified tester after installation, that is recognized by the City of Scottsdale.

LIST OF MATERIALS

- | | |
|--|---|
| <ul style="list-style-type: none"> ① 3" Turbine Construction Meter With 3" Flanges, Supplied By City. ② 3" Approved Reduced Pressure Principle Backflow Prevention Assembly, Supplied By Contractor. ③ 3" Flanged Ductile Iron 90° Ell, Supplied By Contractor. ④ 3" Ductile Iron Spool. | <ul style="list-style-type: none"> ⑤ Line valves shall be within a 20' maximum distance upstream and downstream of flow meter or as approved by COS, and shall remain in-place after removal of temporary meter. ⑥ 3/4"Ø zinc coated threaded rod. ⑦ Adjustable Metal Pipe Support (Required). |
|--|---|

DETAIL NO. 2346	City of Scottsdale Standard Details	APPROVED BY: Scottsdale Standards & Specifications Committee	TEMPORARY CONSTRUCTION METER	DETAIL NO. 2346
---------------------------	--	--	-------------------------------------	---------------------------

REVISED 4/17/09

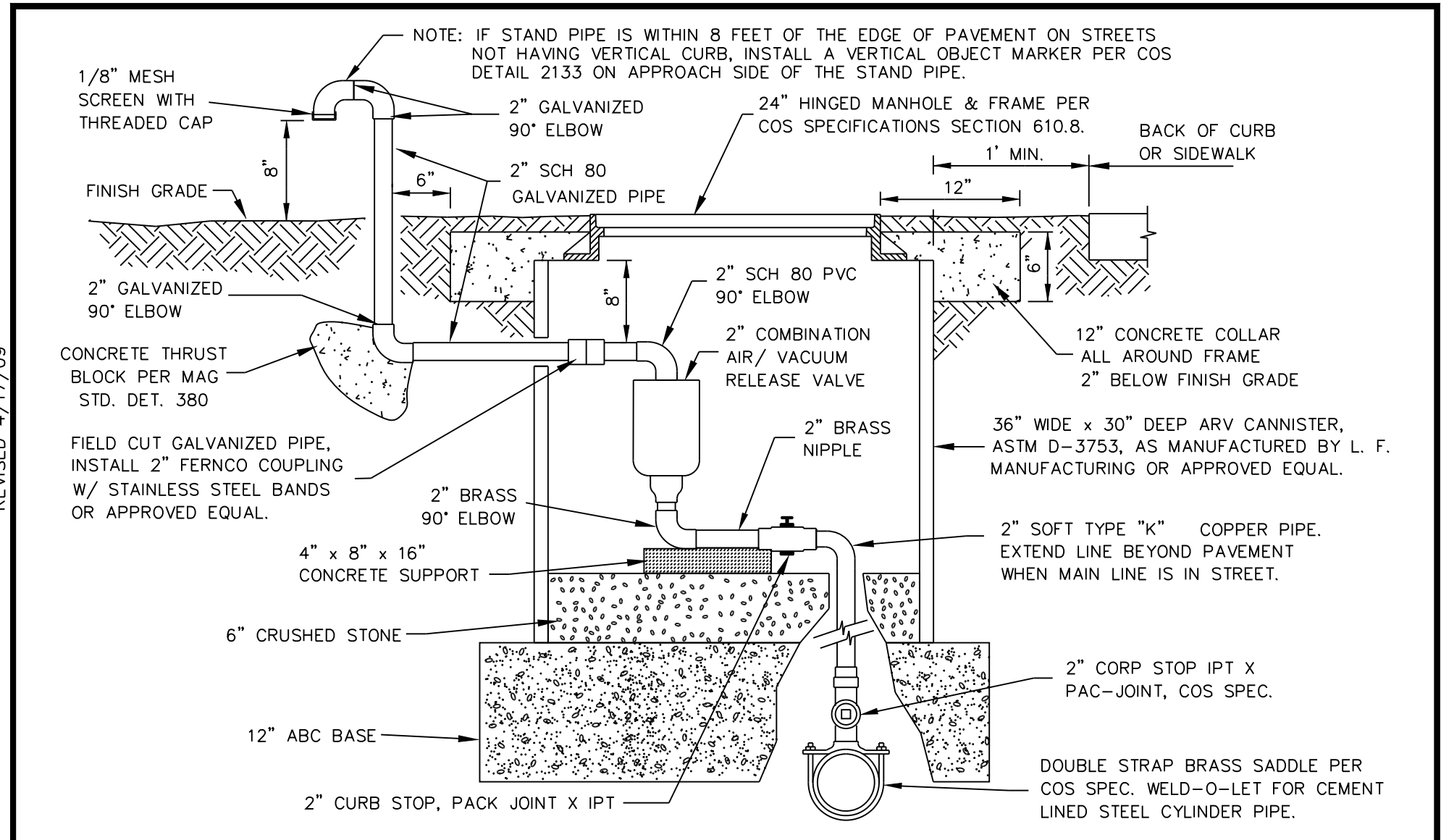

DETAIL NO. 2348

City of Scottsdale Standard Details

APPROVED BY: Scottsdale Standards & Specifications Committee

2" AIR/VACUUM RELEASE VALVE

DETAIL NO. 2348

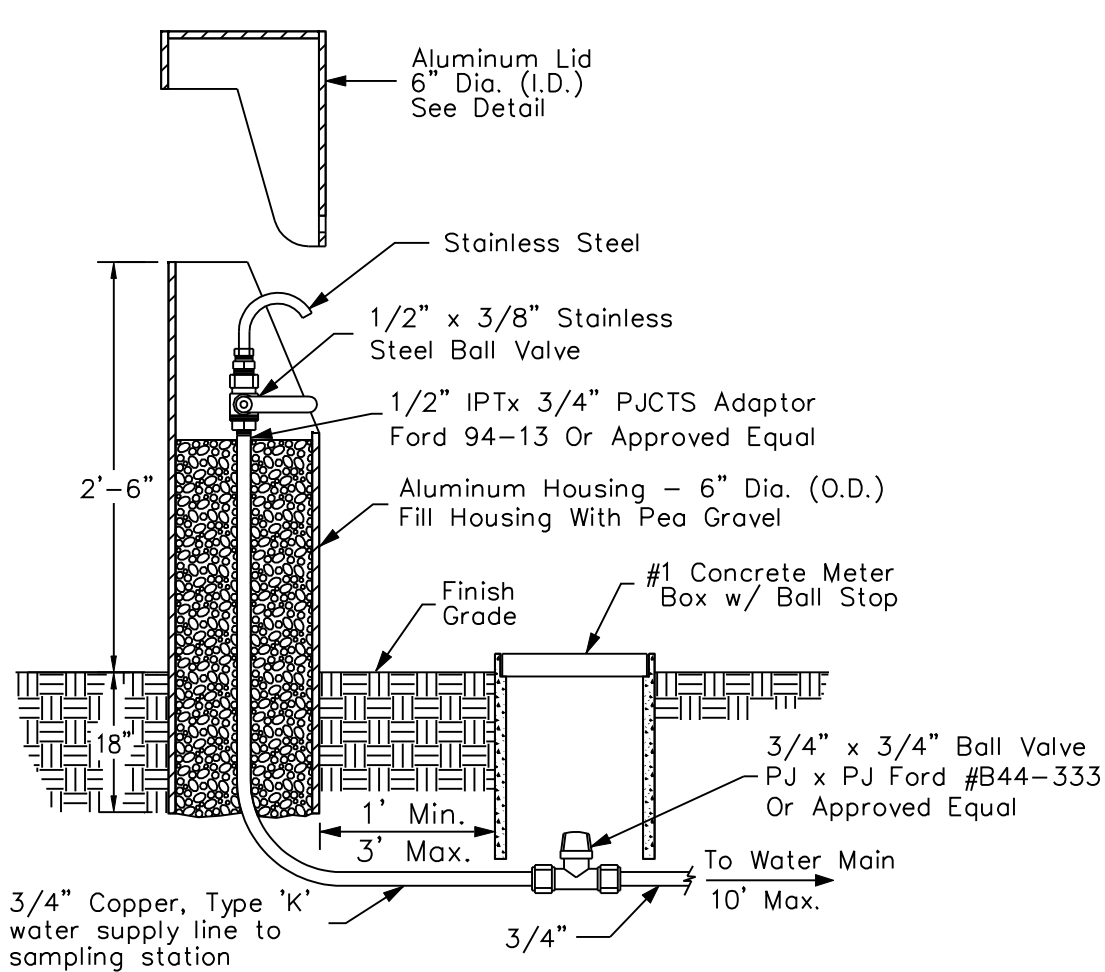

TYPICAL INSTALLATION

N.T.S.

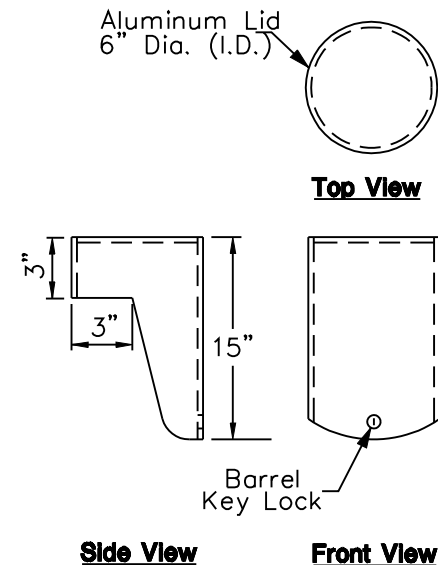

LID DETAILS

N.T.S.

NOTES:

1. Water Quality Sampling Station to be Koralean or approved equal.
2. Keys to locks shall be delivered to City of Scottsdale Water Quality Department upon acceptance.

DETAIL NO.
2349

**City of Scottsdale
Standard Details**

APPROVED BY:
**Scottsdale Standards &
Specifications Committee**

WATER QUALITY SAMPLING STATION

DETAIL NO.
2349

REVISED 5/5/04

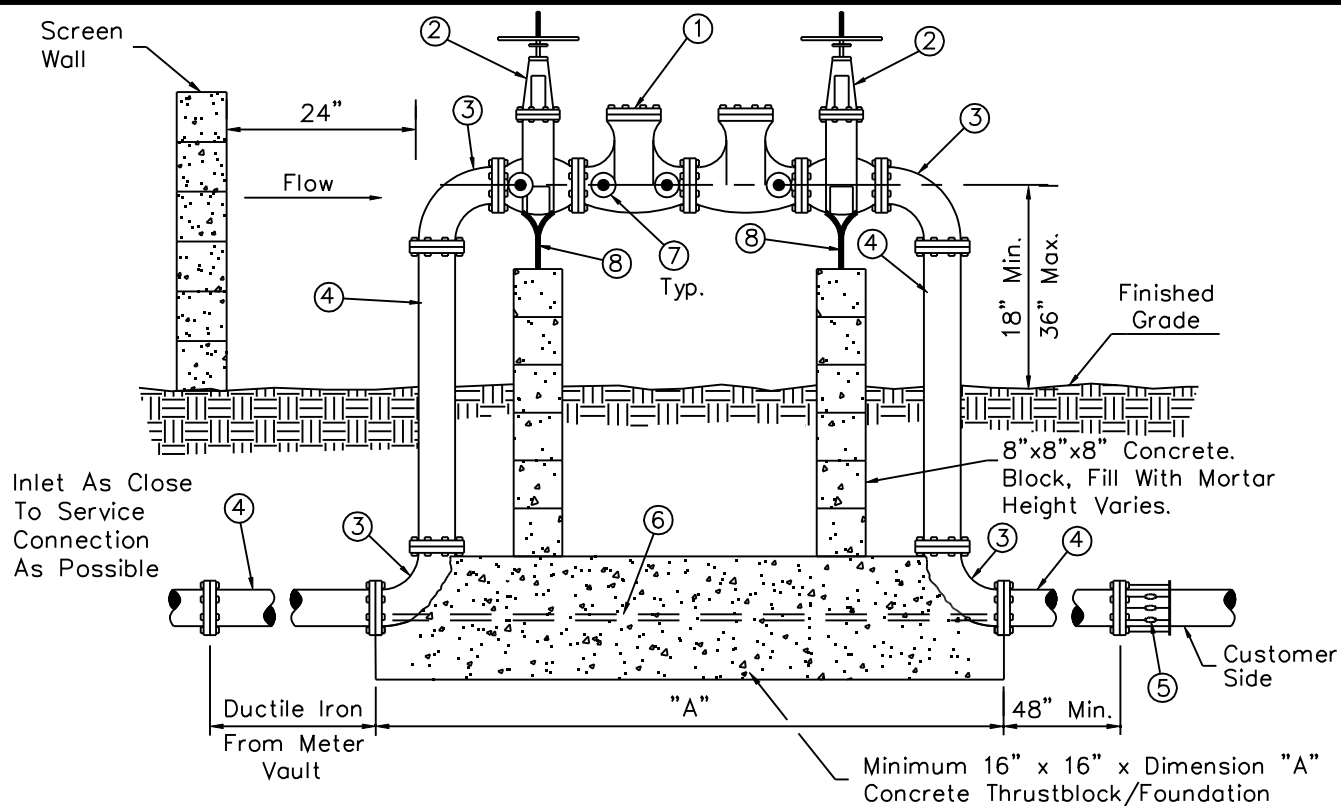

GENERAL NOTES

1. Backflow assemblies must be tested by a certified tester that is recognized by the City of Scottsdale.
2. Backflow preventers shall be painted light tan or a color to match the building. Do not paint the name plate or any brass parts on the assembly.
3. For backflow preventers requiring guard posts see Detail 2356. Backflow preventers enclosed by screening shall maintain a 24 inch clearance around the assembly.
4. Finished grade underneath the backflow preventer shall be at 95% compaction.
5. Backflow preventers on fire lines may require tamper switches on the shut off valves. Contact City Of Scottsdale Plan Review, Fire Dept.
6. Call for underground inspection before backfilling trench.
7. Vertical installations of assemblies on fire sprinkler systems are allowed using assemblies approved for use in the vertical position on fire systems.
8. Approvals for backflow assemblies must have Seal Approval from the American Society of Sanitation Engineers. Backflow assemblies installed on fire suppression systems must also have approval from Underwriters Laboratories and/or Factory Mutual Research Corporation.

LIST OF MATERIALS

- | | |
|--|--|
| <p>① Approved double check valve backflow prevention assembly.</p> <p>② Resilient seated gate valve.
O.S. & Y. (fire line connection)
N.R.S. (non fire line)</p> <p>③ 90° ell, Flanged D.I.P. 3" thru 10", Mega Lug or approved equal may be used on underground joints.</p> <p>④ Pipe spool, Flanged D.I.P. 3" thru 10", Mega Lug or approved equal may be used on underground joints.</p> <p>⑤ Flanged adapter (when required)</p> | <p>⑥ 3/4" zinc coated threaded rod, (5/8" rod on 3" to 4" sizes), bolt to flanges as shown, typical both sides.</p> <p>⑦ Test cocks with brass plugs or adaptors with caps installed. (4 required)</p> <p>⑧ Adjustable metal pipe supports and concrete block supports with 1" adjusting rod and nut on assemblies 4" and larger. Install above grade.</p> |
|--|--|

DETAIL NO.
2351

**City of Scottsdale
Standard Details**

APPROVED BY:
**Scottsdale Standards &
Specifications Committee**

**DOUBLE CHECK VALVE BACKFLOW PREVENTION ASSEMBLY
FOR ASSEMBLIES 3 INCHES THRU 10 INCHES**

DETAIL NO.
2351

REVISED 1/19/12

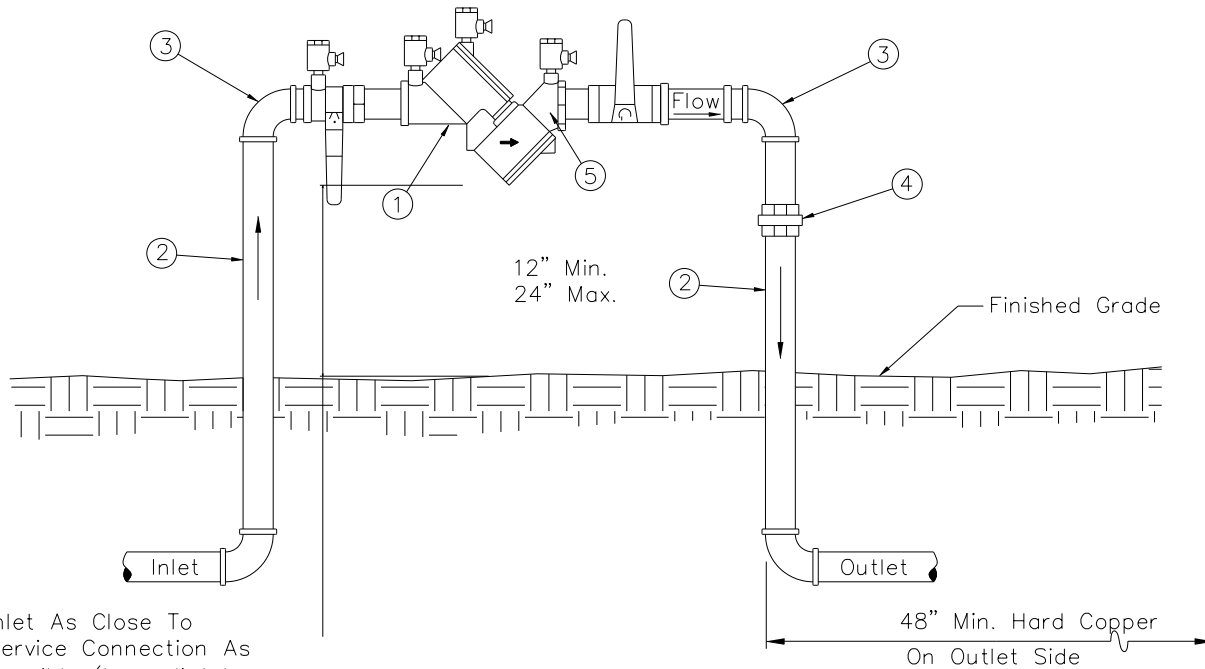

Inlet As Close To Service Connection As Possible (Immediately After Water Meter).
Hard Copper On Inlet Side.

LIST OF MATERIALS

- ① Approved double check valve backflow prevention assembly, ball valves included.
- ② Pipe spool, type "L" hard copper, 3/4" thru 2 1/2".
- ③ 90° ell, copper, 3/4" thru 2 1/2".
- ④ Pipe union, brass or copper.
- ⑤ Test cocks with brass plugs or adaptors with caps installed. (4 required)

GENERAL NOTES

- 1. Backflow assemblies must be tested by a certified tester that is recognized by the City of Scottsdale.
- 2. Copper fittings shall be connected with lead free solder joints or approved equal.
- 3. Finished grade underneath the backflow preventer shall be at 95% compaction.
- 4. All nipples to be copper or brass.
- 5. Inlet / outlet piping must be type "k" hard copper.
- 6. Call for underground inspection before backfilling trench.
- 7. Vertical installations of assemblies on fire sprinkler systems are allowed using assemblies approved for use in the vertical position on fire systems.
- 8. Approvals for backflow assemblies must have Seal Approval from the American Society of Sanitation Engineers. Backflow assemblies installed on fire suppression systems must also have approval from Underwriters Laboratories and/or Factory Mutual Research Corporation.

DETAIL NO.
2352

**City of Scottsdale
Standard Details**

APPROVED BY:
**Scottsdale Standards &
Specifications Committee**

**DOUBLE CHECK VALVE BACKFLOW PREVENTION ASSEMBLY
FOR ASSEMBLIES 3/4 INCH THRU 2 1/2 INCHES**

DETAIL NO.
2352

REVISED 5/05/04

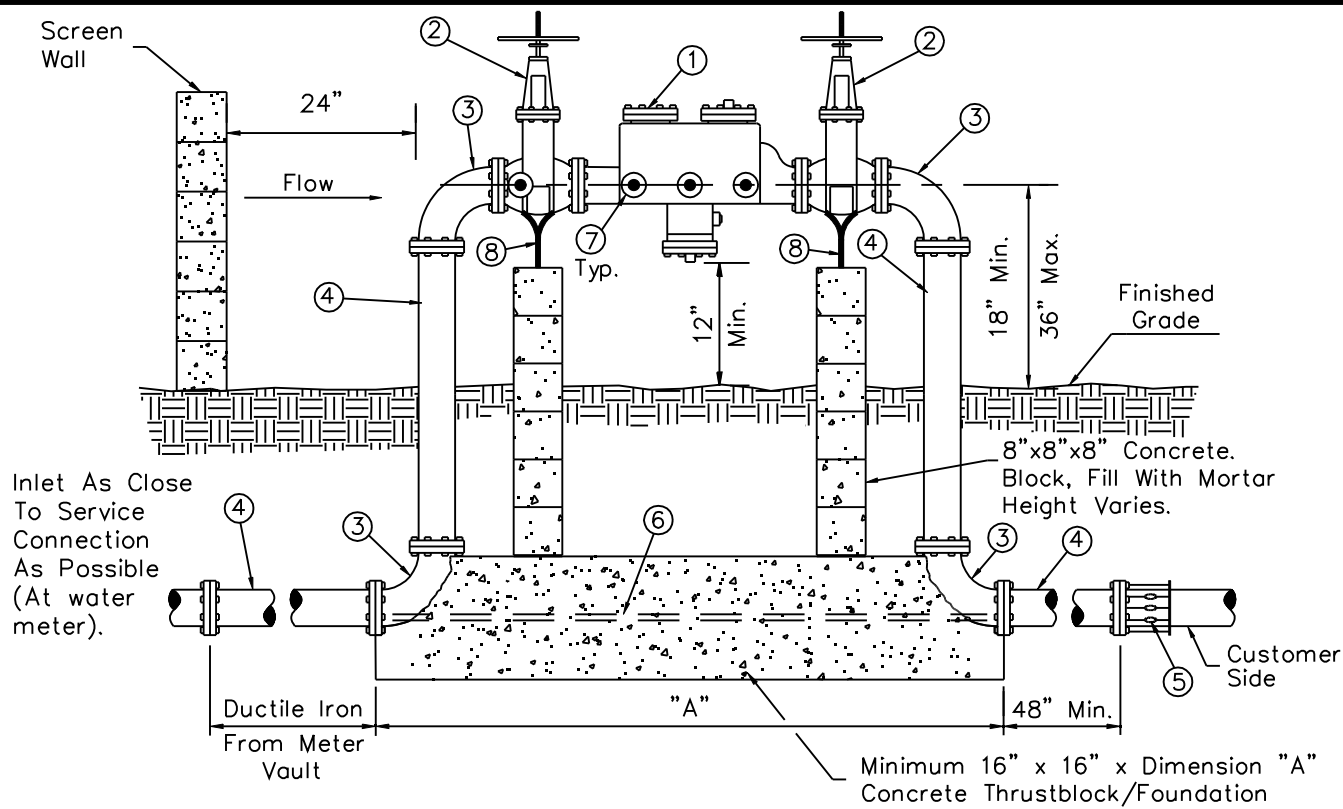

GENERAL NOTES

1. Backflow assemblies must be tested by a certified tester that is recognized by the City of Scottsdale.
2. Backflow preventers shall be painted light tan or a color to match the building. Do not paint the name plate or any brass parts on the assembly.
3. For backflow preventers requiring guard posts see Detail 2356. Backflow preventers enclosed by screening shall maintain a 24 inch clearance around the assembly.
4. Finished grade underneath the backflow preventer shall be at 95% compaction.
5. Backflow preventers on fire lines may require tamper switches on the shut off valves. Contact City Of Scottsdale Plan Review, Fire Dept.
6. Call for underground inspection before backfilling trench.
7. Approvals for backflow assemblies must have Seal Approval from the American Society of Sanitation Engineers. Backflow assemblies installed on fire suppression systems must also have approval from Underwriters Laboratories and/or Factory Mutual Research Corporation.

LIST OF MATERIALS

- | | |
|--|---|
| <ol style="list-style-type: none"> ① Approved reduced pressure principle backflow prevention assembly. ② Resilient seated gate valve. O.S. & Y. (fire line connection). N.R.S. (non fire line) ③ 90° ell. Flanged D.I.P. 3" thru 10", Mega Lug or approved equal may be used on underground joints. ④ Pipe spool. Flanged D.I.P. 3" thru 10", Mega Lug or approved equal may be used on underground joints. ⑤ Flanged adapter (when required) | <ol style="list-style-type: none"> ⑥ 3/4" zinc coated threaded rod, (5/8" rod on 3" to 4" sizes), bolt to flanges as shown, typical both sides. ⑦ Test cocks with brass plugs or adaptors with caps installed. (4 required) ⑧ Adjustable metal pipe supports and concrete block supports with 1" adjusting rod and nut on assemblies 4" and larger. Install above grade. |
|--|---|

DETAIL NO. 2353	City of Scottsdale Standard Details	APPROVED BY: Scottsdale Standards & Specifications Committee	REDUCED PRESSURE PRINCIPLE BACKFLOW PREVENTION ASSEMBLY FOR ASSEMBLIES 3 INCHES THRU 10 INCHES	DETAIL NO. 2353
---------------------------	--	--	---	---------------------------

REVISED 1/19/12

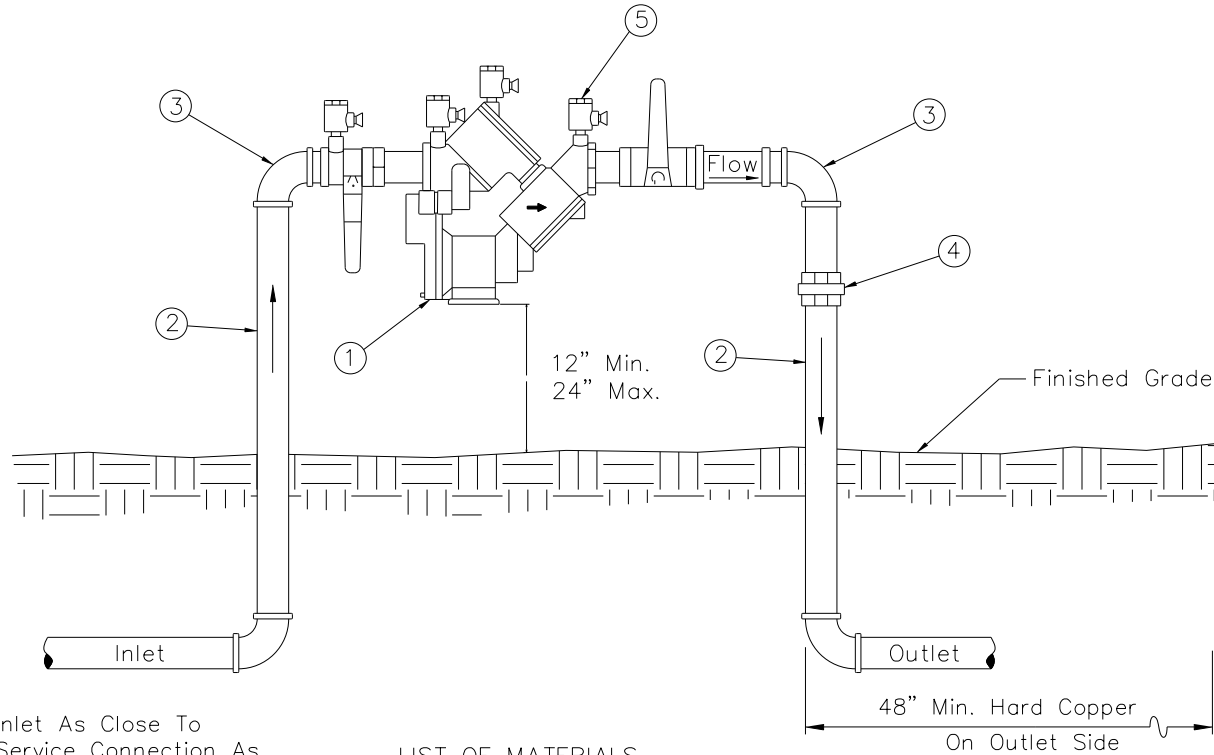

Inlet As Close To Service Connection As Possible (Immediately After Water Meter).
Hard Copper On Inlet Side.

LIST OF MATERIALS

- ① Approved reduced pressure principle backflow prevention assembly, ball valves included.
- ② Pipe spool, type "L" hard copper, 3/4" thru 2 1/2".
- ③ 90° ell, copper, 3/4" thru 2 1/2".
- ④ Pipe union, brass or copper.
- ⑤ Test cocks with brass plugs or adaptors with caps installed. (4 Required)

GENERAL NOTES

- 1. Backflow assemblies must be tested by a certified tester that is recognized by the City of Scottsdale.
- 2. Copper fittings shall be connected with lead free solder joints or approved equal.
- 3. Finished grade underneath the backflow preventer shall be at 95% compaction.
- 4. All nipples to be copper or brass.
- 5. Inlet / outlet piping must be type "K" hard copper.
- 6. Call for underground inspection before backfilling trench.
- 7. Approvals for backflow assemblies must have Seal Approval from the American Society of Sanitation Engineers. Backflow assemblies installed on fire suppression systems must also have approval from Underwriters Laboratories and/or Factory Mutual Research Corporation.

DETAIL NO.
2354

**City of Scottsdale
Standard Details**

APPROVED BY:
**Scottsdale Standards &
Specifications Committee**

**REDUCED PRESSURE PRINCIPLE BACKFLOW PREVENTION
ASSEMBLY FOR ASSEMBLIES 3/4 INCH THRU 2 1/2 INCHES**

DETAIL NO.
2354

REVISED 1/19/12

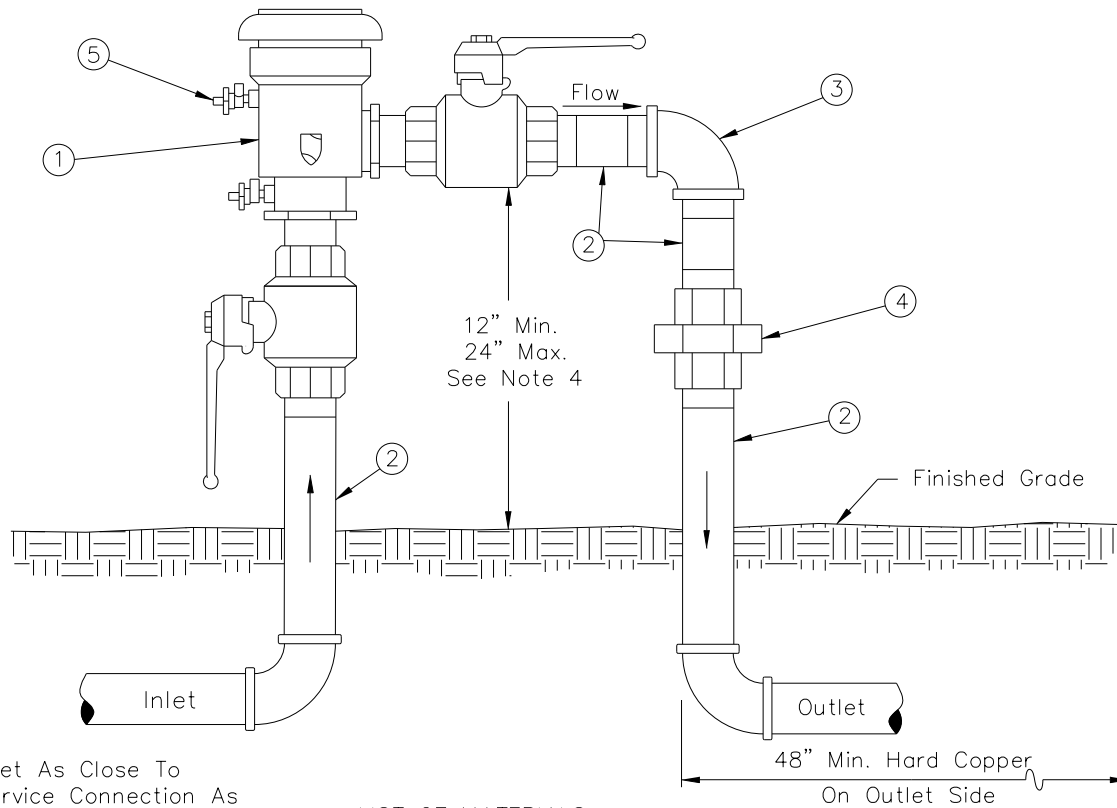

Inlet As Close To Service Connection As Possible (Immediately After Water Meter).
Hard Copper On Inlet Side.

LIST OF MATERIALS

- ① Approved pressure vacuum breaker assembly, ball valves included.
- ② Pipe spool, type "L" hard copper, 1/2" thru 2".
- ③ 90° ell, copper, 1/2" thru 2".
- ④ Pipe union, brass or copper.
- ⑤ Test cocks with brass plugs or adaptors with caps installed. (2 required)

GENERAL NOTES

- 1. Backflow assemblies must be tested by a certified tester that is recognized by the City of Scottsdale.
- 2. Pressure vacuum breakers must be installed at least 12" above all downstream piping.
- 3. If this distance exceeds 24 inches, a reduced pressure principle backflow prevention assembly must be utilized. See Detail 2354.
- 4. Copper fittings shall be connected with lead free solder joints or approved equal.
- 5. Finished grade underneath the backflow preventer shall be at 95% compaction.
- 6. All nipples to be copper or brass.
- 7. Inlet / Outlet piping must be type "K" hard copper.
- 8. Call for underground inspection before backfilling trench.
- 9. Approvals for backflow assemblies must have Seal Approval from the American Society of Sanitation Engineers.

DETAIL NO.
2355

City of Scottsdale
Standard Details

APPROVED BY:
Scottsdale Standards & Specifications Committee

PRESSURE VACUUM BREAKER ASSEMBLY
FOR ASSEMBLIES 1/2 INCH THRU 2 INCHES

DETAIL NO.
2355

REVISED 2/09/99

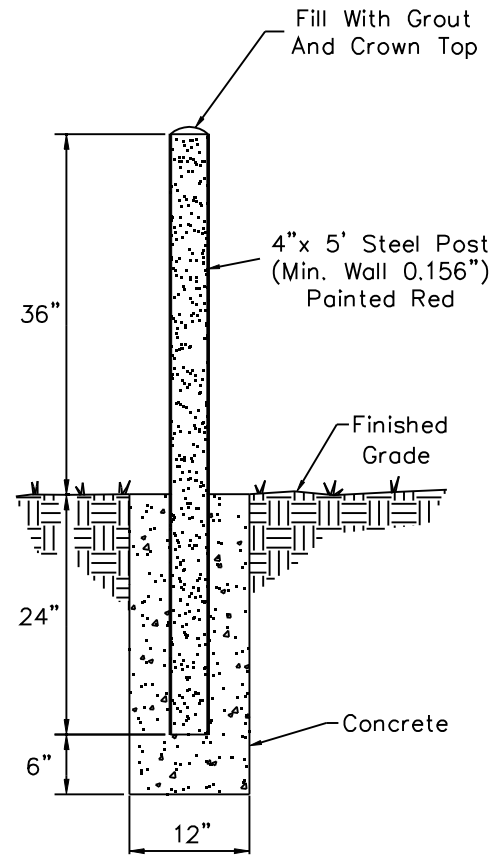
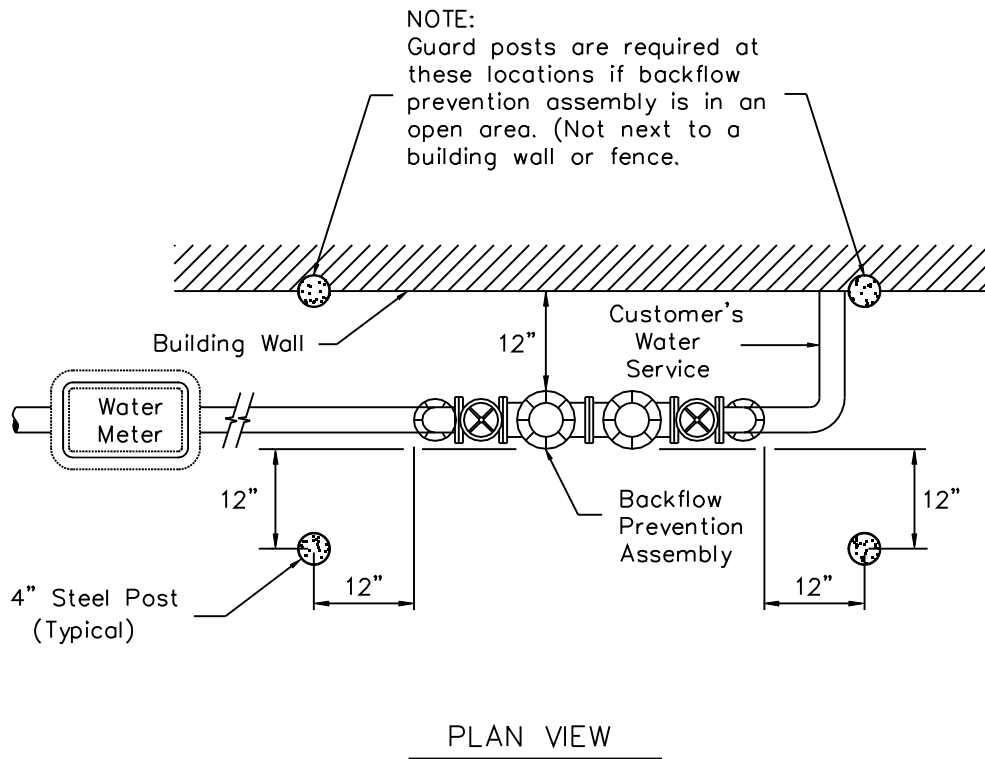

DETAIL NO.
2356

City of Scottsdale
Standard Details

APPROVED BY:
Scottsdale Standards & Specifications Committee

GUARD POSTS FOR BACKFLOW PREVENTION ASSEMBLIES

DETAIL NO.
2356

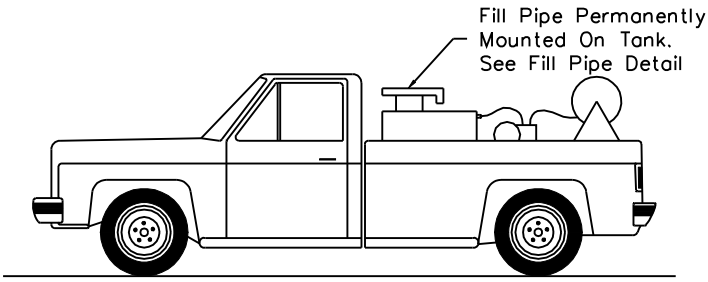

Fill Pipe Permanently Mounted On Tank. See Fill Pipe Detail

PESTICIDE APPLICATOR TRUCK

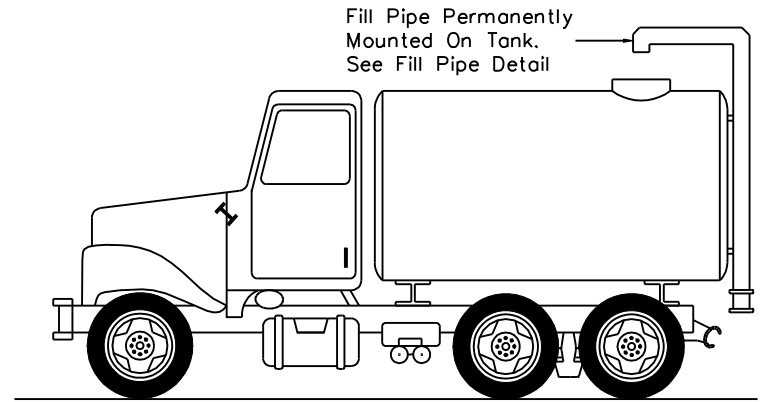

Fill Pipe Permanently Mounted On Tank. See Fill Pipe Detail

WATER TRUCK

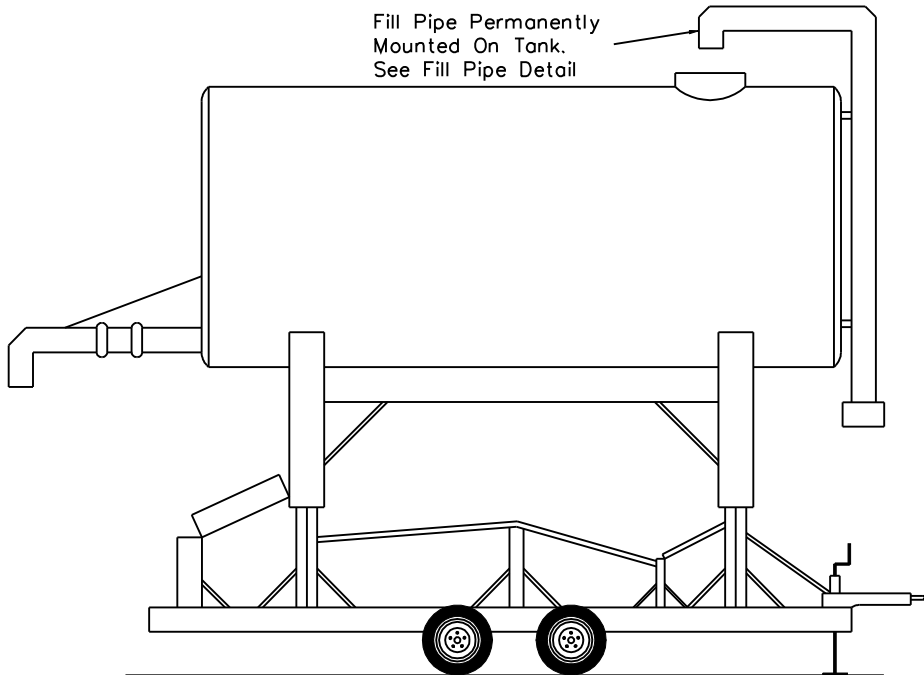

Fill Pipe Permanently Mounted On Tank. See Fill Pipe Detail

ELEVATED TANK

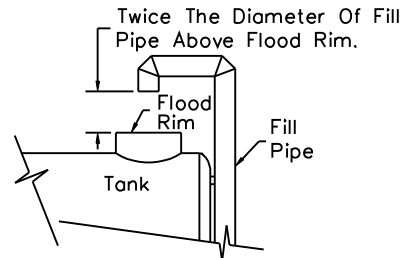

Twice The Diameter Of Fill Pipe Above Flood Rim.

FILL PIPE DETAIL

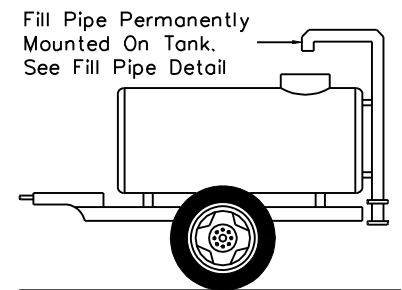

Fill Pipe Permanently Mounted On Tank. See Fill Pipe Detail

WATER WAGON

DETAIL NO.
2357

**City of Scottsdale
Standard Details**

APPROVED BY:
**Scottsdale Standards &
Specifications Committee**

**FILL PIPE DETAILS FOR PORTABLE TANKS WITH
AIR GAP SEPARATION**

DETAIL NO.
2357

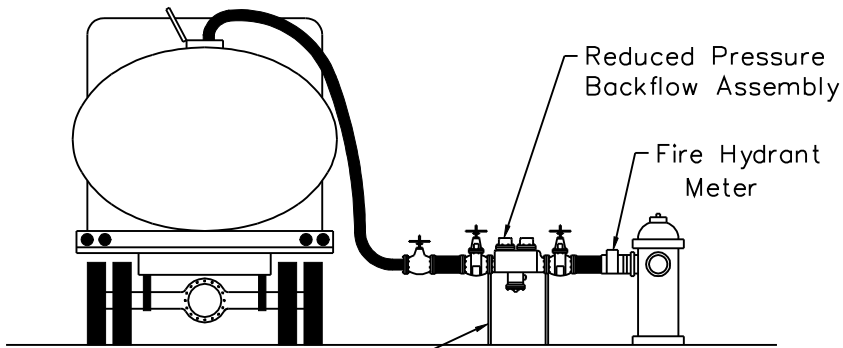

Supports Required

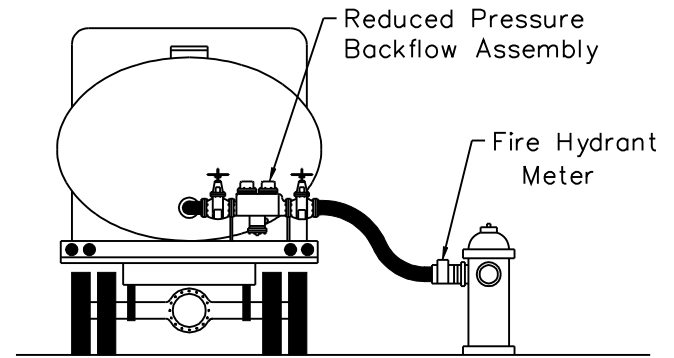

TANK TRUCKS

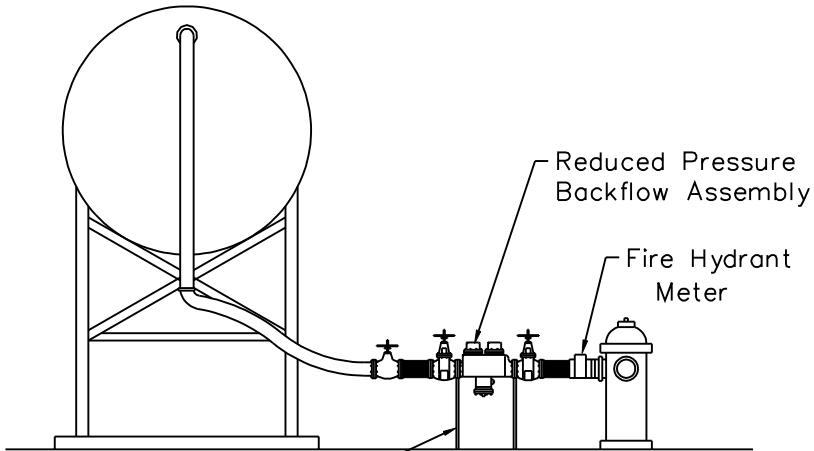

Supports Required

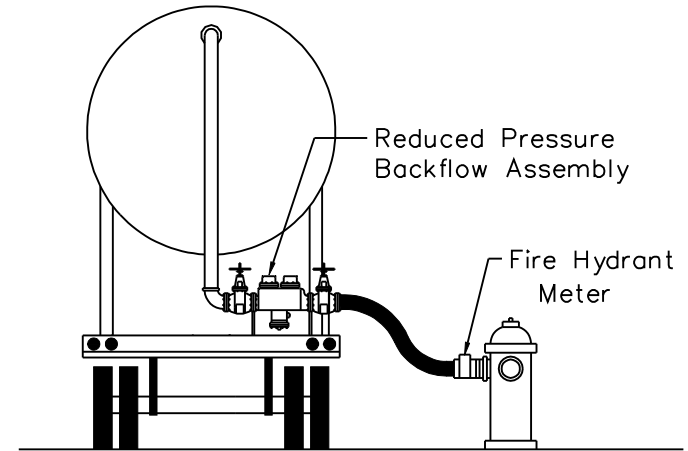

ELEVATED TANKS

DETAIL NO.
2358

**City of Scottsdale
Standard Details**

APPROVED BY:
**Scottsdale Standards &
Specifications Committee**

**BACKFLOW PREVENTION METHOD FOR PORTABLE TANKS
WITH NO AIR GAP SEPARATION**

DETAIL NO.
2358

REVISED 1/20/12

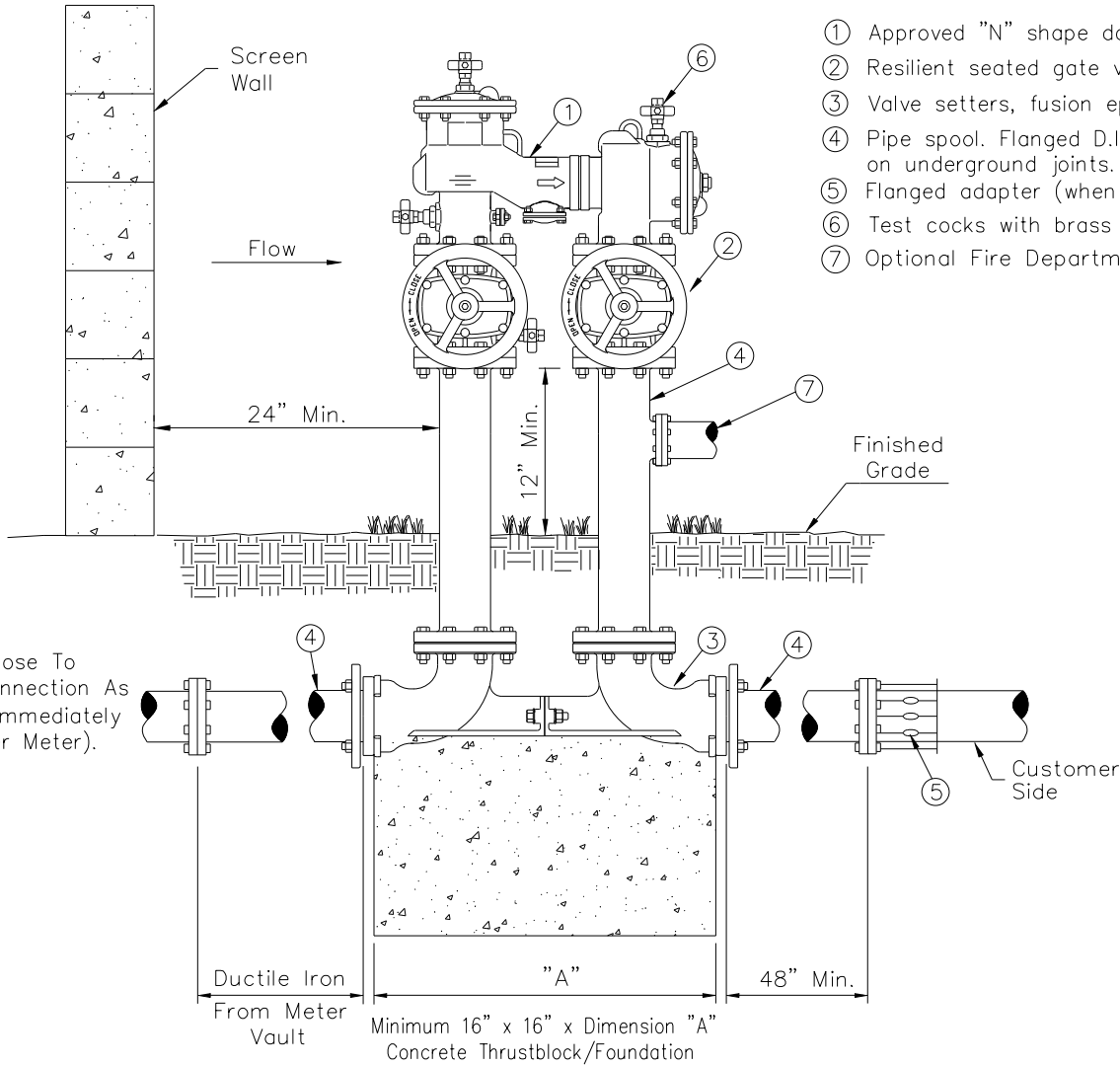

LIST OF MATERIALS

- ① Approved "N" shape double check valve backflow prevention assembly.
- ② Resilient seated gate valve. O.S. & Y. (fire line connection) N.R.S. (non fire line)
- ③ Valve setters, fusion epoxy coated ductile iron, plated nuts and bolts. (2 required)
- ④ Pipe spool. Flanged D.I.P. 3" thru 10", Mega Lug or approved equal may be used on underground joints.
- ⑤ Flanged adaptor (when required)
- ⑥ Test cocks with brass plugs or adaptors with caps installed. (4 required)
- ⑦ Optional Fire Department Connection (FDC) – see COS Std. Detail 2374.

GENERAL NOTES

- 1. Backflow backflow assemblies must be tested by a certified tester that is recognized by the City of Scottsdale.
- 2. Backflow preventers shall be painted light tan or a color to match the building. Do not paint the name plate or any brass parts on the assembly.
- 3. For backflow preventers requiring guard posts see Detail 2356. Backflow preventers enclosed by screening shall maintain a 24 inch clearance around the assembly.
- 4. Finished grade underneath the backflow preventer shall be at 95% compaction.
- 5. Backflow preventers on fire lines may require tamper switches on the shut off valves. Contact City Of Scottsdale Plan Review, Fire Dept.
- 6. Call for underground inspection before backfilling trench.
- 7. Seal Approval from the American Society of Sanitation Engineers. Backflow assemblies installed on fire suppression systems must also have approval from Underwriters Laboratories and/or Factory Mutual Research Corporation.

DETAIL NO.
2359

**City of Scottsdale
Standard Details**

APPROVED BY:
**Scottsdale Standards &
Specifications Committee**

**"N" SHAPED DOUBLE CHECK VALVE BACKFLOW PREVENTION
ASSEMBLY FOR ASSEMBLIES 3 INCHES THRU 10 INCHES**

DETAIL NO.
2359

REVISED 1/20/12

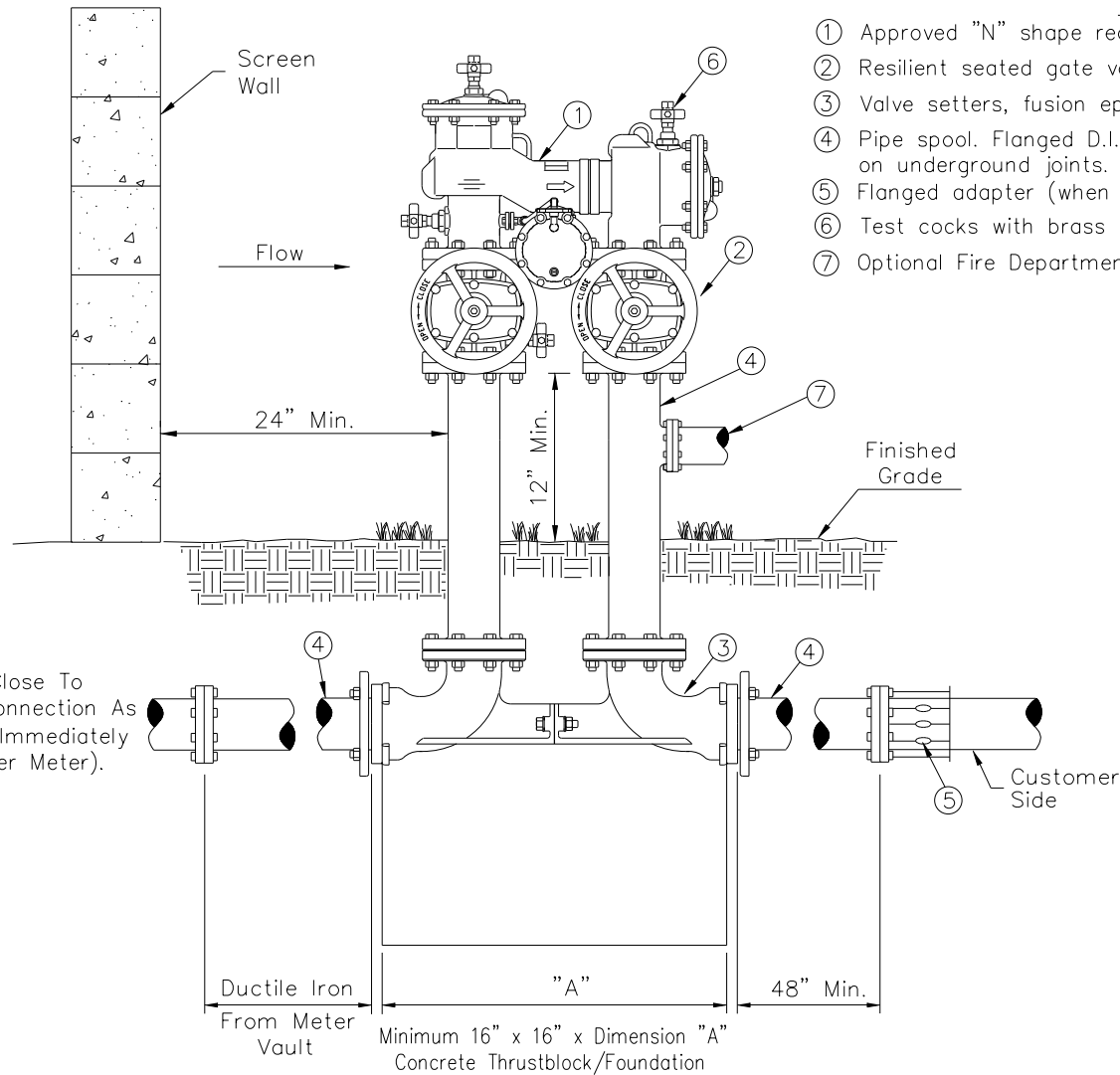

LIST OF MATERIALS

- ① Approved "N" shape reduced pressure principle backflow prevention assembly.
- ② Resilient seated gate valve. O.S. & Y. (fire line connection) N.R.S. (non fire line)
- ③ Valve setters, fusion epoxy coated ductile iron, plated nuts and bolts. (2 required)
- ④ Pipe spool. Flanged D.I.P. 3" thru 10", Mega Lug or approved equal may be used on underground joints.
- ⑤ Flanged adapter (when required)
- ⑥ Test cocks with brass plugs or adaptors with caps installed. (4 required)
- ⑦ Optional Fire Department Connection (FDC) – see COS Std. Detail 2374.

GENERAL NOTES

1. Backflow backflow assemblies must be tested by a certified tester that is recognized by the City of Scottsdale.
2. Backflow preventers shall be painted light tan or a color to match the building. Do not paint the name plate or any brass parts on the assembly.
3. For backflow preventers requiring guard posts see Detail 2356. Backflow preventers enclosed by screening shall maintain a 24 inch clearance around the assembly.
4. Finished grade underneath the backflow preventer shall be at 95% compaction.
5. Backflow preventers on fire lines may require tamper switches on the shut off valves. Contact City Of Scottsdale Plan Review, Fire Dept.
6. Call for underground inspection before backfilling trench.
7. Approvals for backflow assemblies must have Seal Approval from the American Society of Sanitation Engineers. Backflow assemblies installed on fire supression systems must also have approval from Underwriters Laboratories and/or Factory Mutual Research Corporation.

DETAIL NO.
2360

**City of Scottsdale
Standard Details**

APPROVED BY:
**Scottsdale Standards &
Specifications Committee**

**"N" SHAPED REDUCED PRESSURE PRINCIPLE BACKFLOW PREVENTION
ASSEMBLY FOR ASSEMBLIES 3 INCHES THRU 10 INCHES**

DETAIL NO.
2360

REVISED 6/15/06

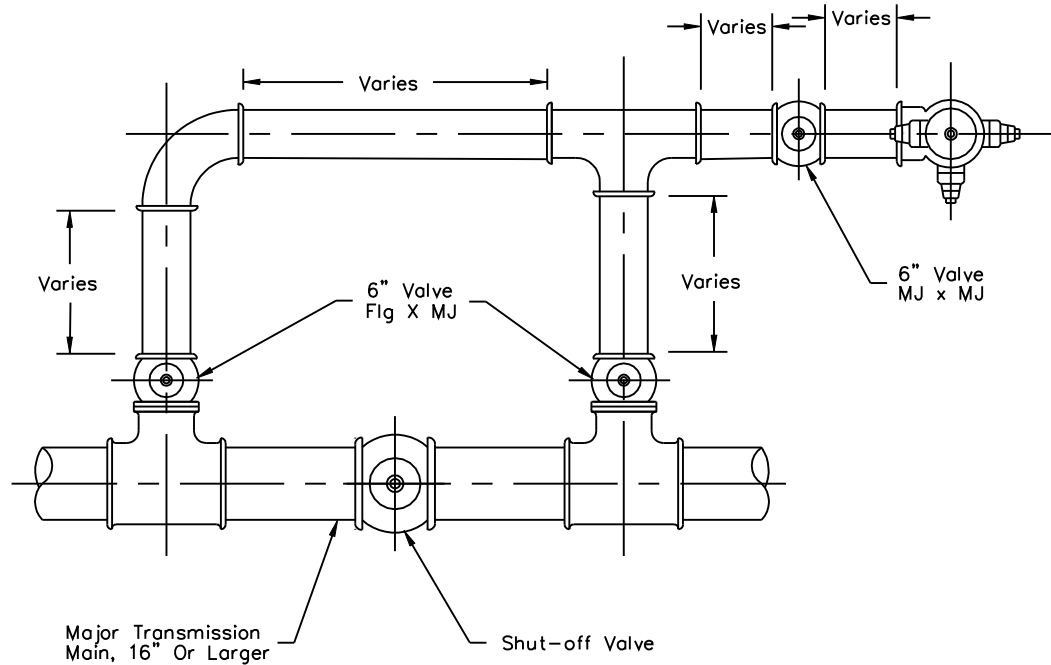
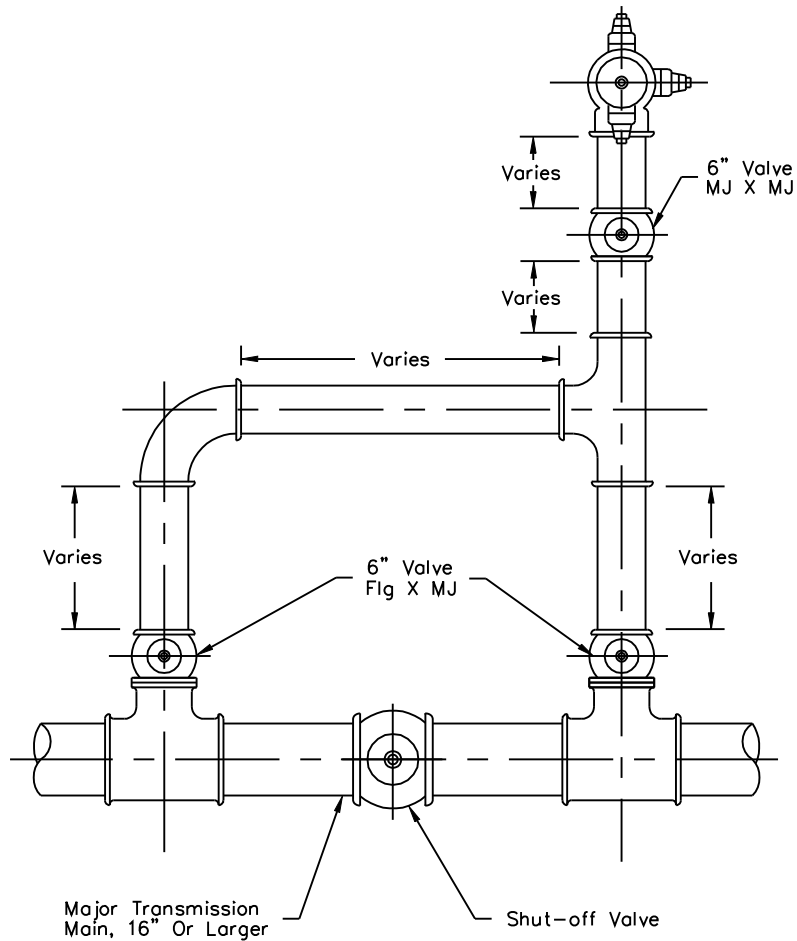

NOTES

1. All joints in hydrant run-out to be restrained joints.
2. See MAG Std. Detail 391-C for valve box installation.
3. For water valve blocking see MAG Std. Detail 301.
4. For additional information see MAG Std. Detail 360.

DETAIL NO. **2361**
City of Scottsdale
Standard Details

APPROVED BY:
Scottsdale Standards & Specifications Committee

FIRE HYDRANT BYPASS ASSEMBLY

DETAIL NO. **2361**

REVISED 5/22/07

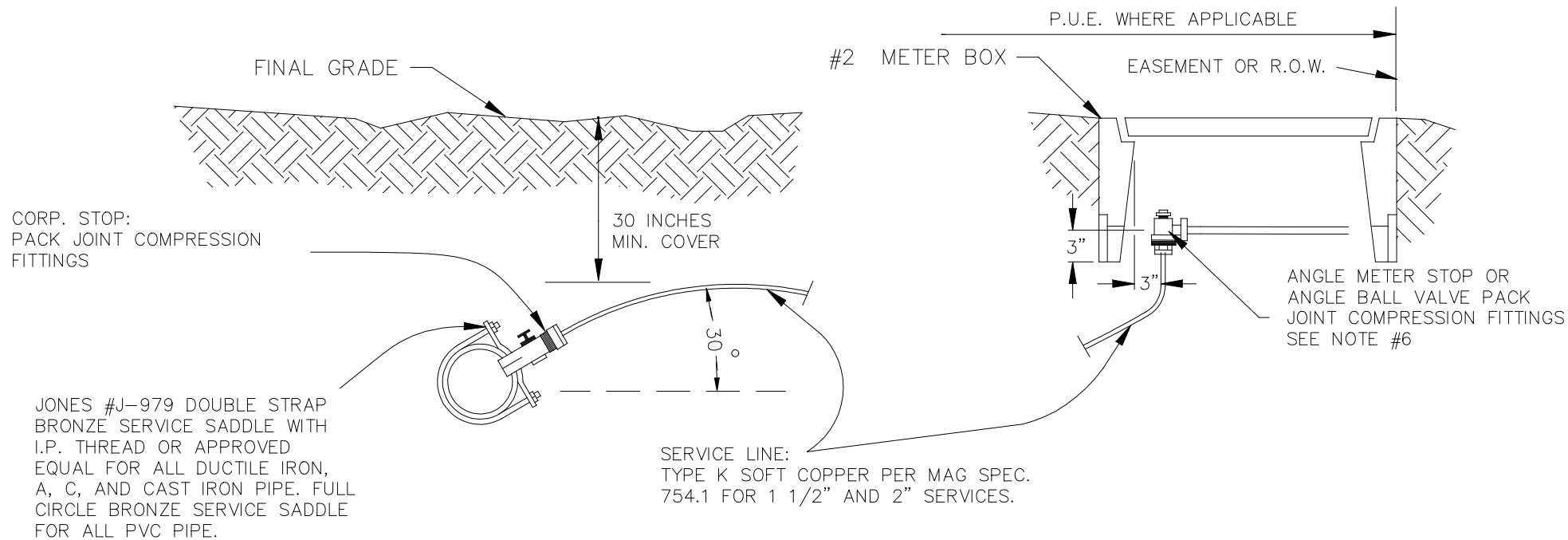

- NOTE:
1. All taps must be made using a service saddle.
 2. All service line sizes shall have the pack joint compression fittings for corp. stops and meter stops.
 3. Where a contractor is installing new water lines, all fire line connections shall also be installed. The contractor's installation shall include the service saddle, corp. stop, service pipe, appurtenant fittings, meter stop, concrete meter box and box cover, per M.A.G. Specifications.
 4. Copper service lines in the 1 1/2", and 2" sizes that cross streets will be one continuous piece. Only with the written consent of Water & Wastewater Operations will joints be permitted under a road. When this occurs, pack joint fittings will be required; no soldered joints will be permitted.
 5. Authorized City of Scottsdale Water and Wastewater Operations personnel or a City approved tapping contractor shall install the water service connections on existing mains.
 6. A fire Department Identification Tag is required. Water resistant tag shall be affixed to valve in meter box and shall state: "DO NOT CLOSE! Fire Sprinkler Supply Line".
 7. Rough grade shall be set to 1 1/2 inches below top of meter box. Final landscape grade shall be set flush to top of meter box

DETAIL NO. **2362-1**
City of Scottsdale
Standard Details

APPROVED BY:
Scottsdale Standards & Specifications Committee

1 1/2"-2" FIRE LINE CONNECTION

DETAIL NO. **2362-1**

REVISED 4/25/07

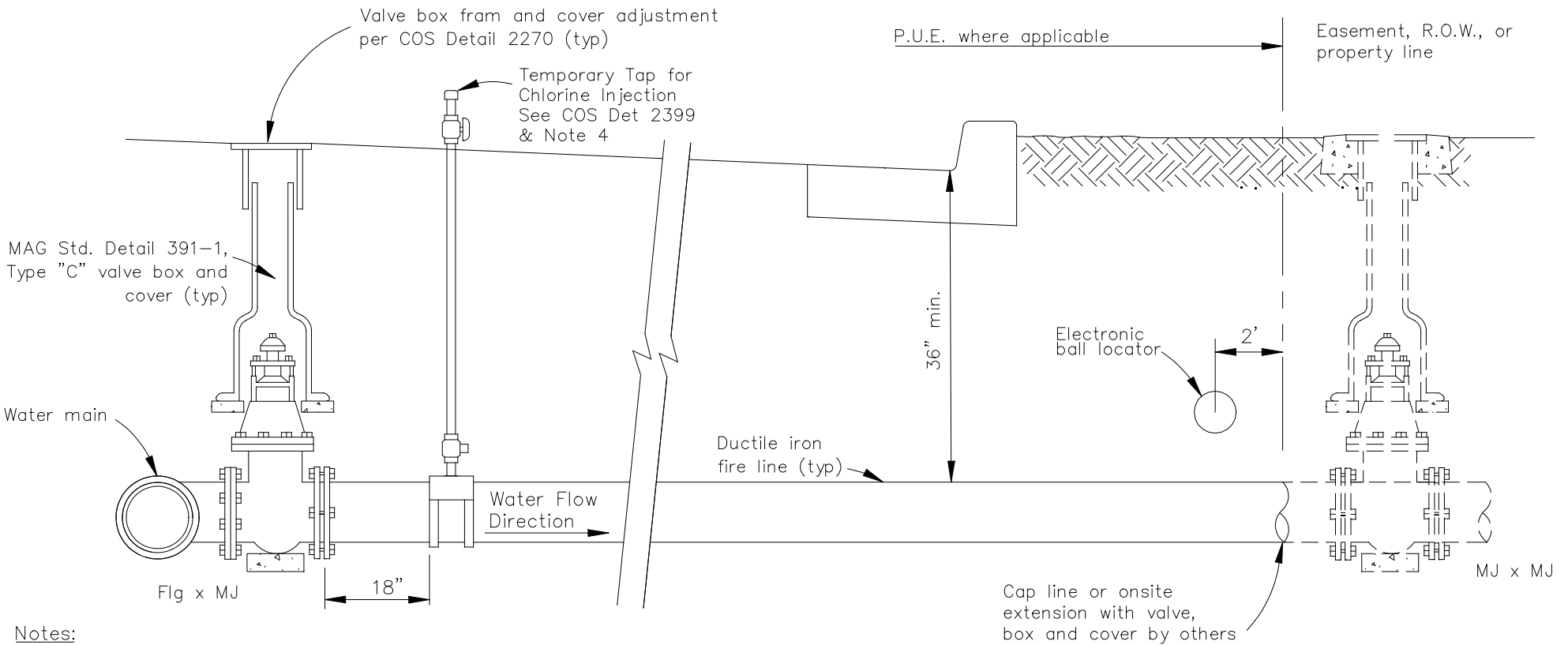

Notes:

1. All water lines within the right-of-way or public utility easement shall be polywrapped ductile iron pipe.
2. Joint restraint shall conform to the requirements of MAG Std. Detail 303.
3. When a water main is located behind the curb at the near side of the street, the gate valve by others is not required when the fire line is extended onto private property.
4. All 3" and larger fire lines are required to be disinfected and tested in accordance with MAG Section 611. A corporation stop shall be inserted in the top of the pipe 18" downstream from the tapping valve and will be used as the chlorine injection point.

DETAIL NO. 2362-2	City of Scottsdale Standard Details	APPROVED BY: Scottsdale Standards & Specifications Committee	3" AND LARGER FIRE LINE CONNECTION	DETAIL NO. 2362-2
-----------------------------	--	--	---	-----------------------------

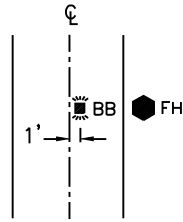

Midblock Local

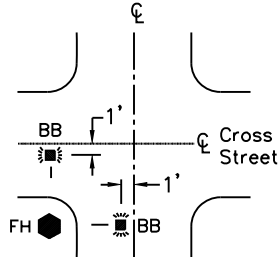

Local Cross Intersection

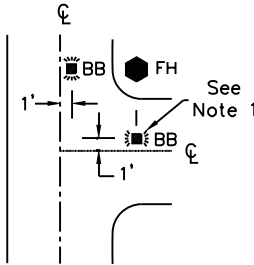

Local T Intersection

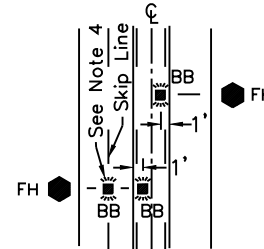

Midblock WITH CENTER LANE OR SKIP LINES

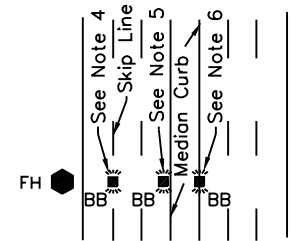

Midblock WITH RAISED MEDIAN

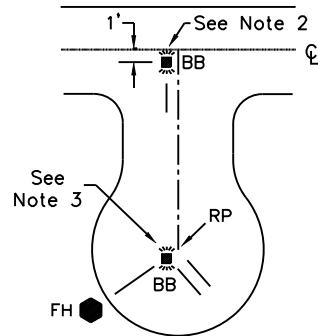

Cul-De-Sac Street

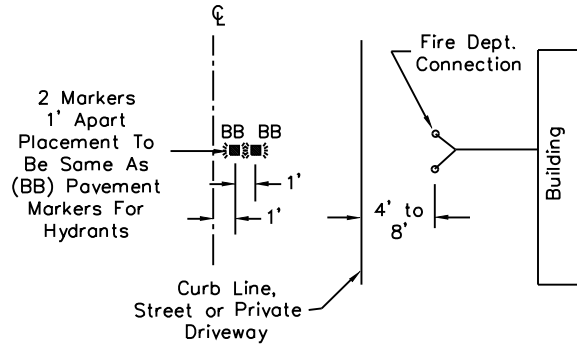

Fire Dept. Connection

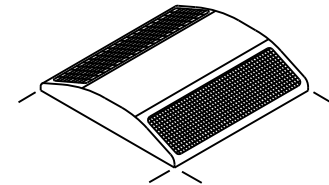

Pavement Marker
(2-WAY REFLECTIVE BLUE)
(ADOT TYPE BB)

NOTES:

1. Not Required on Dead End Streets Without Hydrants
2. Place on Hydrant Side of Centerline.
3. Not Required When Cul-De-Sac is Less Than 250'.
4. To Be Placed in Line With Skip Line.
5. Place on Gutter or Adjacent To Curb.
6. Place on Top of Curb. (This Location Optional)
7. Pavement Markers Shall Not Be Placed Within One Foot of A Paint Line (Center to Center).

DETAIL NO.
2363

City of Scottsdale
Standard Details

APPROVED BY:
Scottsdale Standards & Specifications Committee

PAVEMENT MARKERS FOR FIRE HYDRANTS

DETAIL NO.
2363

REVISED 4/22/09

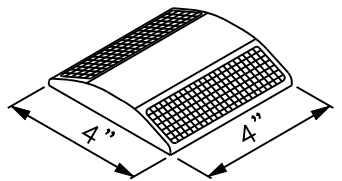

Pavement Marker
(2-WAY REFLECTIVE BLUE)
(ADOT TYPE BB)
DETAIL "A"

* NOTE:
Sidewalk And/Or 2"
Max. Ground Cover
Over Min. 6" ABC

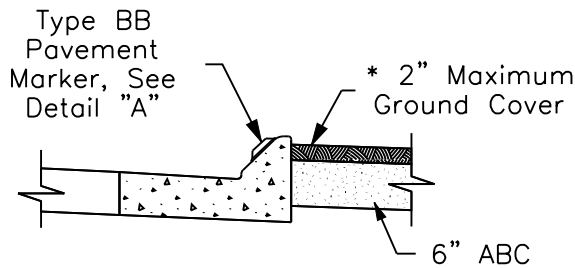

**TYPE "M" MOUNTABLE
CURB AND GUTTER**

DETAIL "B"

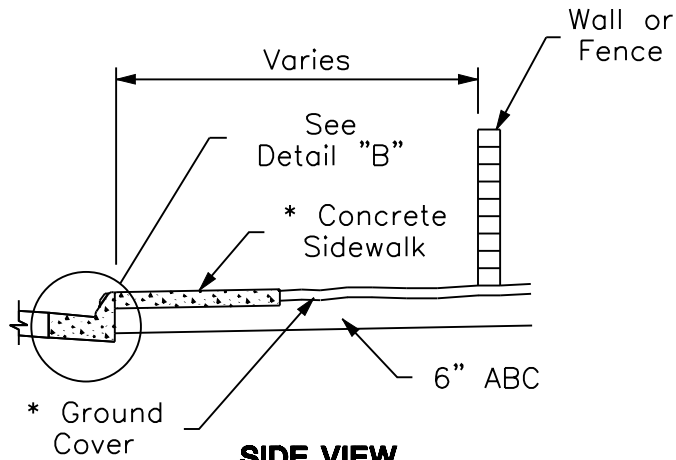

SIDE VIEW

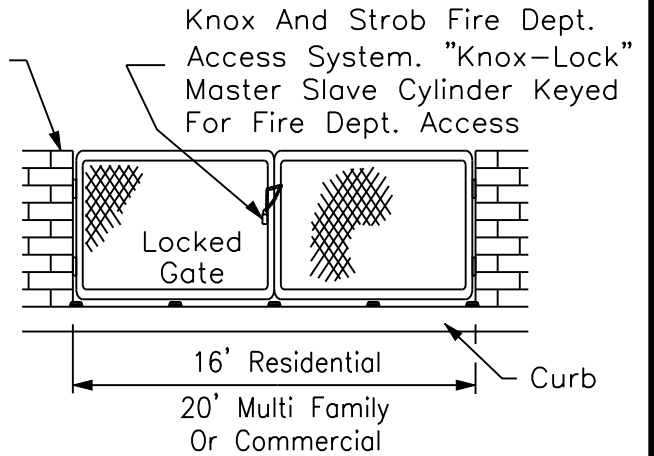

FRONT VIEW

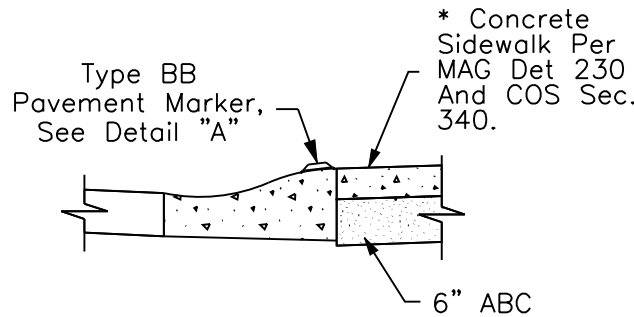

ROLL CURB

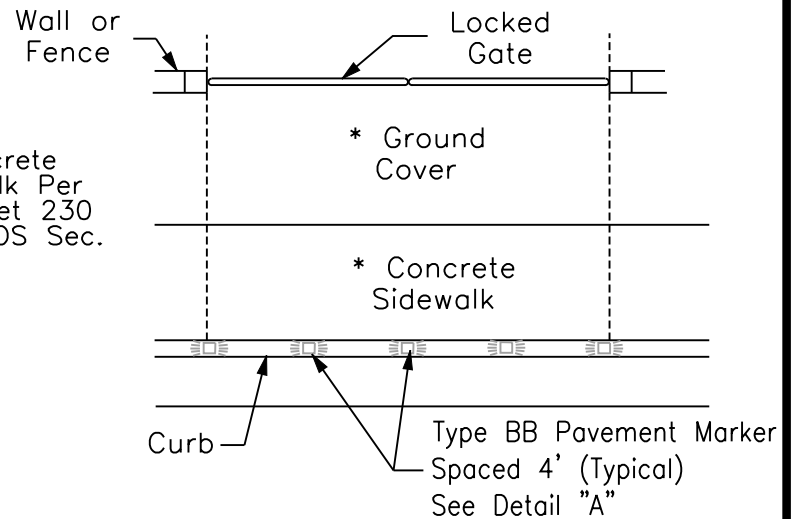

TOP VIEW

DETAIL NO.
2364

**City of Scottsdale
Standard Details**

APPROVED BY:
**Scottsdale Standards &
Specifications Committee**

**FIRE AND EMERGENCY ACCESS
AND DELINEATION**

DETAIL NO.
2364

REVISED 4/15/09



NOTES:

1. At the beginning and end of the fire lane, the sign shall have a single headed arrow pointing in the direction the regulation is in effect. The intermediate signs shall have double headed arrows pointing in both directions.
2. The maximum spacing of the signs shall be 100', contingent upon Traffic Engineering's review and approval.
3. The signs shall be set at an angle of not less than 30° nor more than 45° with the curb or line of traffic flow
4. The clearance to the bottom of the sign shall be 7 feet. There shall be no other signs attached to the sign or the sign pole.
5. The sign substrate shall be a minimum of 12" x 18" treated aluminum with a thickness of 0.080".
6. The sign face shall have a white, ASTM Type IV reflective background with a red screen printed or translucent acrylic EC overlay film reflective legend. Use the standard sign face number R7-32 or equivalent incorporating additional information to complete the sign as shown.

DETAIL NO.
2365

City of Scottsdale
Standard Details

APPROVED BY:
Scottsdale Standards & Specifications Committee

FIRE LANE SIGN

DETAIL NO.
2365

REVISED: 4/30/04

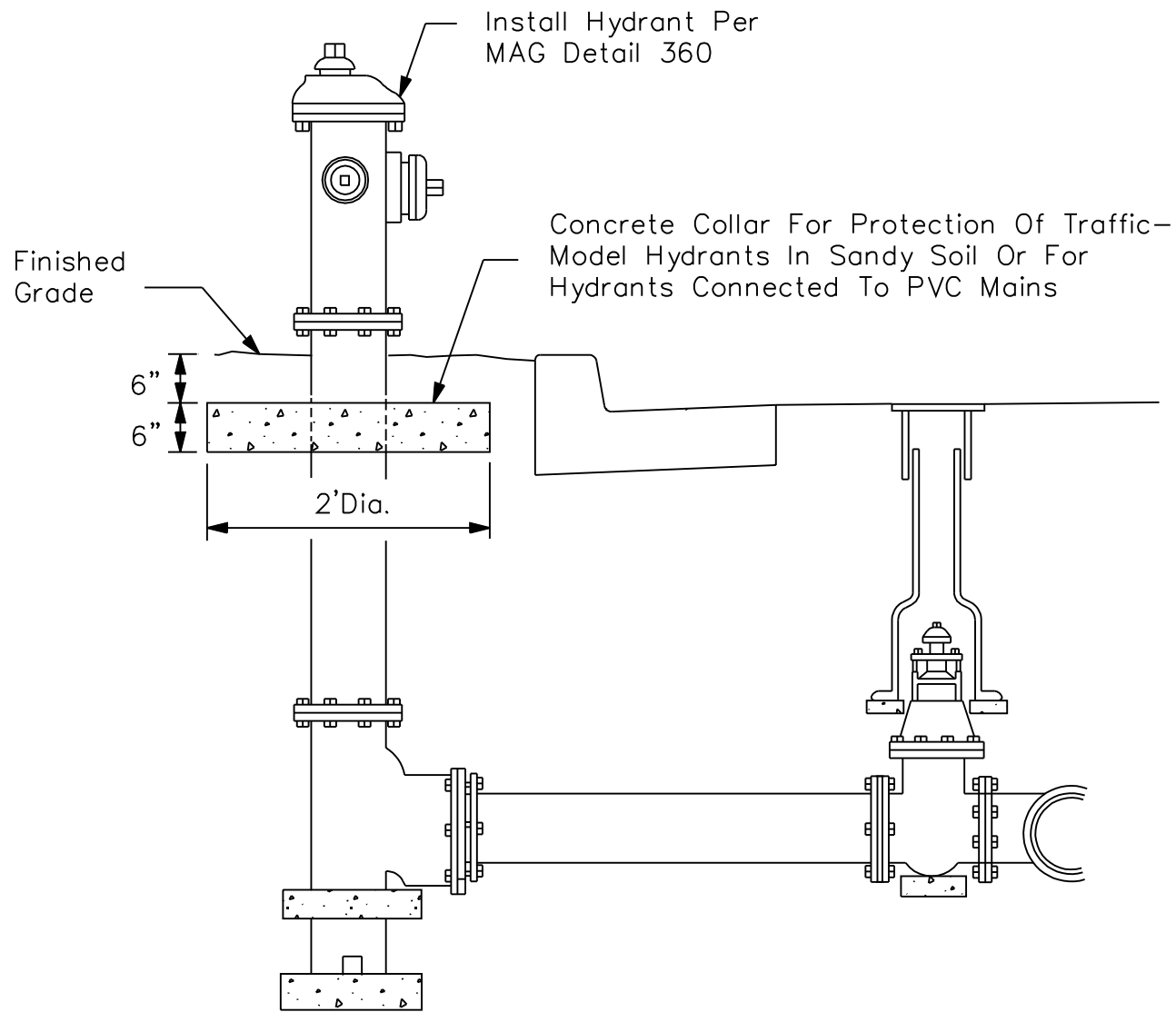

DETAIL NO.
2366

**City of Scottsdale
Standard Details**

APPROVED BY:
**Scottsdale Standards &
Specifications Committee**

CONCRETE COLLAR FOR FIRE HYDRANTS

DETAIL NO.
2366

GENERAL NOTES

1. Provide Building I.D. On Remote Fire Dept. Connection.
2. No Trees, Bushes Or Walls Within 5' Radius Of Fire Dept. Connection
3. If Fire Sprinkler Design Indicates Demand Of 1000 GPM Or Greater, The Underground Fire Dept. Connection Line Shall Be Increased To 6" Diameter With A Three Way 2 1/2" Fire Dept. Hose Connection
4. 4' Min. To Back Of Curb, or 2' Min To Back Of Sidewalk, or When No Curb, 4' Max. Outside The Clear Zone.

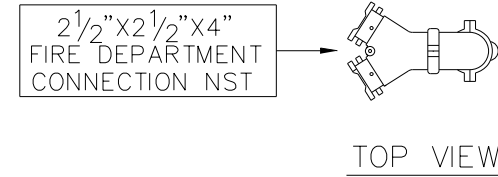

TOP VIEW

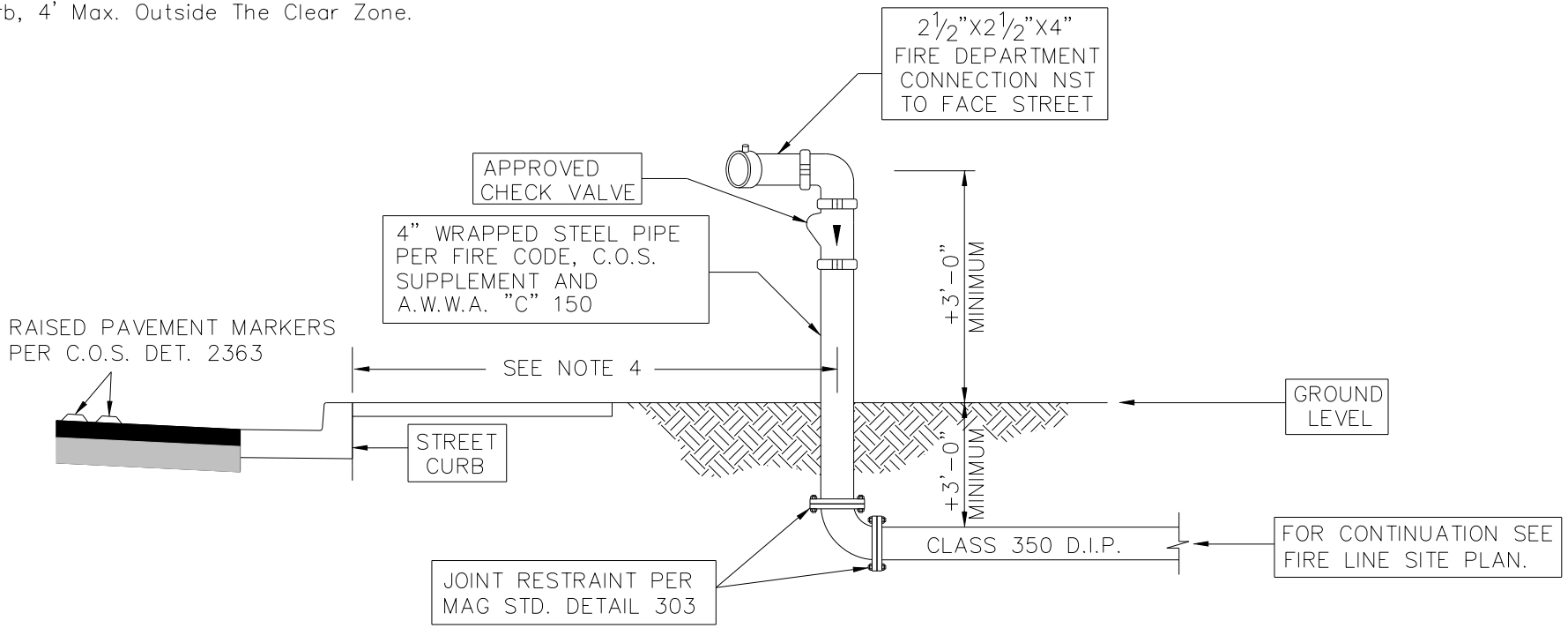

SIDE VIEW

REVISED 12/21/11

DETAIL NO.
2367

**City of Scottsdale
Standard Details**

APPROVED BY:
**Scottsdale Standards &
Specifications Committee**

**FIRE DEPARTMENT
REMOTE SIAMESE CONNECTION**

DETAIL NO.
2367

REVISED 3/1/12

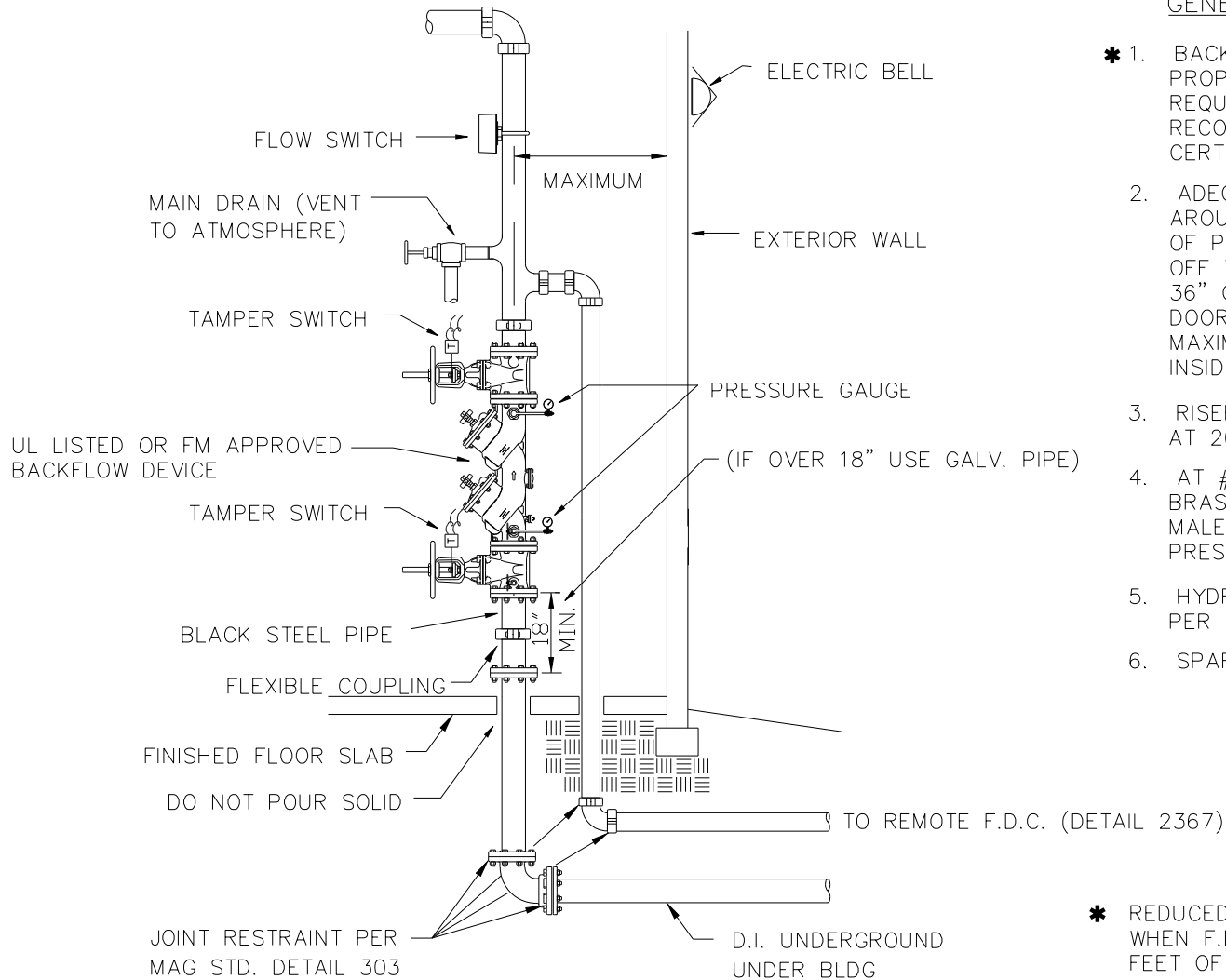

GENERAL NOTES

- * 1. BACKFLOW PREVENTER SHALL BE TESTED FOR PROPER OPERATION PER CITY OF SCOTTSDALE REQUIREMENTS BY A CERTIFIED TESTER RECOGNIZED BY THE CITY, BEFORE A TEMPORARY CERTIFICATE OF OCCUPANCY IS ISSUED.
- 2. ADEQUATE CLEARANCE SHALL BE PROVIDED AROUND FIRE RISER. DIMENSIONS FROM FACE OF PIPE SHALL MEASURE A MINIMUM OF 12" OFF THE BACK WALL, 18" ON EACH SIDE AND 36" CLEAR IN FRONT WITH A FULL HEIGHT DOOR. THE FIRE LINE SHALL EXTEND A MAXIMUM OF 3' INTO THE BUILDING FROM INSIDE FACE OF WALL TO CENTER OF PIPE.
- 3. RISER SHALL BE HYDROSTATICALLY TESTED AT 200 PSI FOR TWO HOURS.
- 4. AT #1 & #4 TEST PORTS INSTALL A 1/2" BRASS NIPPLE, TEE & PLUGS W/1/2" x 1/4" MALE FLARED CONNECTION W/ CAP (INSTALL PRESSURE GAUGE ON TEE OUTLET)
- 5. HYDRAULIC DESIGN AND SUMMARY INFORMATION PER NFPA SHALL BE ATTACHED TO RISER.
- 6. SPARE HEAD BOX SHALL BE MOUNTED IN AREA.

* REDUCED-PRESSURE BACKFLOW REQUIRED WHEN F.D. CONNECTION IS WITHIN 1700 FEET OF AN AUXILIARY SUPPLY.

DETAIL NO.
2368

**City of Scottsdale
Standard Details**

APPROVED BY:
**Scottsdale Standards &
Specifications Committee**

**FIRE SPRINKLER RISER DETAIL WITH
REMOTE FD CONNECTION**

DETAIL NO.
2368

REVISED 3/1/12

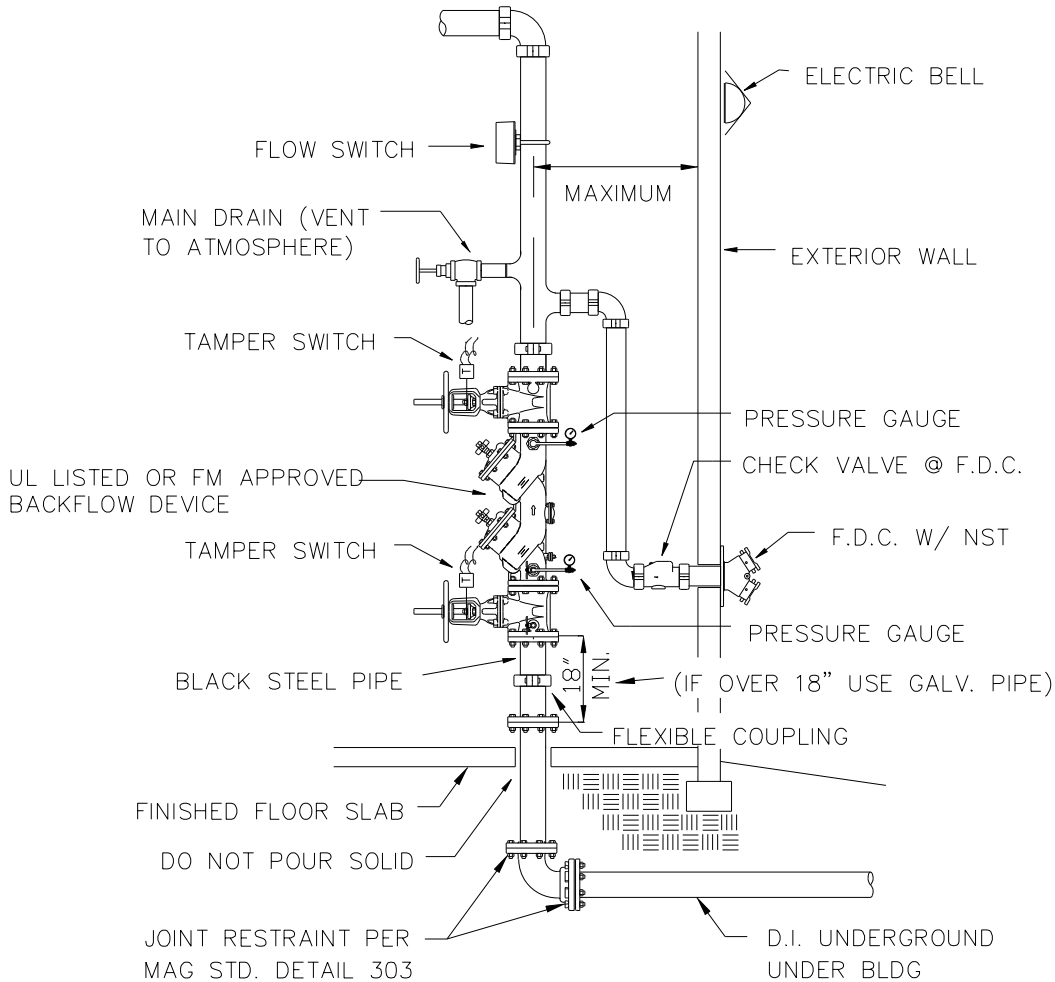

GENERAL NOTES

- * 1. BACKFLOW PREVENTER SHALL BE TESTED FOR PROPER OPERATION PER CITY OF SCOTTSDALE REQUIREMENTS BY A CERTIFIED TESTER RECOGNIZED BY THE CITY, BEFORE A TEMPORARY CERTIFICATE OF OCCUPANCY IS ISSUED.
- 2. ADEQUATE CLEARANCE SHALL BE PROVIDED AROUND FIRE RISER. DIMENSIONS FROM FACE OF PIPE SHALL MEASURE A MINIMUM OF 12" OFF THE BACK WALL, 18" ON EACH SIDE AND 36" CLEAR IN FRONT WITH A FULL HEIGHT DOOR. THE FIRE LINE SHALL EXTEND A MAXIMUM OF 3' INTO THE BUILDING FROM INSIDE FACE OF WALL TO CENTER OF PIPE.
- 3. RISER SHALL BE HYDROSTATICALLY TESTED AT 200 PSI FOR TWO HOURS.
- 4. AT #1 & #4 TEST PORTS INSTALL A 1/2" BRASS NIPPLE, TEE & PLUGS W/1/2" x 1/4" MALE FLARED CONNECTION W/ CAP (INSTALL PRESSURE GAUGE ON TEE OUTLET)
- 5. HYDRAULIC DESIGN AND SUMMARY INFORMATION PER NFPA SHALL BE ATTACHED TO RISER.
- 6. SPARE HEAD BOX SHALL BE MOUNTED IN AREA.

* REDUCED-PRESSURE BACKFLOW REQUIRED WHEN F.D. CONNECTION IS WITHIN 1700 FEET OF AN AUXILIARY SUPPLY.

DETAIL NO.
2369

**City of Scottsdale
Standard Details**

APPROVED BY:
**Scottsdale Standards &
Specifications Committee**

**FIRE SPRINKLER RISER DETAIL WITH
WALLMOUNT FD CONNECTION**

DETAIL NO.
2369

REVISED 1/18/12

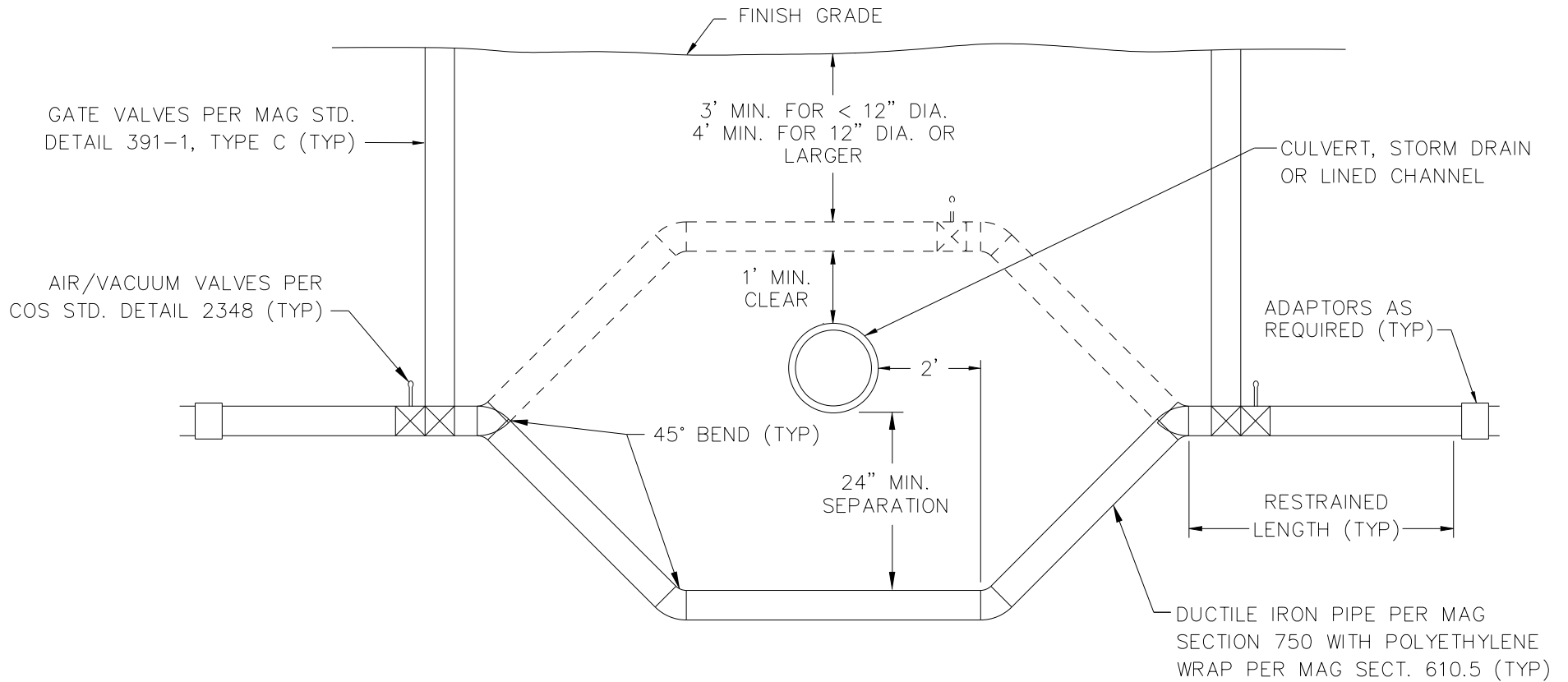

NOTES:

1. DETAIL ONLY ILLUSTRATES MINIMUM SEPARATION AND COVER REQUIREMENTS.
2. QUANTITIES FOR PIPE, FITTINGS, VALVES AND RESTRAINT PER PLANS, INCLUDING ANY REMOVALS, TEMPORARY SUPPORT, SURFACE RESTORATION, ETC.
3. ALL JOINTS TO BE RESTRAINED PER MAG STD. DETAIL 303-1 AND 303-2 UNLESS OTHERWISE NOTED ON THE PLANS.
4. GATE VALVES AND AIR/VACUUM VALVES INSTALLED AS SHOWN UNLESS NOTED OTHERWISE ON THE PLANS.
5. BENDS NOT ADJACENT TO A GATE VALVE SHALL BE INSTALLED WITH BALL MARKERS PER COS STD. DETAIL 2397.

DETAIL NO.
2370

**City of Scottsdale
Standard Details**

APPROVED BY:
**Scottsdale Standards &
Specifications Committee**

VERTICAL REALIGNMENT OF WATER MAINS

DETAIL NO.
2370

REVISED 3/25/09

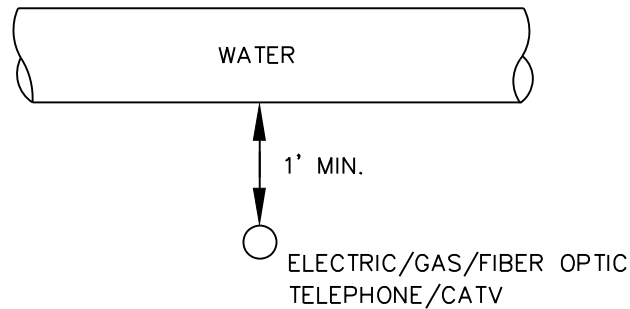
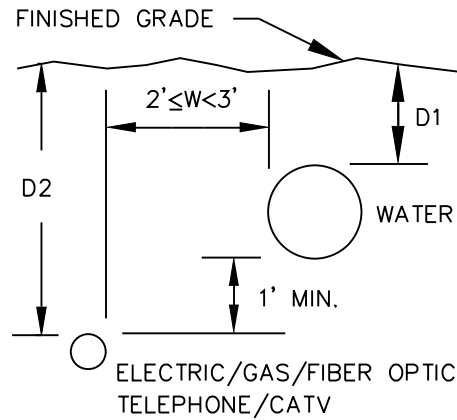

CROSSING

LEGEND:

- D1 = { 3' Min. for pipe < 12" dia.
4' Min. for pipe = 12" dia.
5' Min. for pipe > 12" dia.
- D2 = Minimum Cover
- W = Horizontal Separation

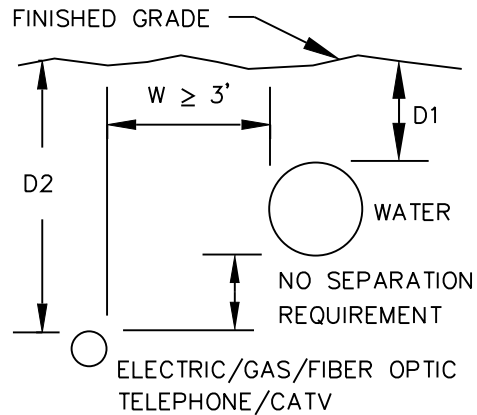

NOTES:

1. Electric separation requirements are for primary electric conductors only. For service conductors see plans.
2. Primary electric, gas, telephone, cable TV or fiber optic lines shall not cross above a water line without written approval from the City's Water Resources Department. If this approval is obtained, a utility locator strip and ABC slurry conforming to COS Specifications Sec. 601.3.6 are required.

DETAIL NO.
2372

City of Scottsdale
Standard Details

APPROVED BY:
Scottsdale Standards & Specifications Committee

MINIMUM UTILITY
SEPARATION REQUIREMENTS

DETAIL NO.
2372

NEW 1/19/12

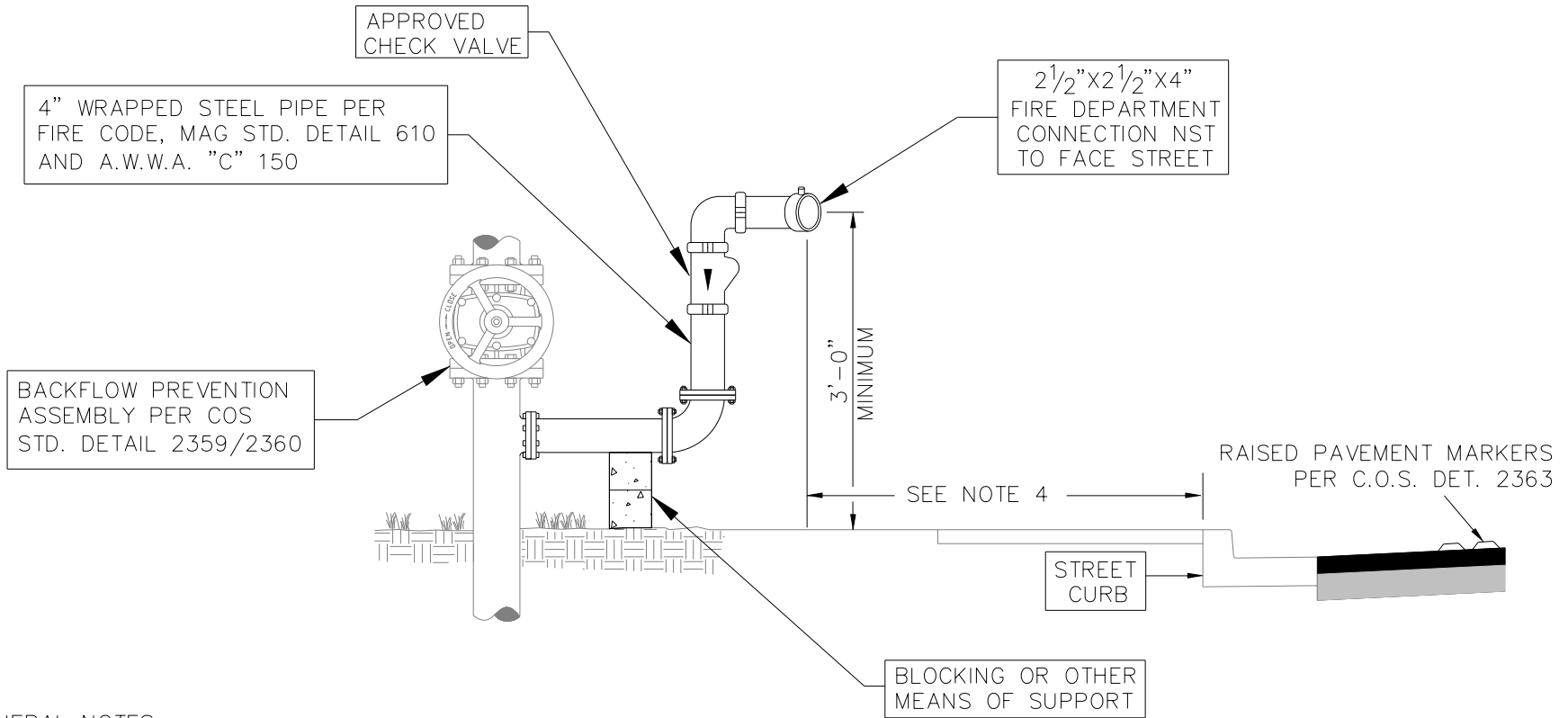

GENERAL NOTES

1. Provide Building I.D. On Remote Fire Dept. Connection.
2. No Trees, Bushes Or Walls Allowed Within 5' Radius Of Fire Dept. Connection
3. If Fire Sprinkler Design Indicates Demand Of 1000 GPM Or Greater, The Underground Fire Dept. Connection Line Shall Be Increased To 6" Diameter With A Three Way 2-1/2" Fire Dept. Hose Connection
4. 4' Min. To Back Of Curb, or 2' Min To Back Of Sidewalk, or When No Curb, 4' Max. Outside The Clear Zone.

DETAIL NO.
2374

**City of Scottsdale
Standard Details**

APPROVED BY:
**Scottsdale Standards &
Specifications Committee**

**REMOTE FIRE DEPARTMENT CONNECTION
TO BACKFLOW PREVENTION ASSEMBLY**

DETAIL NO.
2374

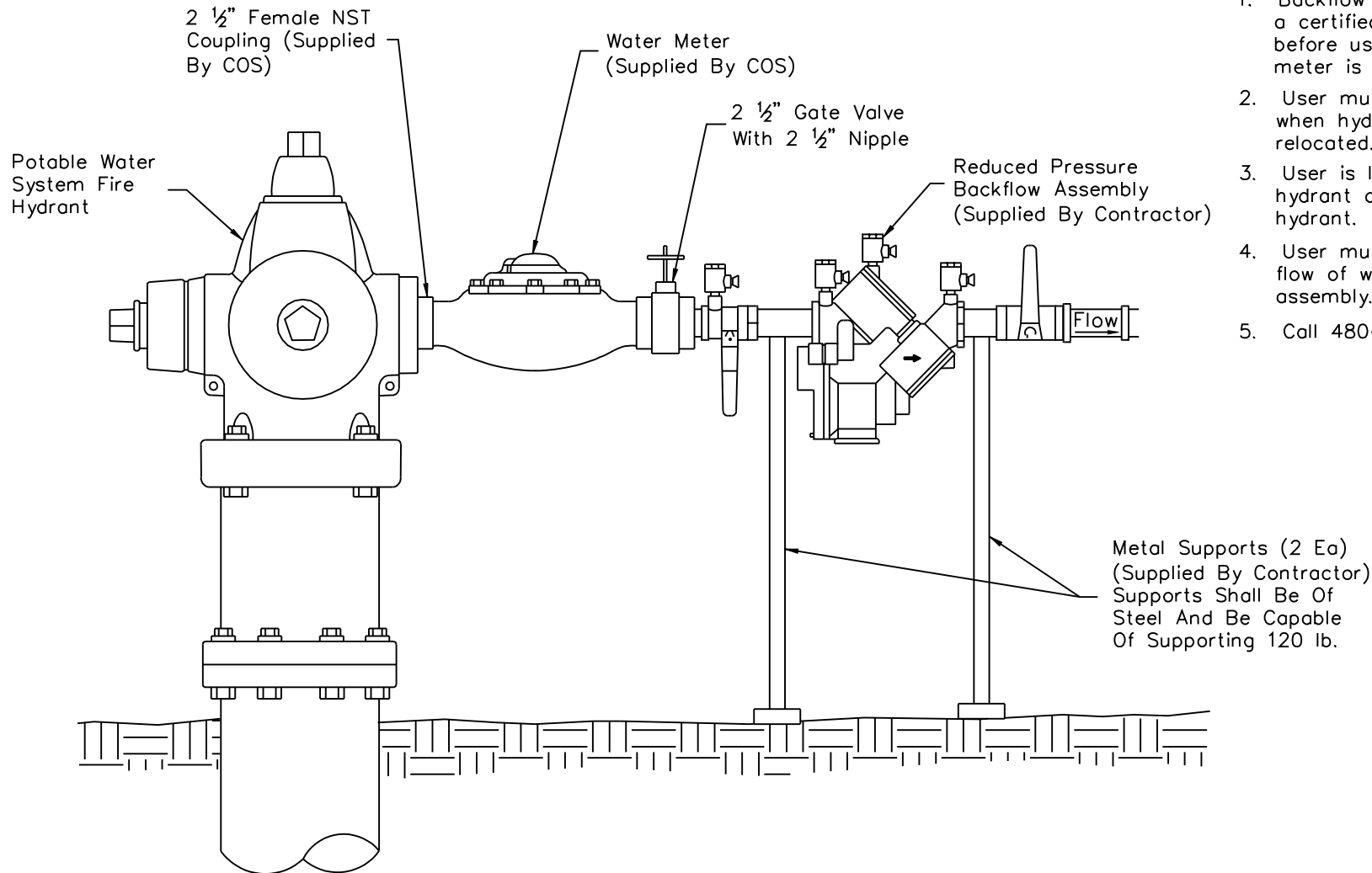

GENERAL NOTES

1. Backflow assembly shall be tested by a certified backflow assembly tester before using and also each time the meter is moved.
2. User must remove backflow assembly when hydrant meter is removed or relocated.
3. User is liable for any damage to the hydrant and all attachments to the hydrant.
4. User must use gate valve to control flow of water, not the hydrant valve assembly.
5. Call 480-312-5650 for questions.

DETAIL NO.
2380

**City of Scottsdale
Standard Details**

APPROVED BY:
**Scottsdale Standards &
Specifications Committee**

TEMPORARY WATER SUPPLY HYDRANT METER ASSEMBLY

DETAIL NO.
2380

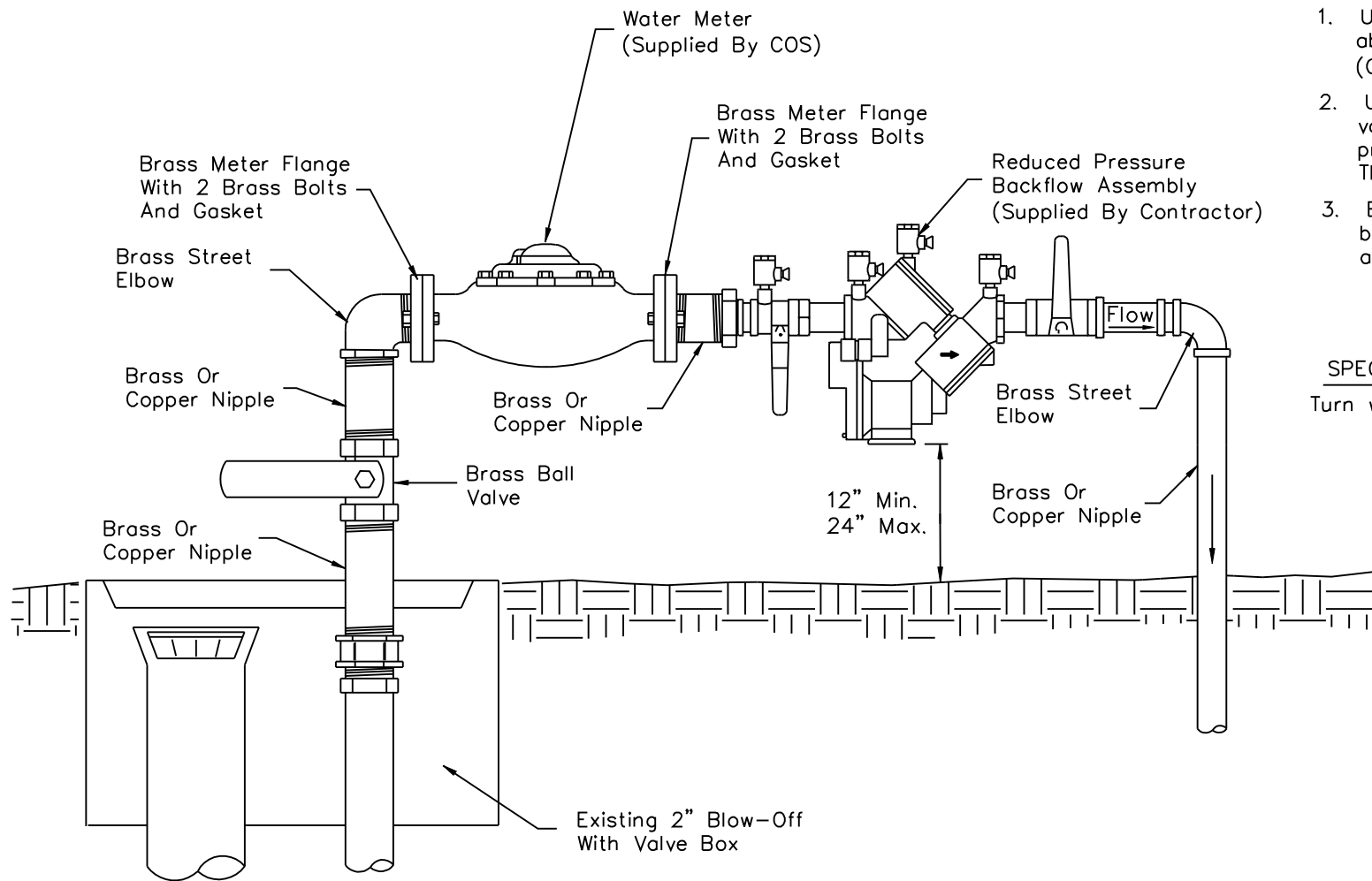

GENERAL NOTES

1. User must install City water meter above grade for temporary use. (One year maximum)
2. User must supply all fittings, piping, valves and approved reduced pressure principle backflow prevention assembly. The City shall supply the water meter.
3. Backflow assembly must be tested before use by a certified backflow assembly tester.

SPECIAL NOTE

Turn water on and off slowly.

DETAIL NO.
2381

City of Scottsdale
Standard Details

APPROVED BY:
Scottsdale Standards & Specifications Committee

TEMPORARY BLOW-OFF FOR WATER SUPPLY

DETAIL NO.
2381

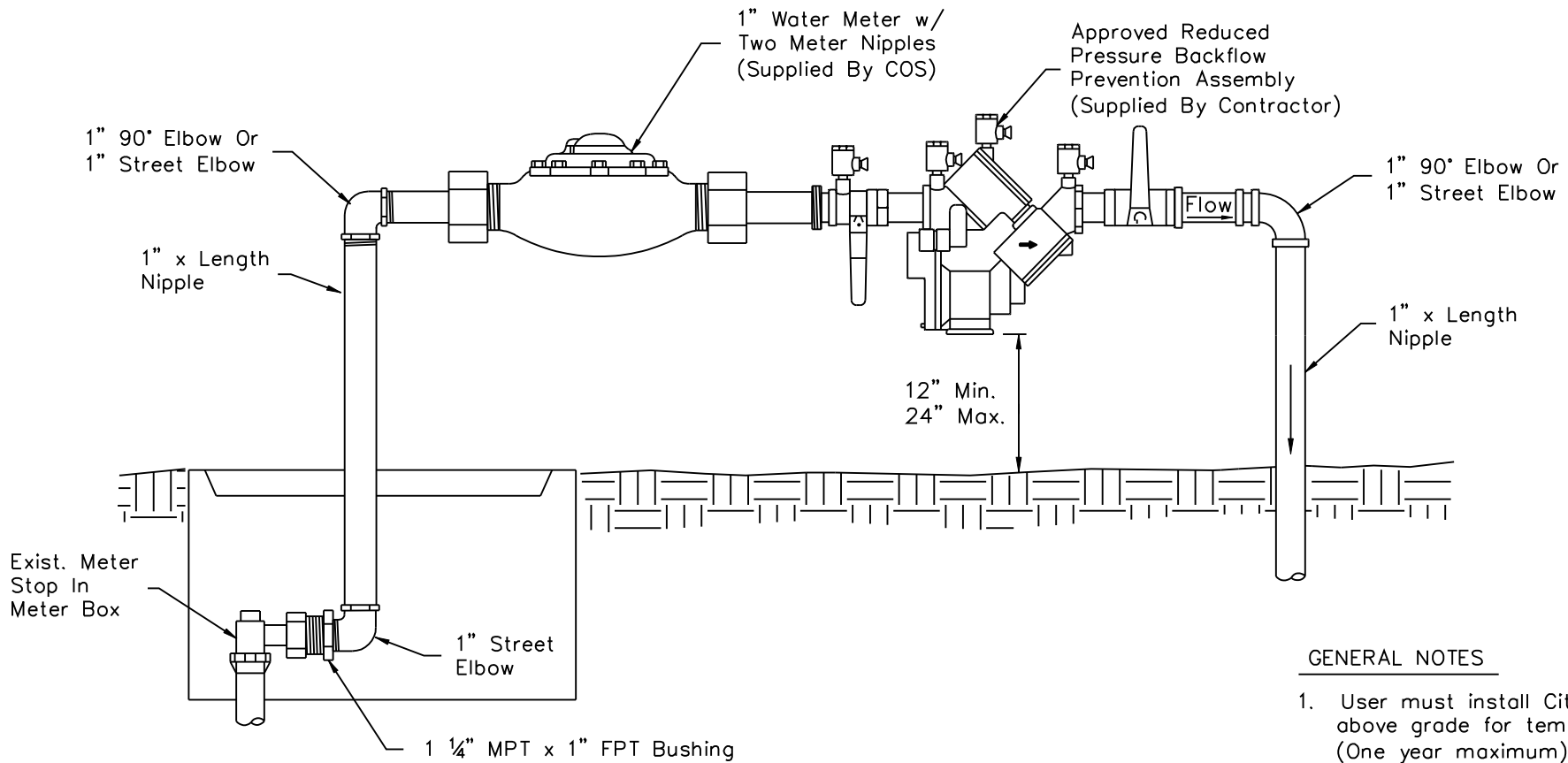

GENERAL NOTES

1. User must install City water meter above grade for temporary use. (One year maximum)
2. User must supply all fittings, nipples, valves and approved reduced pressure principle backflow prevention assembly. All fittings and nipples must be brass. The City shall supply the water meter.
3. Backflow assembly must be tested before use by a certified backflow assembly tester.

DETAIL NO.
2382

**City of Scottsdale
Standard Details**

APPROVED BY:
**Scottsdale Standards &
Specifications Committee**

TEMPORARY WATER SERVICE

DETAIL NO.
2382

REVISED 4/04/08

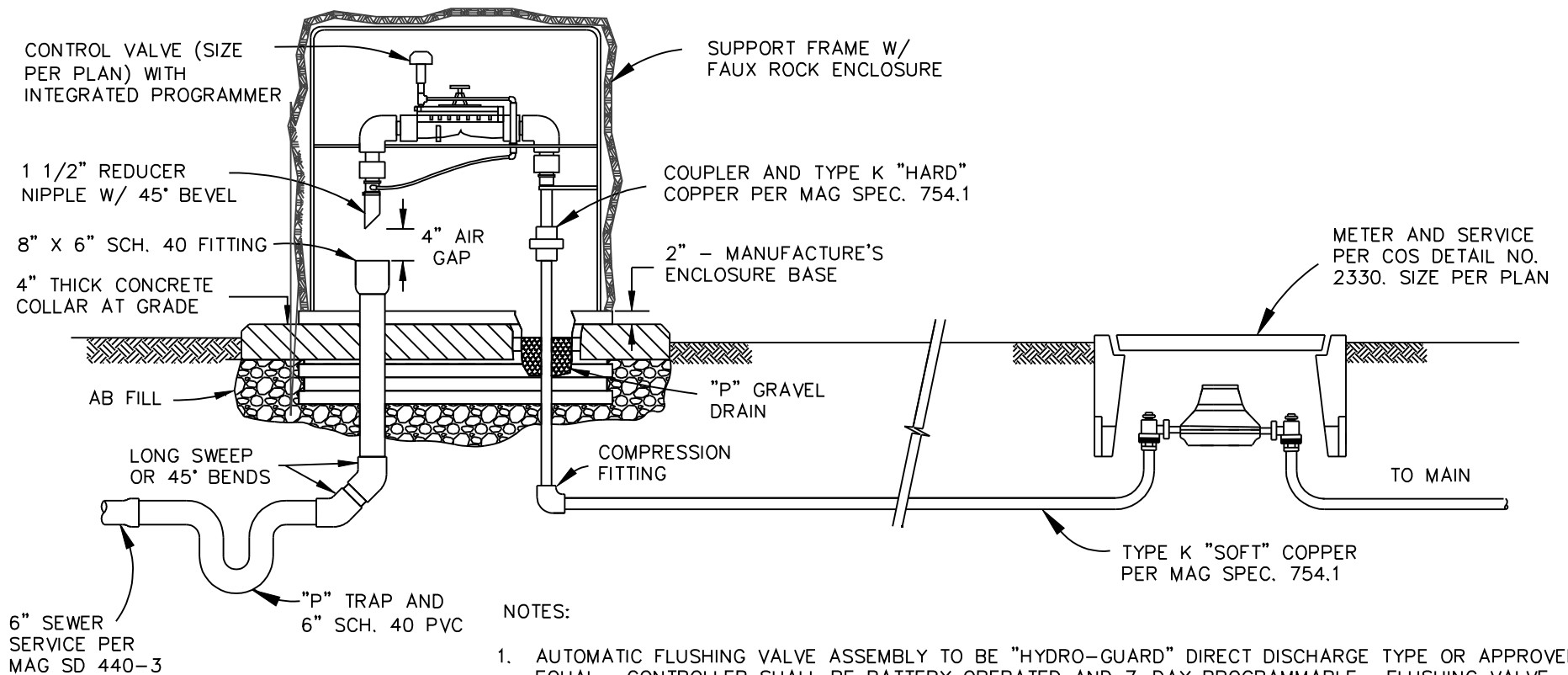

NOTES:

1. AUTOMATIC FLUSHING VALVE ASSEMBLY TO BE "HYDRO-GUARD" DIRECT DISCHARGE TYPE OR APPROVED EQUAL. CONTROLLER SHALL BE BATTERY OPERATED AND 7-DAY PROGRAMMABLE. FLUSHING VALVE SHALL BE CORROSION RESISTANT AND RATED BETWEEN 20 AND 150-PSI OPERATING PRESSURE. VALVE, CONTROLLER, AND BATTERY PACK SHALL REMAIN DRY AT ALL TIMES.
2. ALL MOUNTING BRACKETS AND HARDWARE SHALL BE STAINLESS STEEL.
3. FAUX ROCK ENCLOSURE SHALL BE MANUFACTURED BY CHANNEL, OR AN APPROVED EQUAL, COLORED TO BE CONSISTENT WITH ONSITE NATIVE MATERIAL, AND SECURED BY AN INTEGRATED LOCKING DEVICE.
4. DRAINAGE SHALL BE DIRECTED AWAY FROM THE ASSEMBLY.

DETAIL NO.
2383

**City of Scottsdale
Standard Details**

APPROVED BY:
**Scottsdale Standards &
Specifications Committee**

WATER LINE FLUSHING ASSEMBLY

DETAIL NO.
2383

REVISED 5/07/07

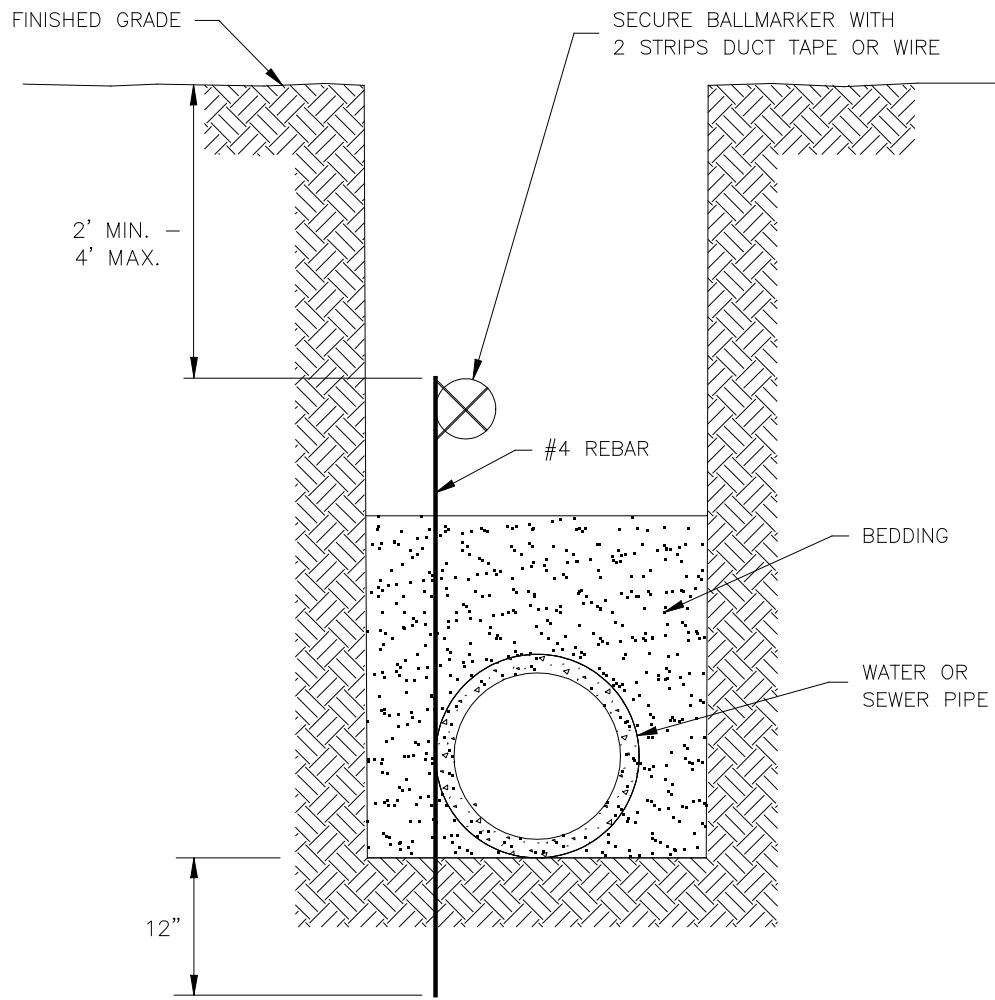

DETAIL NO.
2397

**City of Scottsdale
Standard Details**

APPROVED BY:
**Scottsdale Standards &
Specifications Committee**

ELECTRONIC BALLMARKER PLACEMENT

DETAIL NO.
2397

REVISED 4/30/04

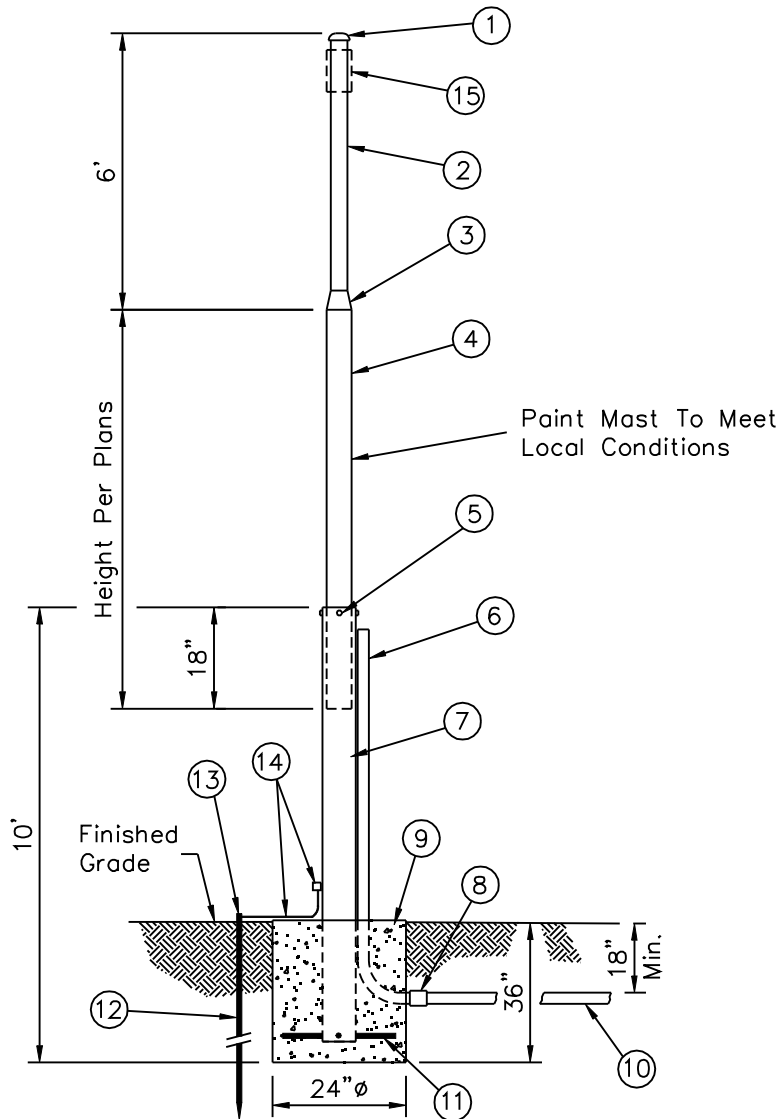

LIST OF MATERIALS

- ① Raintight Cap
- ② 2" Galvanized Rigid Steel Conduit
- ③ 2 1/2" To 2" Galvanized Steel Reducer
- ④ 2 1/2" Galvanized Rigid Steel Conduit
- ⑤ 1/2" Set Screw (Typ. - 4 Each)
- ⑥ 1" Rigid Steel Conduit, Strap To Mast
Install Bushing On Top Of Conduit
- ⑦ 3" Galvanized Rigid Steel Conduit
- ⑧ PVC To Rigid Steel Conduit Fitting
- ⑨ Concrete Foundation, Class "B"
- ⑩ 1" PVC Conduit To Radio Transceiving Unit
- ⑪ #5 Rebar (8" Length) Welded To
3" Conduit (Typ. - 4 Each)
- ⑫ 5/8" ϕ x 8' Long Grounding Rod
- ⑬ Acorn Nut Connection
- ⑭ Ground Attached To 3" Conduit
Using Lug And Self Tapping Screw
- ⑮ Install YAGI Or Omnidirectional Antenna
Per Contract Documents

DETAIL NO.
2398

City of Scottsdale
Standard Details

APPROVED BY:
Scottsdale Standards & Specifications Committee

ANTENNA MAST DETAIL

DETAIL NO.
2398

REVISED 4/25/07

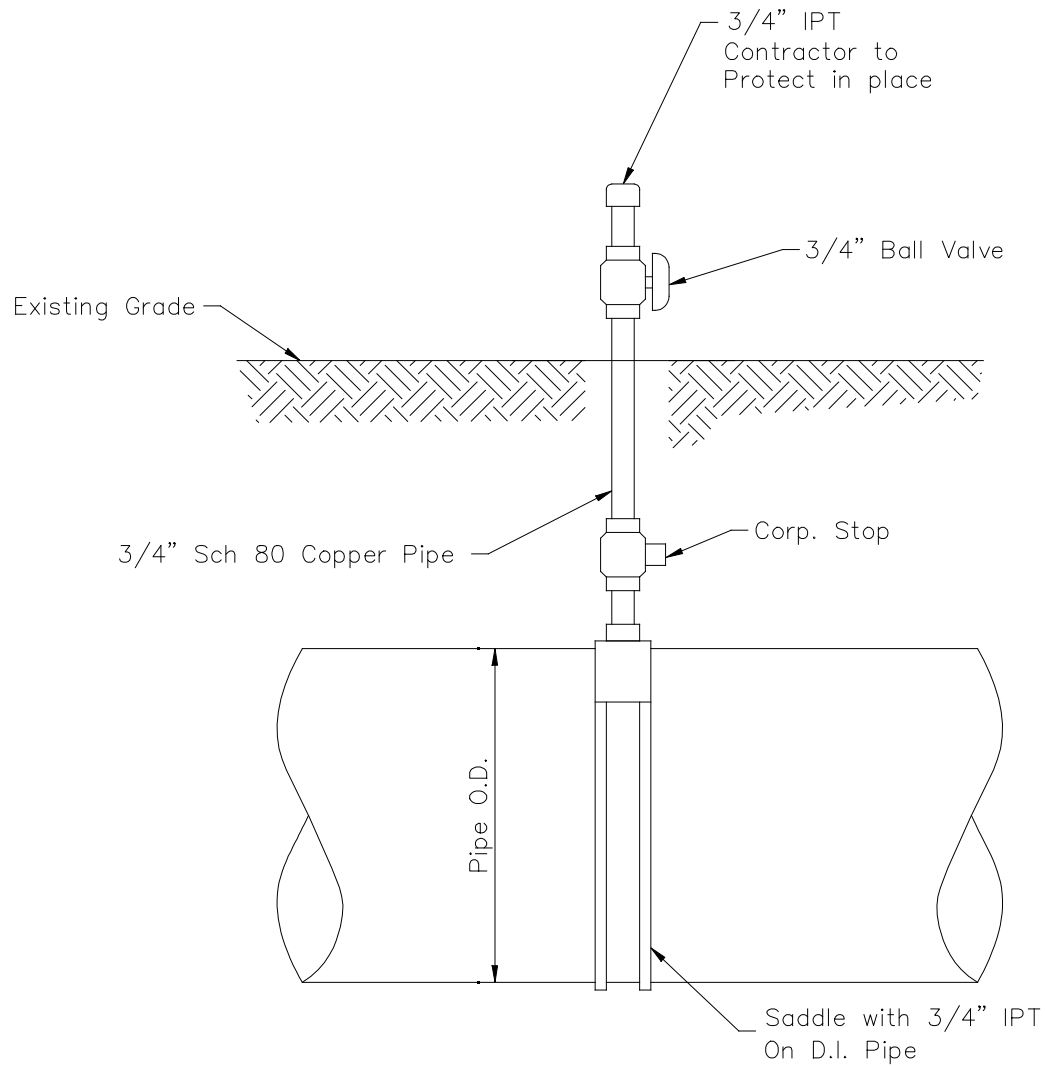

GENERAL NOTES:

1. Upon completion and acceptance of bacterial testing, the corp stop shall be shut off. The copper riser shall be disconnected and removed. The corp stop shall remain closed in place.

DETAIL NO.
2399

**City of Scottsdale
Standard Details**

APPROVED BY:
**Scottsdale Standards &
Specifications Committee**

TEMPORARY TAP FOR CHLORINE INJECTION

DETAIL NO.
2399

REVISED 3/25/09

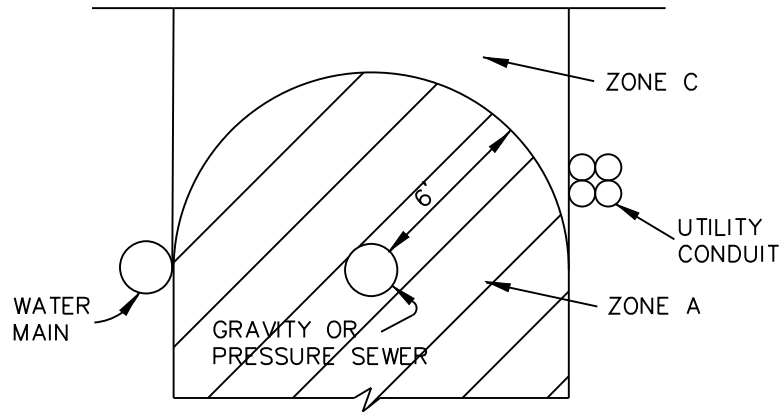

PARALLEL INSTALLATION GRAVITY OR PRESSURE SEWER

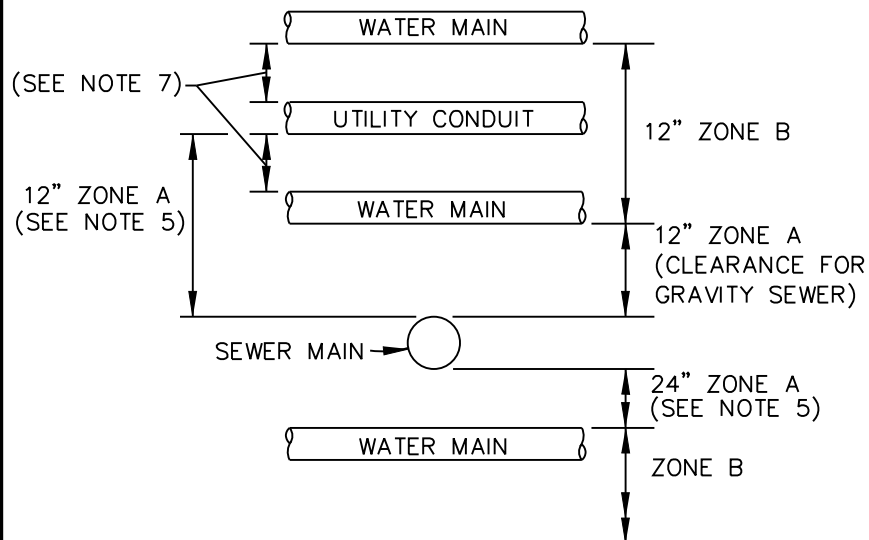

CROSSING INSTALLATION

NOTES:

1. SEPARATION DISTANCES AND/OR EXTRA PROTECTION SHALL BE REQUIRED TO PROTECT WATER MAINS FROM CONTAMINATION BY SANITARY SEWER MAINS.
2. SEE CROSS INSTALLATION DETAIL ON THIS SHEET FOR LIMITS OF SEPARATION/EXTRA PROTECTION. ALL DISTANCES ARE MEASURED PERPENDICULARLY FROM THE OUTSIDE OF THE PIPES.
 - A. NO WATER MAINS OR UTILITY CONDUITS SHALL FALL WITHIN ZONE A.
 - B. EXTRA PROTECTION WILL BE REQUIRED WHEN THE WATER MAIN FALLS WITHIN ZONE B. EXTRA PROTECTION SHALL CONSIST OF CONSTRUCTING SANITARY SEWER MAINS WITH MECHANICAL JOINT OR RESTRAINED JOINT DUCTILE IRON PIPE. DUCTILE IRON PIPE SHALL COMPLY WITH THE REQUIREMENTS FOR SEWER INSTALLATION. IN A CROSSING, THE NUMBER OF JOINTS SHALL BE HELD TO A MINIMUM WITH ONE FULL JOINT OF PIPE CENTERED OVER/UNDER THE OTHER. AN ALTERNATIVE PROTECTION MAY CONSIST OF ENCASING SEWER MAINS IN REINFORCED CONCRETE PER MAG STD. DETAIL 404-3.
 - C. NO ADDITIONAL PROTECTION WILL BE REQUIRED OUTSIDE OF ZONES A AND B.
 - D. WATER MAINS PERMITTED IN ZONE C ONLY WITH WRITTEN PERMISSION FROM THE WATER RESOURCES DEPARTMENT.
3. SEPARATION REQUIREMENTS FOR 4" OR 6" INDIVIDUAL HOUSE SERVICE CONNECTIONS SHALL COMPLY WITH THE PLUMBING CODES ADOPTED BY THE CITY.
4. RECLAIMED WATER SHALL BE CONSIDERED AS POTABLE WATER WHEN PLACED NEXT TO A SANITARY SEWER AND CONSIDERED A PRESSURE OR FORCED SANITARY SEWER MAIN, WHEN PLACED NEXT TO A POTABLE WATER MAIN.
5. ZONE A IS 24" WHERE WATER MAINS AND UTILITY CONDUITS CROSS PRESSURE SEWER MAINS.
6. THIS DRAWING REVISES MAG STD. DETAIL 401-1 ONLY. MAG STD. DETAILS 404-2 & 404-3 REMAIN INTACT.
7. REFERENCE COS STANDARD DETAIL 2370 AND 2372.

DETAIL NO.
2401

**City of Scottsdale
Standard Details**

APPROVED BY:
**Scottsdale Standards &
Specifications Committee**

**SANITARY SEWER SEPARATION / PROTECTION
FROM WATER & UTILITIES**

DETAIL NO.
2401

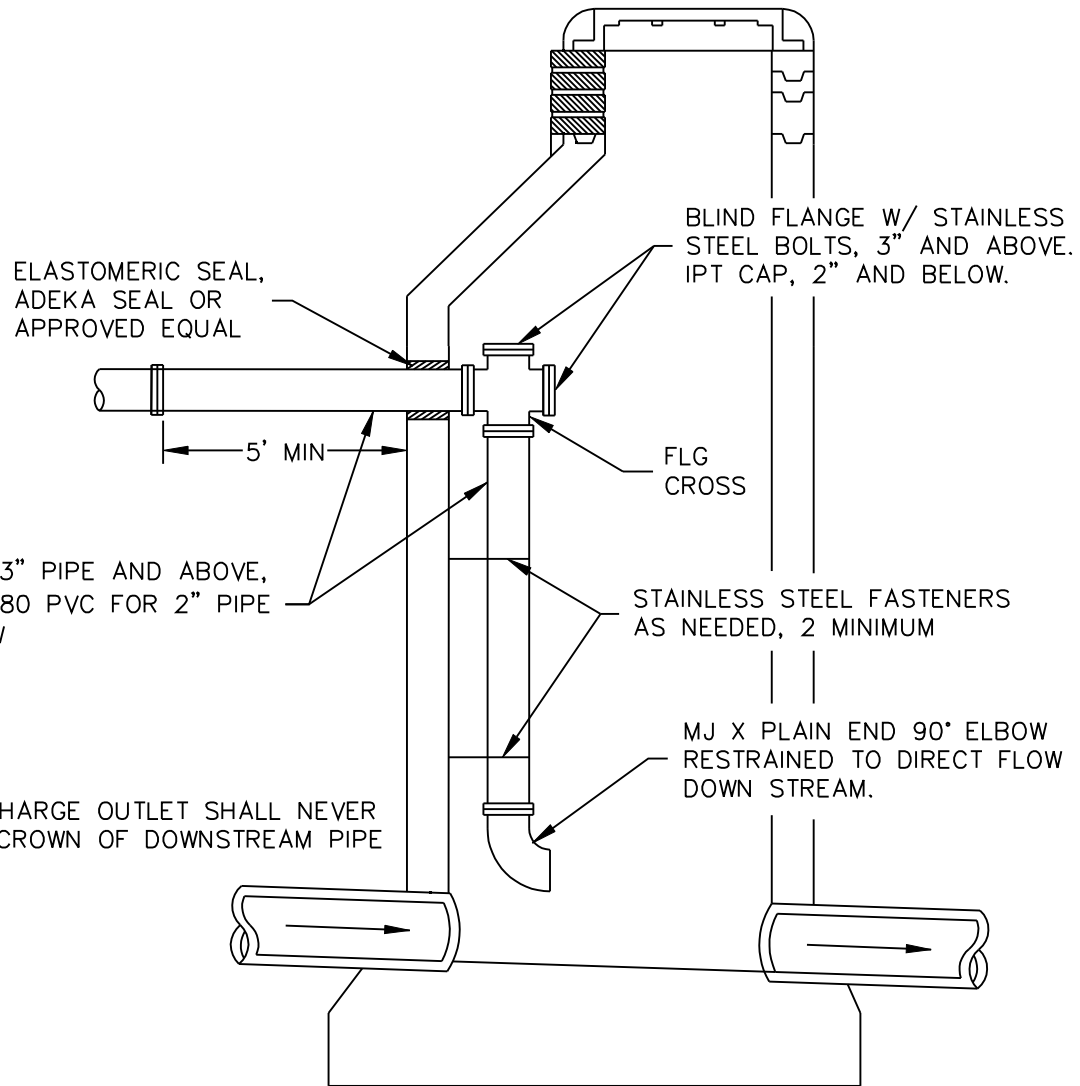

D.I.P. FOR 3" PIPE AND ABOVE,
 SCHEDULE 80 PVC FOR 2" PIPE
 AND BELOW

NOTE: DISCHARGE OUTLET SHALL NEVER
 BE BELOW CROWN OF DOWNSTREAM PIPE

BLIND FLANGE W/ STAINLESS
 STEEL BOLTS, 3" AND ABOVE.
 IPT CAP, 2" AND BELOW.

FLG
 CROSS

STAINLESS STEEL FASTENERS
 AS NEEDED, 2 MINIMUM

MJ X PLAIN END 90° ELBOW
 RESTRAINED TO DIRECT FLOW
 DOWN STREAM.

DETAIL NO.
2402

**City of Scottsdale
 Standard Details**

APPROVED BY:
**Scottsdale Standards &
 Specifications Committee**

FORCE MAIN DISCHARGE MANHOLE

DETAIL NO.
2402

REVISED 4/06/09

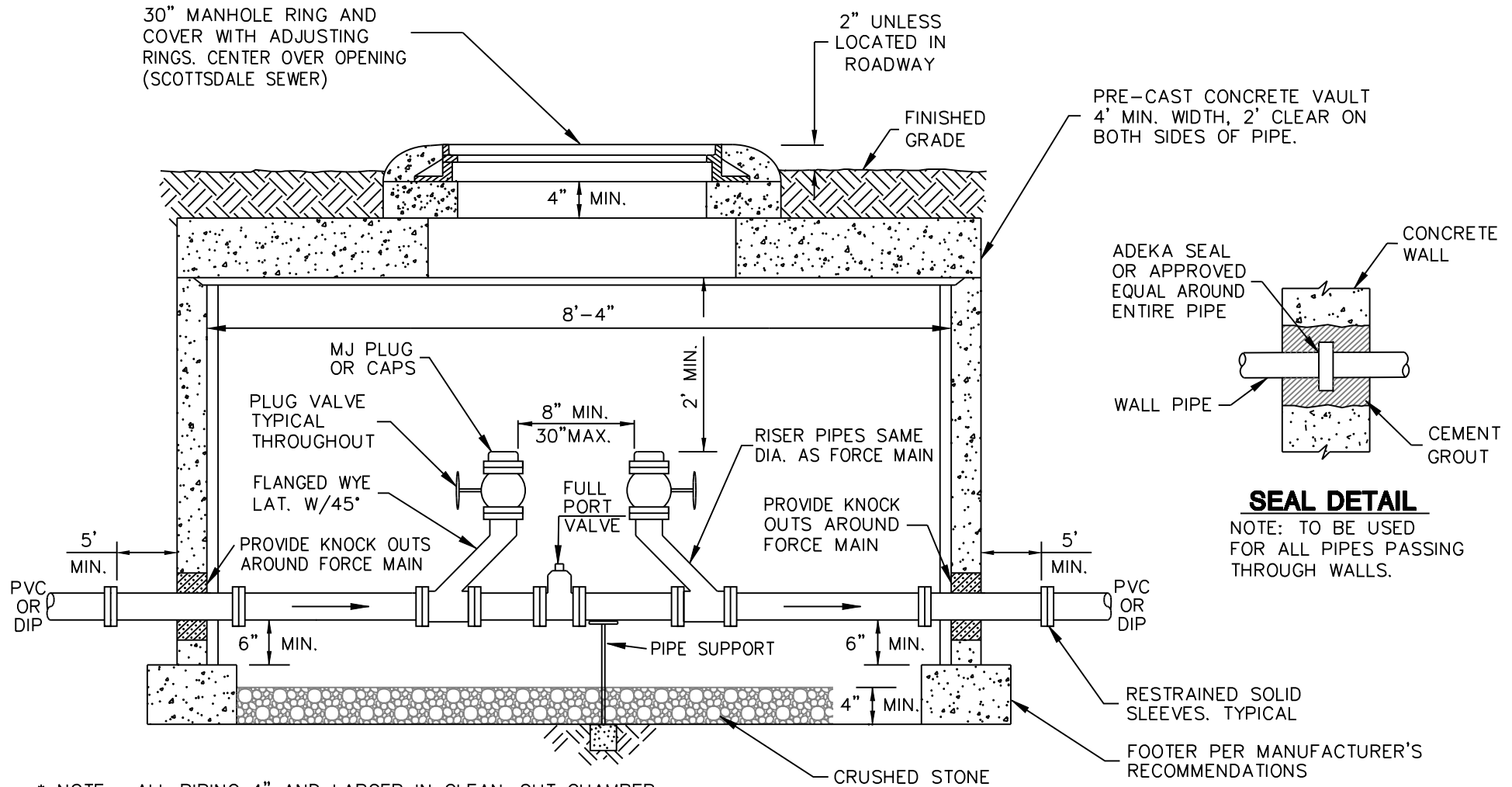

* NOTE: ALL PIPING 4" AND LARGER IN CLEAN-OUT CHAMBER, EXCEPT AS NOTED, TO BE DUCTILE IRON CONNECTED WITH FLANGED JOINTS AND STAINLESS STEEL BOLTS.

DETAIL NO.
2403

City of Scottsdale
Standard Details

APPROVED BY:
Scottsdale Standards & Specifications Committee

TWO-WAY FORCE MAIN CLEAN-OUT

DETAIL NO.
2403

REVISED 4/15/09

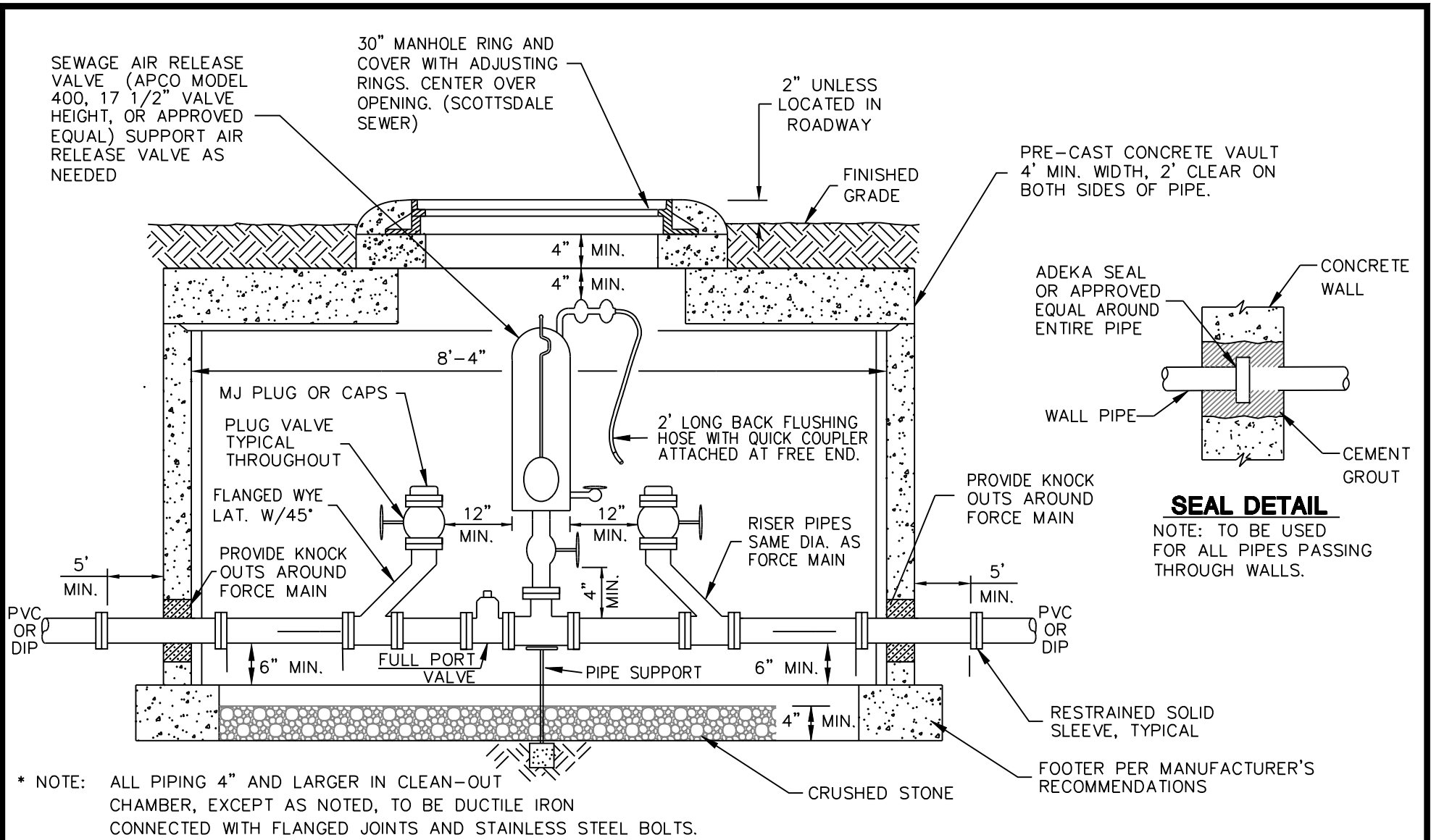

DETAIL NO. 2404

City of Scottsdale Standard Details

APPROVED BY: Scottsdale Standards & Specifications Committee

FORCE MAIN CLEANOUT WITH SEWAGE AIR RELEASE VALVE

DETAIL NO. 2404

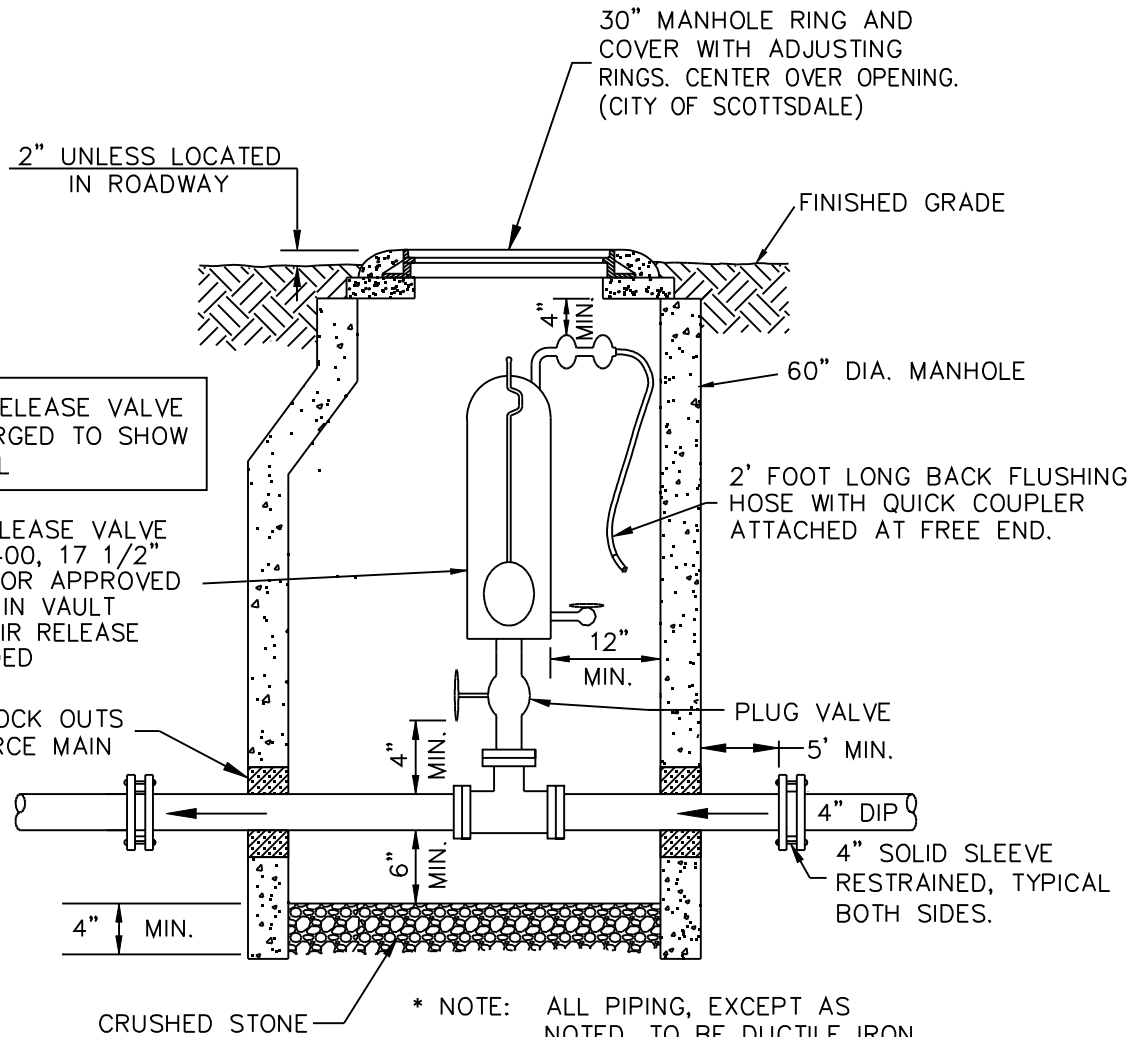

2" UNLESS LOCATED IN ROADWAY

AIR RELEASE VALVE ENLARGED TO SHOW DETAIL

SEWAGE AIR RELEASE VALVE (APCO MODEL 400, 17 1/2" VALVE HEIGHT, OR APPROVED EQUAL) CENTER IN VAULT AND SUPPORT AIR RELEASE VALVE AS NEEDED

30" MANHOLE RING AND COVER WITH ADJUSTING RINGS. CENTER OVER OPENING. (CITY OF SCOTTSDALE)

FINISHED GRADE

60" DIA. MANHOLE

2' FOOT LONG BACK FLUSHING HOSE WITH QUICK COUPLER ATTACHED AT FREE END.

12" MIN.

PLUG VALVE

5' MIN.

4" DIP

4" SOLID SLEEVE RESTRAINED, TYPICAL BOTH SIDES.

* NOTE: ALL PIPING, EXCEPT AS NOTED, TO BE DUCTILE IRON WITH FLANGE JOINTS AND STAINLESS STEEL BOLTS.

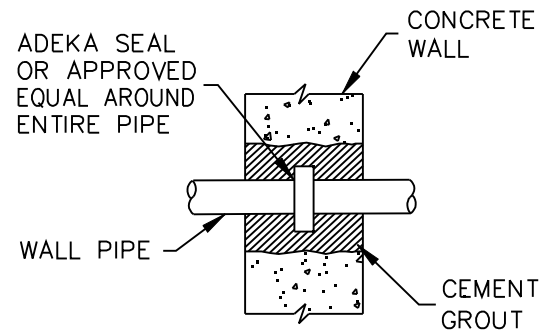

SEAL DETAIL

NOTE: TO BE USED FOR ALL PIPES PASSING THROUGH WALLS.

DETAIL NO. 2405

City of Scottsdale Standard Details

APPROVED BY: Scottsdale Standards & Specifications Committee

SEWER AIR RELEASE VALVE

DETAIL NO. 2405

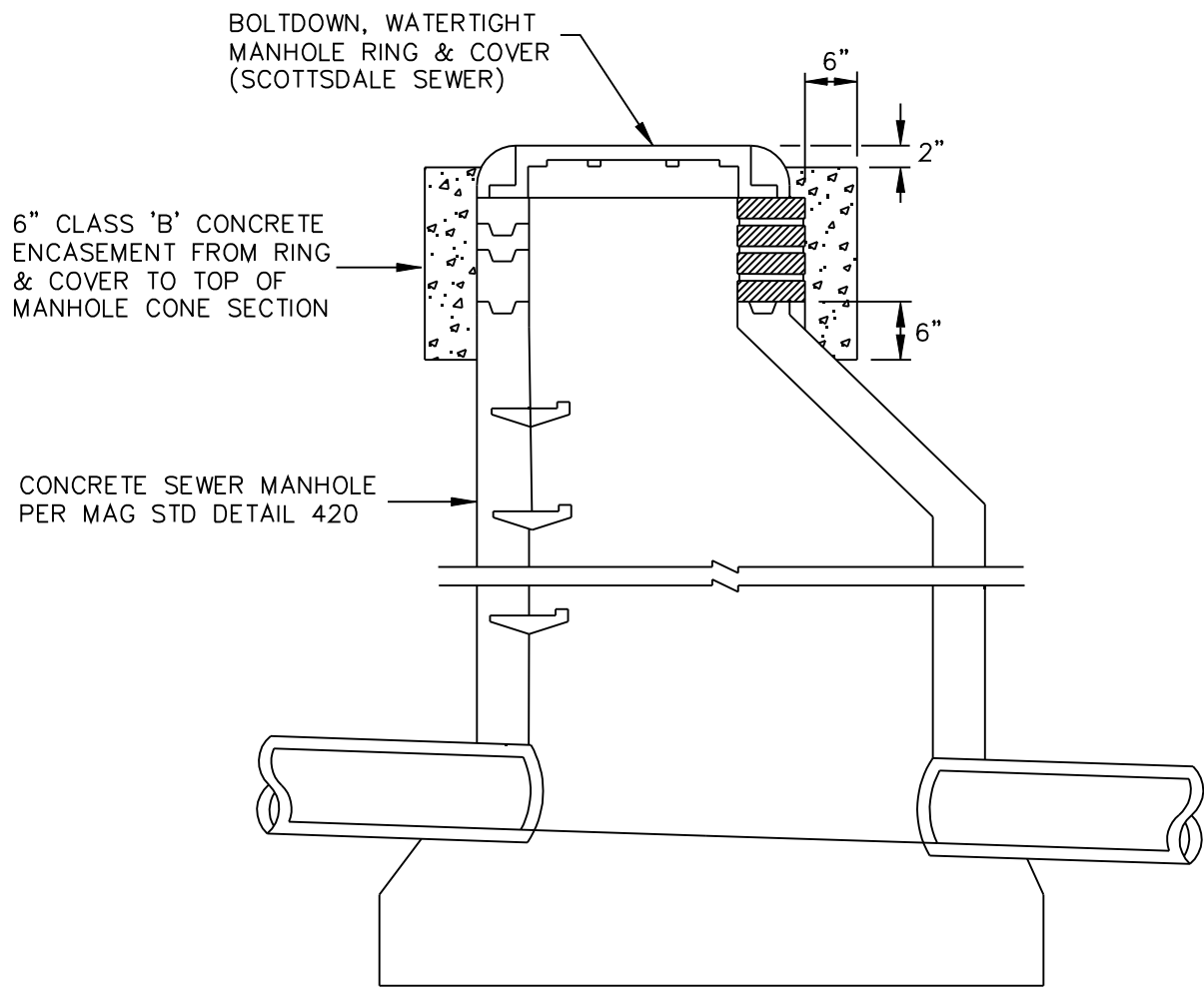

DETAIL NO.
2420

**City of Scottsdale
Standard Details**

APPROVED BY:
**Scottsdale Standards &
Specifications Committee**

WATER TIGHT CONCRETE SEWER MANHOLE

DETAIL NO.
2420

2" High Raised Letters

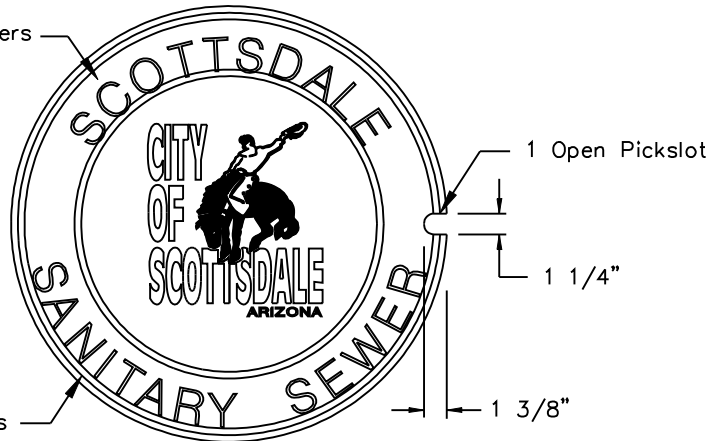

TOP VIEW

2" High Raised Letters

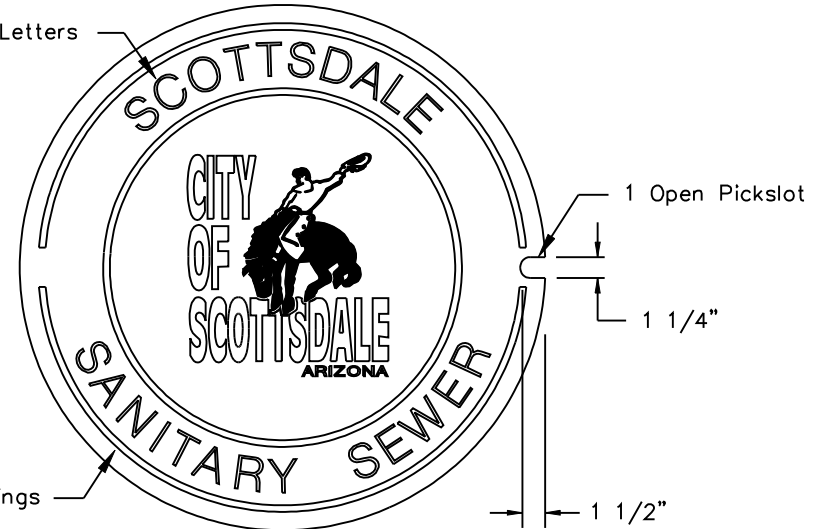

TOP VIEW

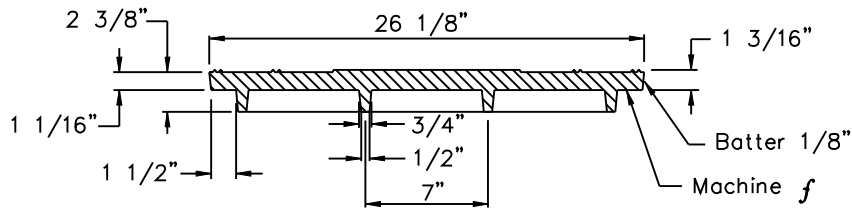

SECTION OF COVER

24" MANHOLE COVER

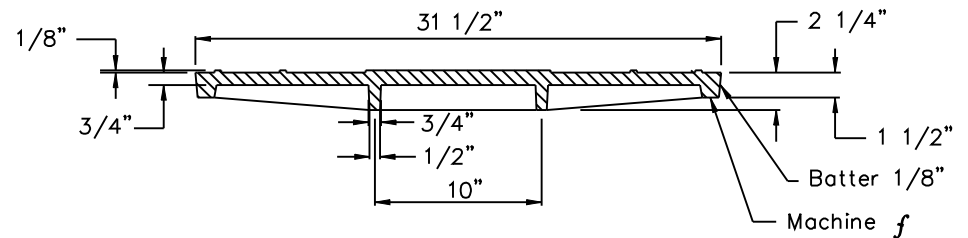

SECTION OF COVER

30" MANHOLE COVER

NOTES

1. Material: Cast Gray Iron ASTM A-48, Class 35B, Unpainted
2. The Total Width Of Individual Letters To Be Such That Letters And Words Are Equally Spaced And Balanced.
3. Letters To Be 2" In Height And Raised 1/8" Above Level Of Cover. Type Of Letters To Be Submitted For Approval.
4. Weight Of Castings Shall Be No More Than 2% Less Than Weight Specified. Castings Shall Conform To M.A.G. Section 787.

DETAIL NO.

2421

**City of Scottsdale
Standard Details**

APPROVED BY:

**Scottsdale Standards &
Specifications Committee**

SANITARY SEWER MANHOLE COVER

DETAIL NO.

2421

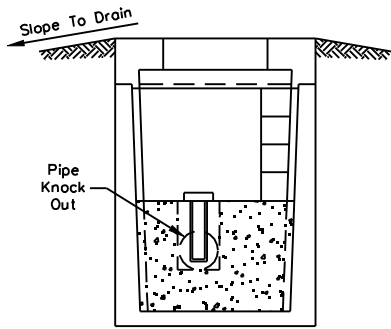

SECTION A-A

PRE-CAST VAULT

UTILITY VAULT CO.
VAULT NO. 575-BL,
NO. 577-BL OR
APPROVED EQUAL

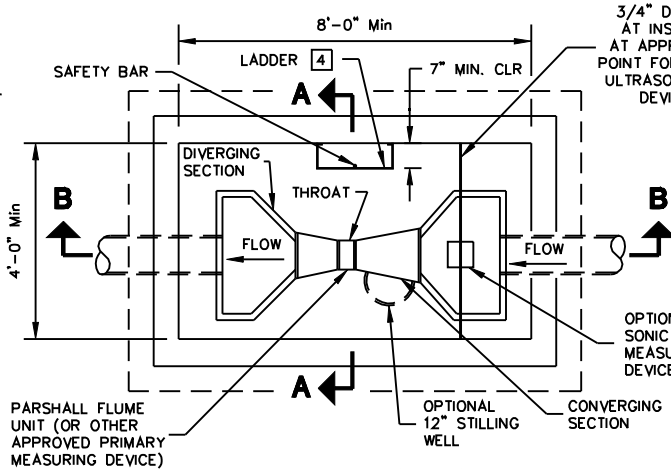

PLAN VIEW (TYP.)

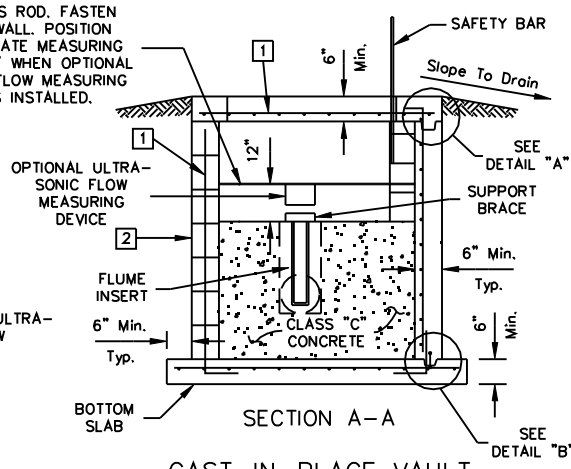

SECTION A-A
CAST-IN-PLACE VAULT

NOTES:

- 1 Reinforced steel and clearance as approved by the engineer.
- 2 Block masonry may be used in lieu of CIP walls. 8" block masonry, grout each cell to full height (grout per MAG Section 776).
- 3 2 Torsion spring assisted galvanized diamond plate access doors (design loading AASHO-H20) locking with type 304SS hardware and safety bar (Bilco Model LU-3, or approved equal).
- 4 Ladder shall be furnished and installed in accordance with the detail and shall meet the requirements of OSHA for Type IA (300 lbs) fixed ladders, single section. Details of ladder construction, along with a certification that the ladder meets or exceeds OSHA requirements for Type IA (300 lbs) service shall be submitted for review prior to furnishing and installing. Mill finished aluminum ladder or approved corrosion resistant material.
- 5 2"x 4" key, center on wall. (Install rope caulk continuously).
- 6 1-5/8"x 2-1/2"x 3" key.
- 7 4" PVC dumbbell type continuous waterstop 3/8" min. thickness. (Wash thoroughly prior to installation).
- 8 Anchor straps (3 each side) with 5/8" x 3-1/2" 316SS anchor bolts with lock washer and nut.

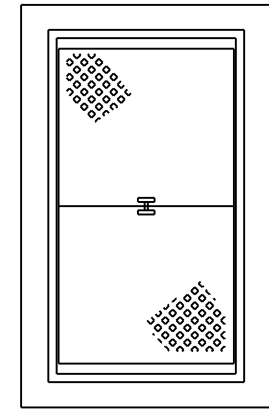

COVER WITH LID

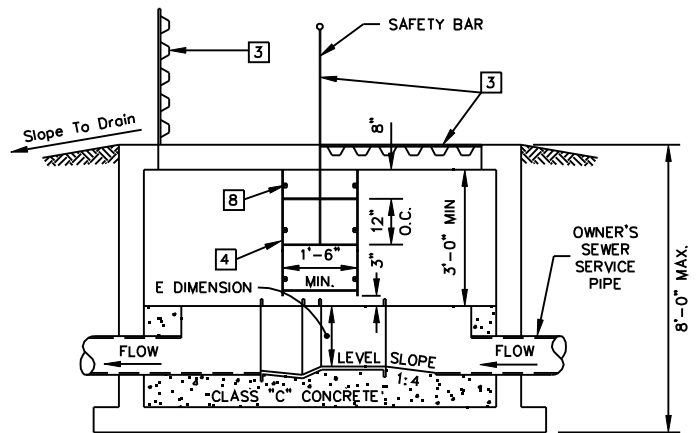

SECTION B-B

EQUIPMENT DESCRIPTION

A Fisher and Porter type 10F1940, Hinde Engineering Company, PS-1001, or approved equal molded fiberglass reinforced polyester Parshall Flume shall be installed. The flume shall be molded in one piece with ample wall thickness and reinforcing ribs to prevent distortion during shipment, installation and operation. The flume shall be self-supporting and require no external supporting structure. Interior dimensions shall conform to those in the latest revision of Water Measurement Manual published by the U.S. Department of the Interior, Water and Power Resources Services. The throat width and flume height (E dimension) shall be per plan.

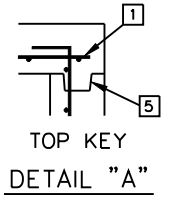

TOP KEY
DETAIL "A"

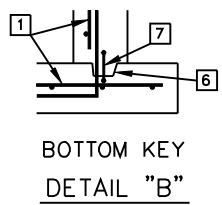

BOTTOM KEY
DETAIL "B"

GENERAL NOTES

1. All construction shall conform to MAG Specifications and Details and City of Scottsdale Supplement to MAG Specifications and Details, unless modified on the plans.
2. All concrete floors, walls and top slab of the structure shall conform to MAG section 725, Class A, minimum compressive strength at 28 days = 3,000 psi.
3. All concrete for the grout fillet inside the structure shall conform to MAG Section 725, Class C, minimum compressive strength at 28 days = 2,000 psi.
4. All steel reinforcing shall be deformed bars, Grade 60, billet steel conforming to ASTM Specification No. A-615, latest edition.
5. The Monitoring/Sampling Vault shall be installed on the owner's property as close to the customer top to the City sewer as feasible, and approved by the City of Scottsdale.
6. Flume size should be based upon the minimum and maximum flow rates and velocities to insure free-flow conditions.
 - Maximum Flow = 70%-100% of maximum capacity of selected flume size.
 - 0.5 inches of flow should exist at the minimum actual flow.
7. Flume floor elevation should be high enough, relative to downstream conditions, to prevent submerged flow (50% submergence is acceptable at maximum flow), install the flume level (longitudinally and transversely) in the converging section.
8. Upstream flow should be wave free, non-turbulent, and symmetrical having a uniform velocity (1fps minimum to 3 fps maximum) at least 10 times the diameter of the upstream sewer pipe in length in the approach channel. Bends upstream in the flume will NOT be allowed for a distance of 25 pipe diameters unless conditions in the approach section of the flume will not be adversely affected.
9. The flume shall be installed off-center and away from the ladder to allow the maximum working space for City personnel.
10. It shall be the owner's responsibility to properly maintain the flume in accordance with the manufacturers recommendations to ensure the accuracy of the measurement.

DETAIL NO.
2460

**City of Scottsdale
Standard Details**

APPROVED BY:
**Scottsdale Standards &
Specifications Committee**

MONITORING/SAMPLING VAULT

DETAIL NO.
2460

REVISED 12/5/11

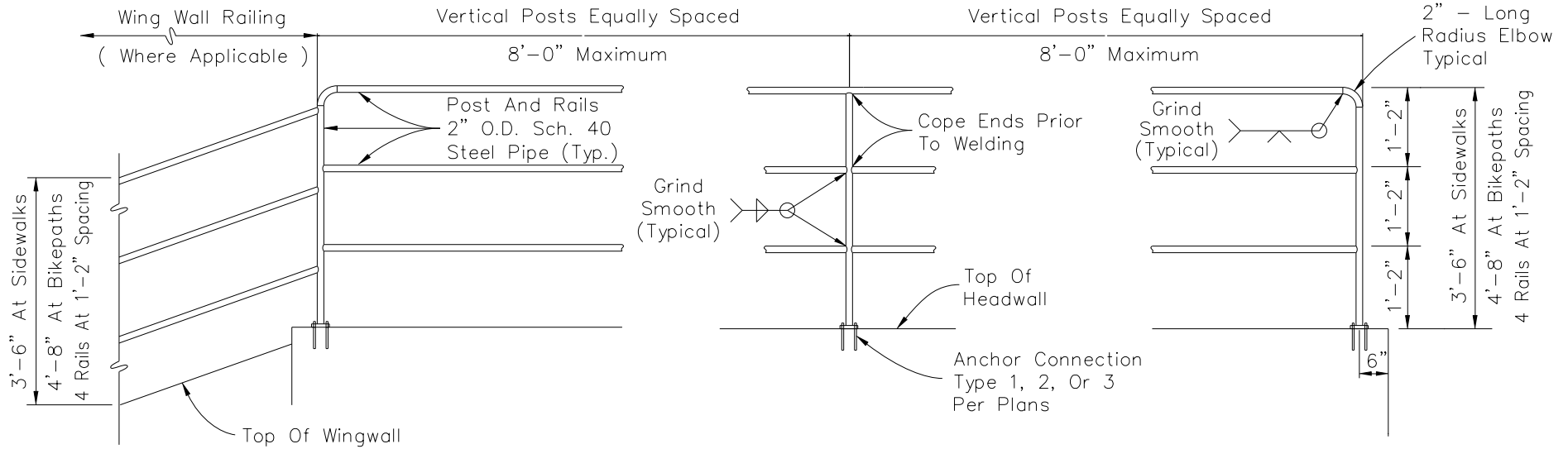

ELEVATION

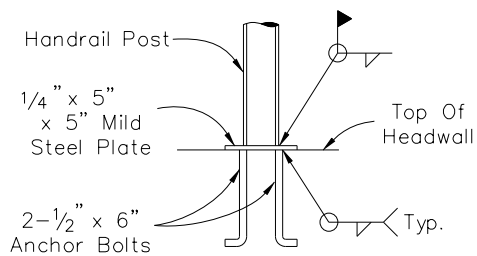

TYPE 1
ANCHOR PLATE DETAIL

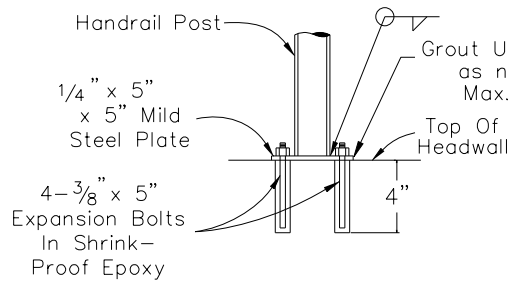

TYPE 2
EXPANSION BOLT DETAIL

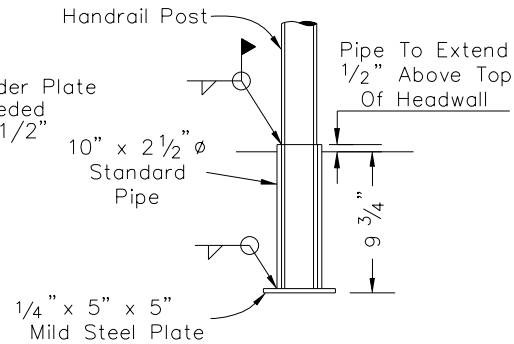

TYPE 3
PIPE SLEEVE DETAIL

CONSTRUCTION NOTES

1. Paint handrail per MAG Specifications Section 530. Color per plans.
2. Vertical posts to be evenly spaced.

DETAIL NO.
2508

**City of Scottsdale
Standard Details**

APPROVED BY:
**Scottsdale Standards &
Specifications Committee**

HANDRAIL DETAIL

DETAIL NO.
2508

REVISED 3/15/10

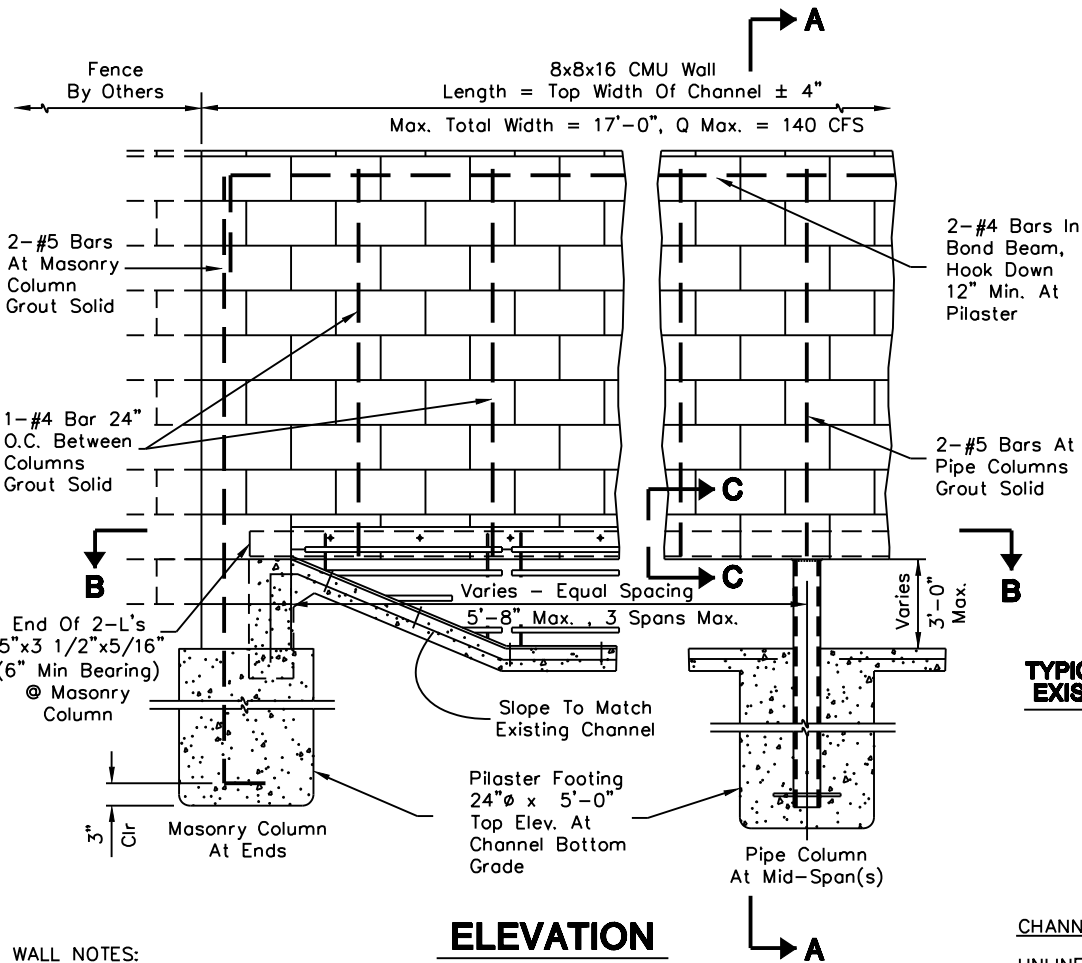

WALL NOTES:

1. Wall Height, Finish Texture And Color to Match Adjacent Property Wall.
2. Construction To Conform to MAG Section 510.
3. Trash Rack Grate Required on Private Lots only; And Property Owner Shall Be Responsible for Cleaning.

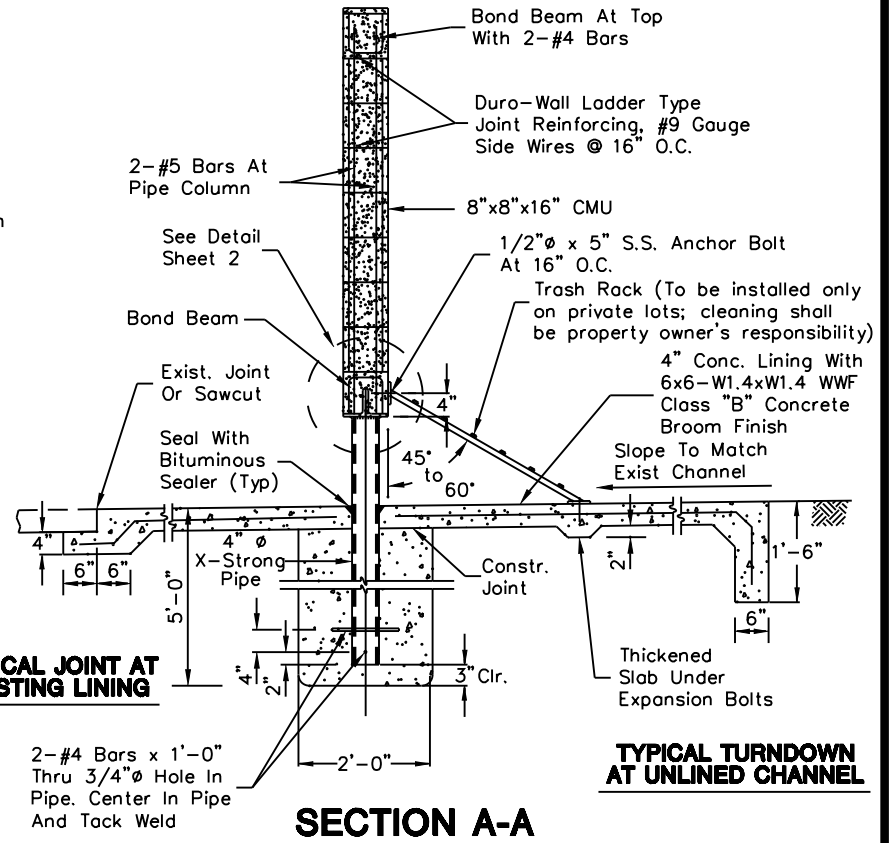

TYPICAL JOINT AT EXISTING LINING

TYPICAL TURNDOWN AT UNLINED CHANNEL

CHANNEL NOTES:

- UNLINED CHANNELS: Construct New Lining 6' Minimum Upstream And Downstream From Wall With Turndown At All Edges Of Lining.
- EXISTING LINED CHANNELS: Remove Existing Lining 4' Minimum Upstream And Downstream From Wall. Replace Using Joint Shown.

REVISED 3/15/10

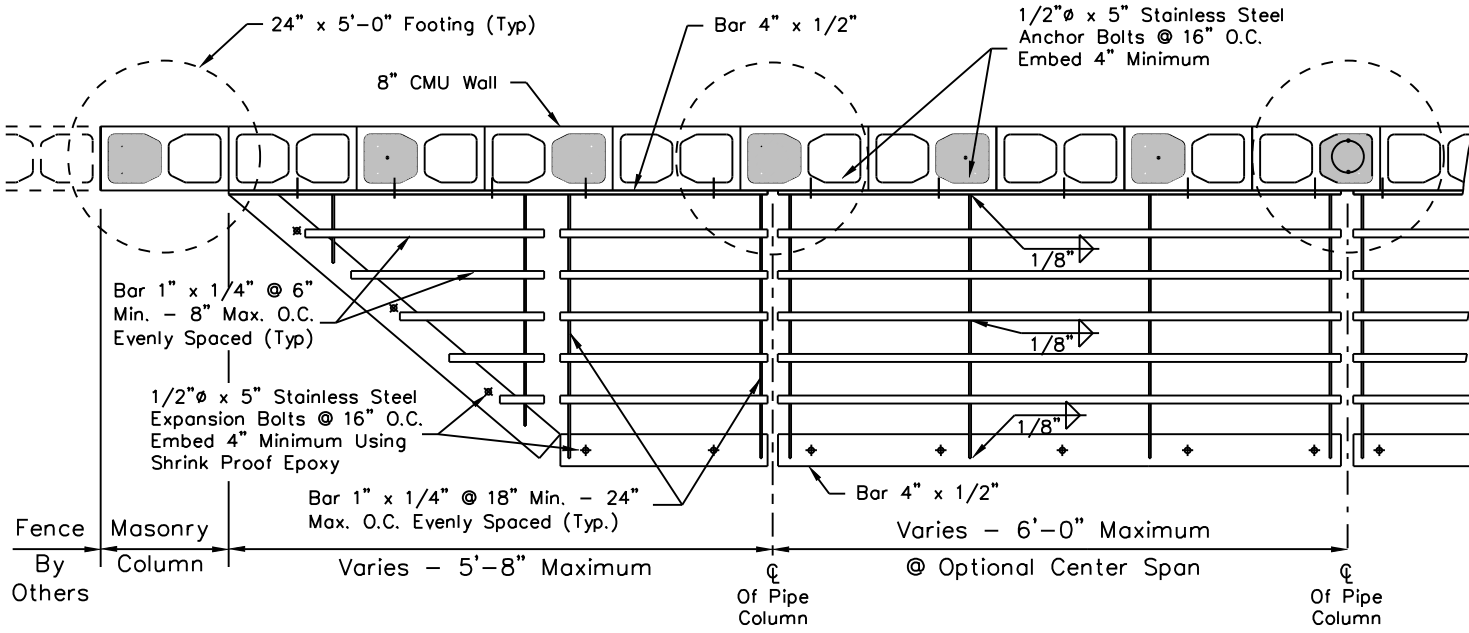

SECTION B-B

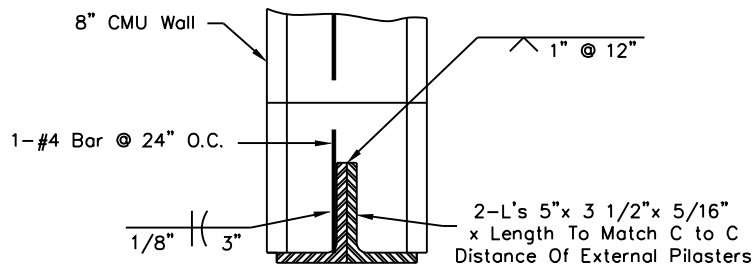

SECTION C-C

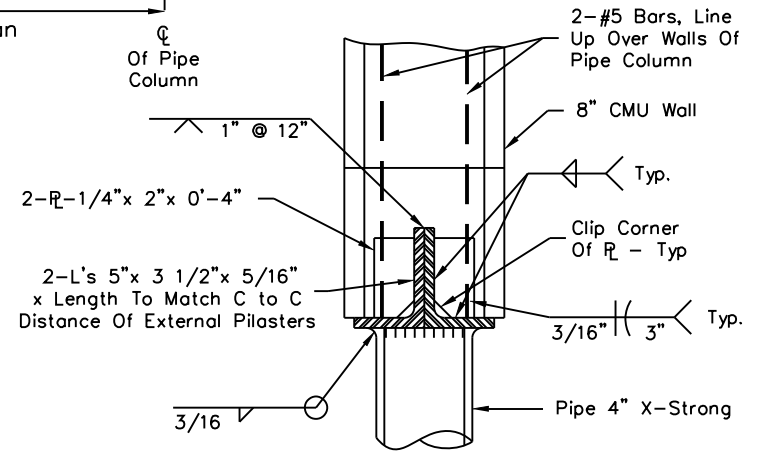

DETAIL AT PIPE COLUMN

GRATE NOTES:

1. Steel Work Shall Conform To Mag Sections 515 And 770.
2. Shop Drawings Are Not Required. Contractor Shall Be Responsible For Correct Fit Between The Trash Rack, Channel And Wall As Constructed In The Field.
3. Shop Prime Steel And Touch-Up Per MAG Section 515.5. Apply A Second Coat After Erection And A Finish Coat Of Alkyd Enamel To Match Wall Finish Color.
4. Grate Required on Private Lots Only. Property Owner Responsible for Cleaning.

DETAIL NO.
2515-2

**City of Scottsdale
Standard Details**

APPROVED BY:
**Scottsdale Standards &
Specifications Committee**

DRAINAGE GRATE AT BLOCK WALL

SHEET 2 OF 3
DETAIL NO.
2515-2

REVISED 12/21/11

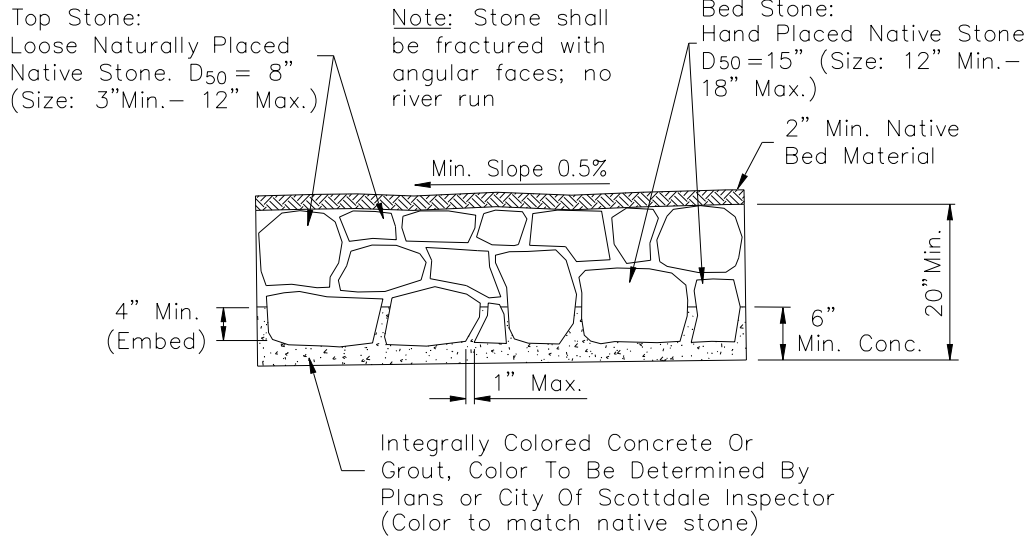

TYPE 2A - BURIED GROUDED RIP-RAP DETAIL

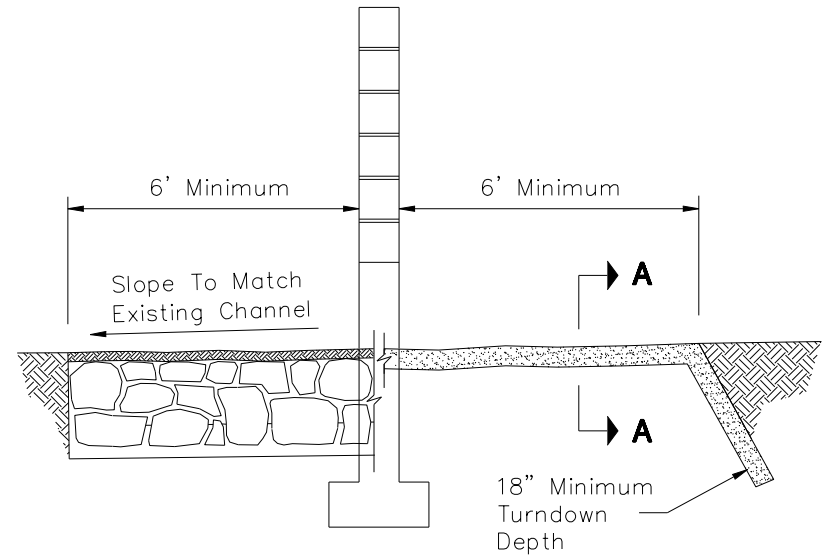

SECTION AT WALL

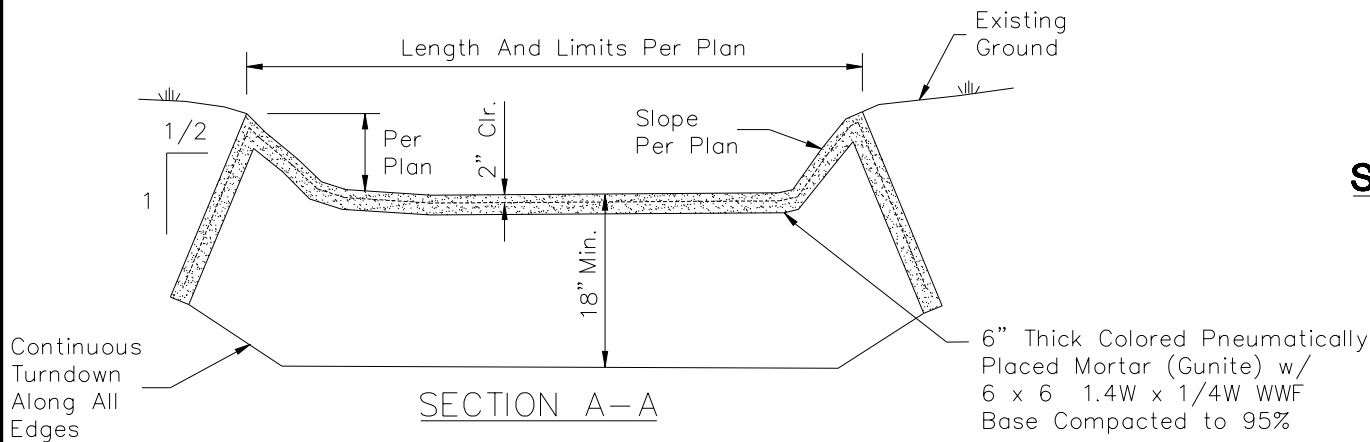

SECTION A-A

TYPE 2B - PNEUMATICALLY PLACED MORTAR DETAIL

SHEET 3 OF 3

DETAIL NO.
2515-3

**City of Scottsdale
Standard Details**

APPROVED BY:
**Scottsdale Standards &
Specifications Committee**

EROSION PROTECTION - TYPE 2

DETAIL NO.
2515-3

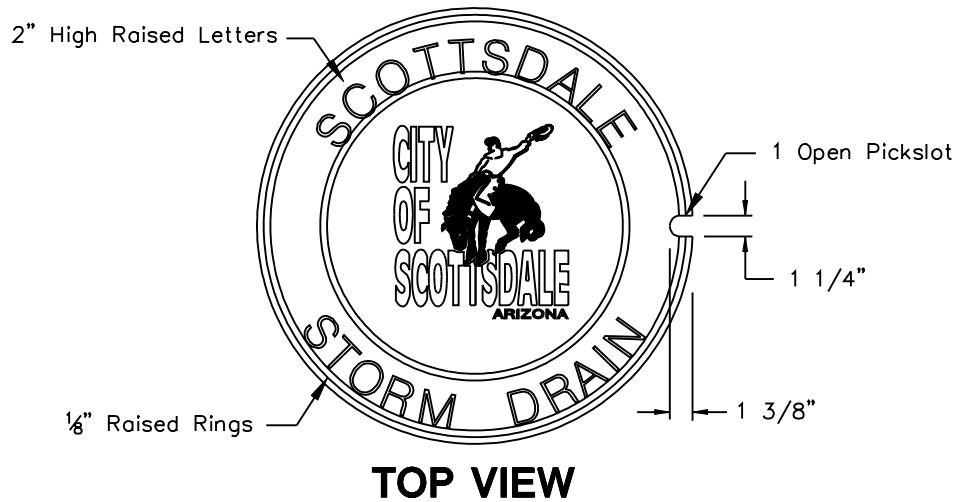

TOP VIEW

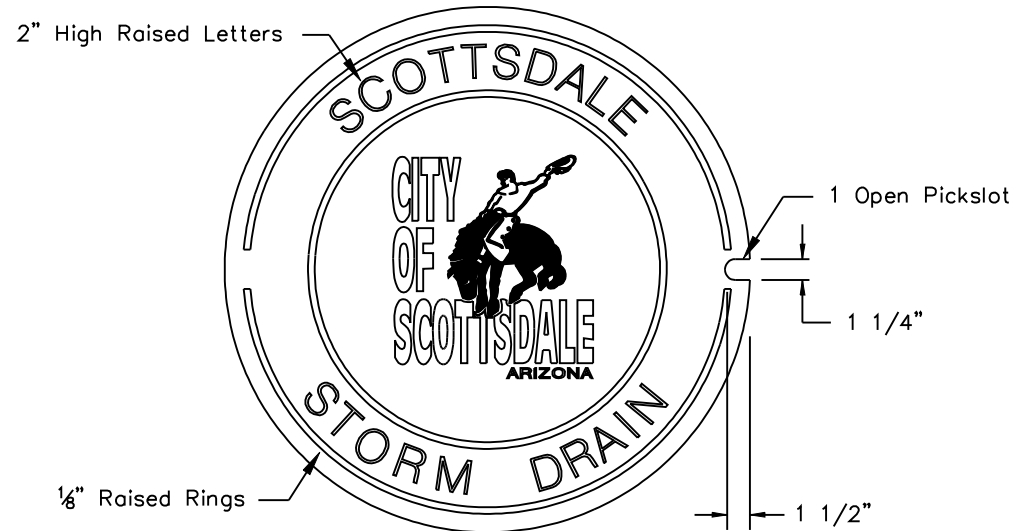

TOP VIEW

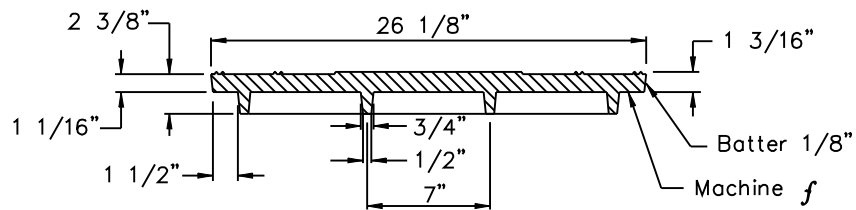

SECTION OF COVER

24" MANHOLE COVER

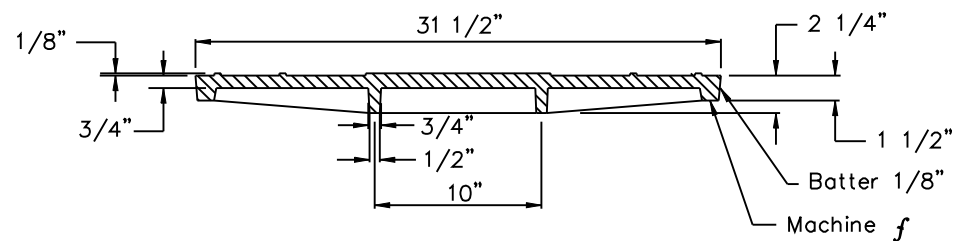

SECTION OF COVER

30" MANHOLE COVER

NOTES

1. Material: Cast Gray Iron ASTM A-48, Class 35B, Unpainted
2. The Total Width Of Individual Letters To Be Such That Letters And Words Are Equally Spaced And Balanced.
3. Letters To Be 2" In Height And Raised $\frac{1}{8}$ " Above Level Of Cover. Type Of Letters To Be Submitted For Approval.
4. Weight Of Castings Shall Be No More Than 2% Less Than Weight Specified. Castings Shall Conform To M.A.G. Section 787.

DETAIL NO. **2520** **City of Scottsdale Standard Details** APPROVED BY: **Scottsdale Standards & Specifications Committee**

STORM DRAIN MANHOLE COVER

DETAIL NO. **2520**

REVISED 4/15/09

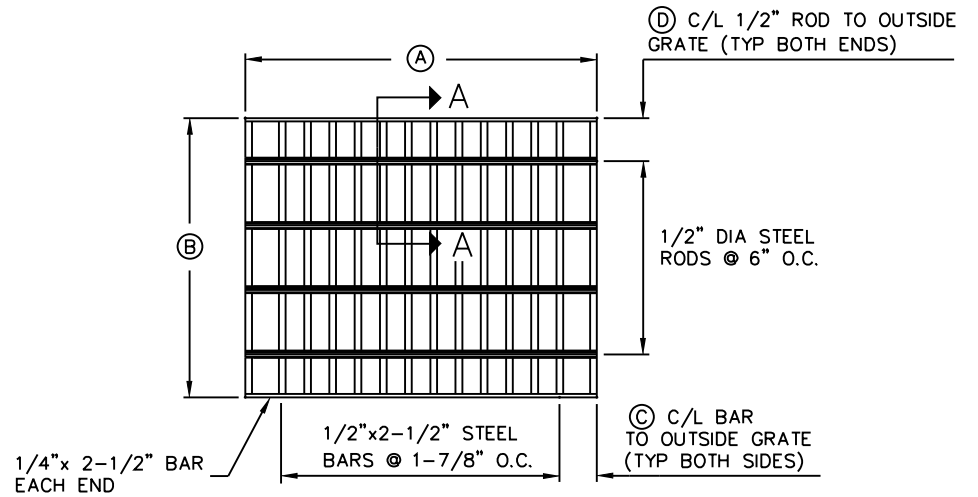
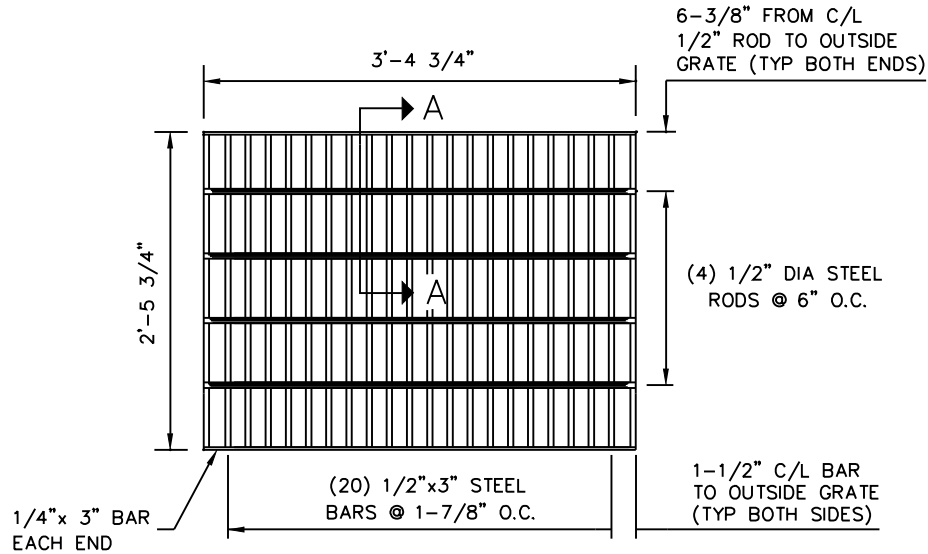

GRATE FOR TYPE "F" CATCH BASIN
REPLACES GRATE SHOWN IN MAG STD. DETAIL 535

GRATE FOR TYPE "G" & "H" CATCH BASINS
REPLACES GRATE SHOWN IN MAG STD. DETAILS 537/539

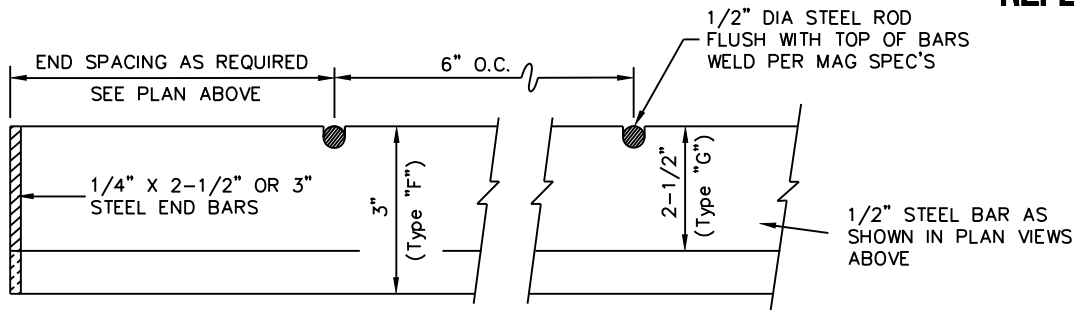

SECTION A-A

NOTES:

1. ALL MATERIALS AND FABRICATION TO BE AS SPECIFIED IN MAG STANDARD DETAIL NO. 540-2.
2. MAXIMUM TOTAL DIMENSION BETWEEN OUTSIDE OF GRATE AND INSIDE OF FRAME SHALL NOT EXCEED 3/8".

TYPE "G" GRATE DIMENSIONS		
	SINGLE GRATE	DOUBLE GRATE
①	2'-2"	4'-3 1/2"
②	2'-2"	2'-2"
③	2-11/16"	2-5/16"
④	0'-4"	0'-3 3/4"

DETAIL NO.
2535

City of Scottsdale
Standard Details

APPROVED BY:
Scottsdale Standards & Specifications Committee

CATCH BASIN GRATES

DETAIL NO.
2535

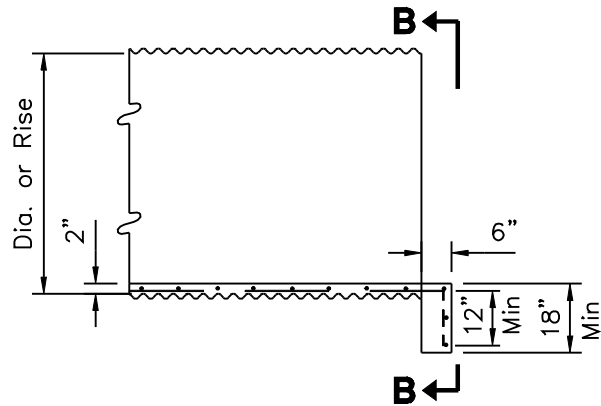

NO HEADWALL

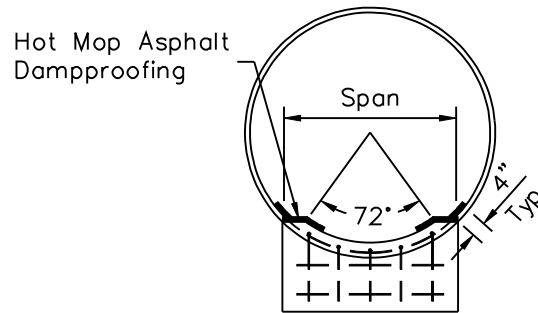

ELEVATION B-B

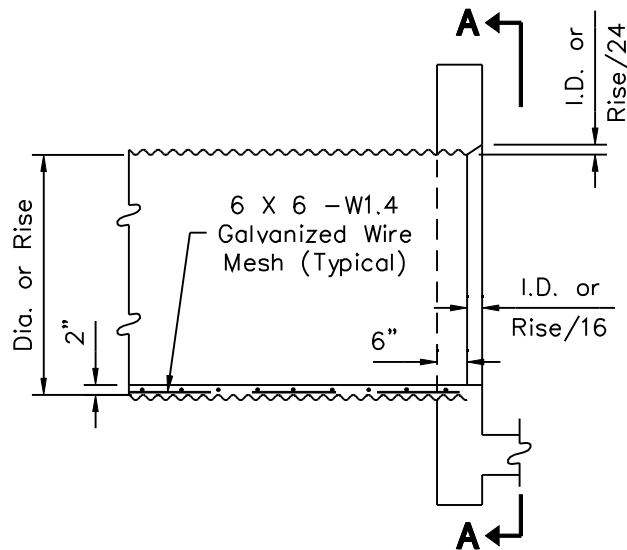

WITH HEADWALL

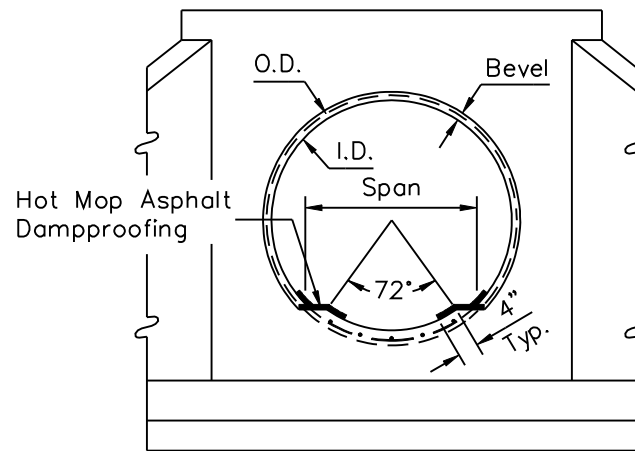

ELEVATION A-A

GENERAL NOTES

1. For lateral dimensions of invert paving, use 72° control for CMP and span for CMPA.
2. Paving shall be scored at 18" min. (transverse) along pipe length.
3. Use bevel on inlet headwall only.
4. Wire mesh shall be tack welded to corrugation crests at 18" intervals. Laps shall be 6" min.
5. Paving shall not be placed until backfilling is completed.
6. Concrete shall be Class "B".

DETAIL NO.
2554

**City of Scottsdale
Standard Details**

APPROVED BY:
**Scottsdale Standards &
Specifications Committee**

**CONCRETE INVERT PAVING FOR
CORRUGATED METAL PIPE AND PIPE ARCH**

DETAIL NO.
2554

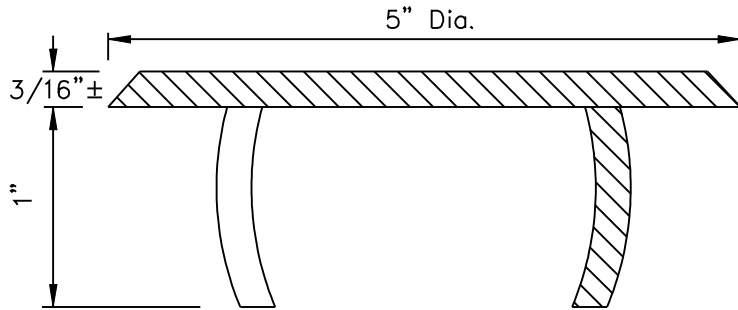

TYPE "A":

TO BE INSTALLED IN WET CONCRETE
DURING CONSTRUCTION

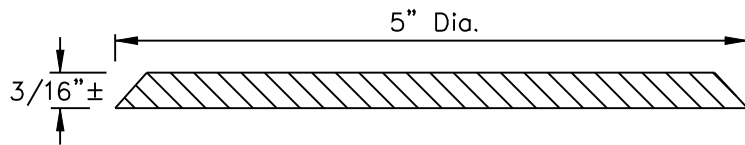

TYPE "B"

TO BE INSTALLED WITH ADHESIVE
ON EXISTING STRUCTURES



NOTES

1. Material: Cast Aluminum
2. The Total Width Of Individual Letters To Be Such That Letters And Words Are Equally Spaced And Balanced.
3. Letters To Be 1/2" In Height. Type Of Letters To Be Submitted For Approval.

DETAIL NO. **2560-1** **City of Scottsdale**
Standard Details

APPROVED BY:
Scottsdale Standards & Specifications Committee

STORM DRAIN INLET MARKER

DETAIL NO. **2560-1**

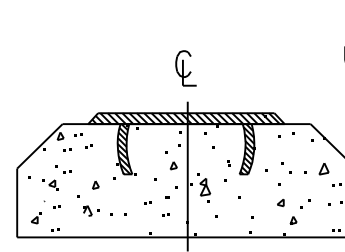
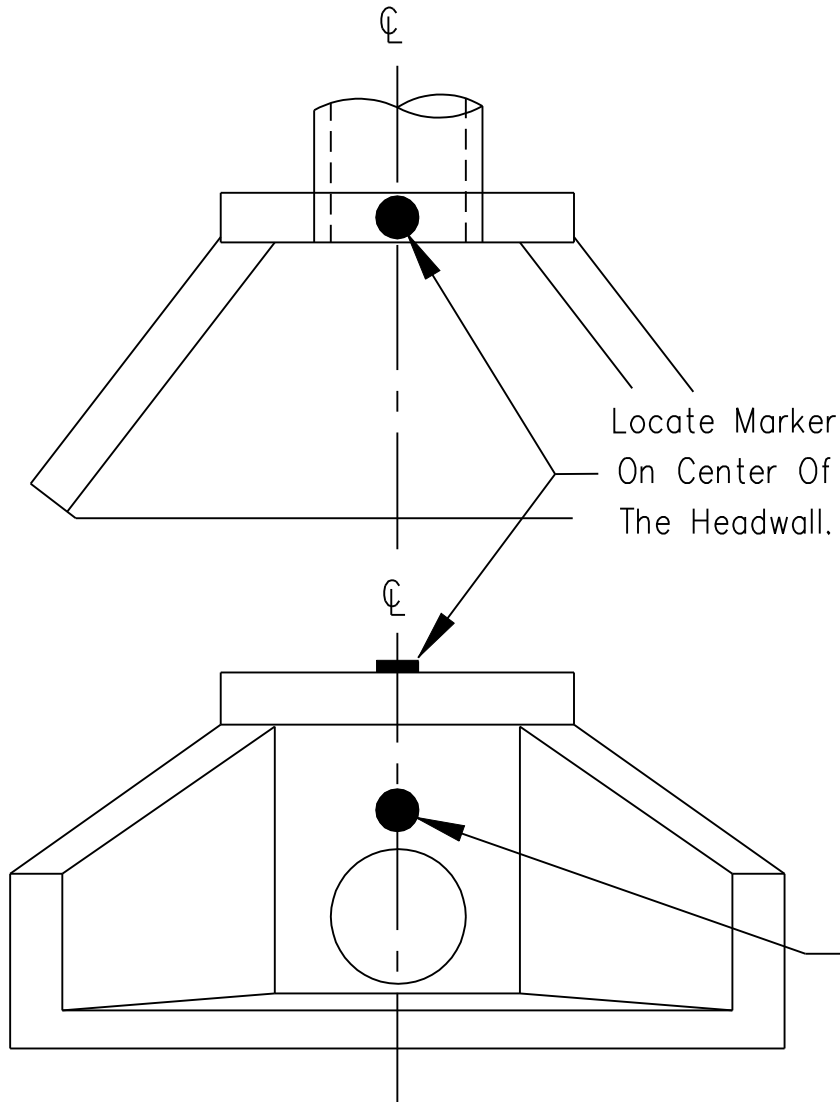

TYPE "A"
TO BE INSTALLED IN WET CONCRETE
DURING CONSTRUCTION

Dynamix #6125-1
Urethane Universal
Adhesive

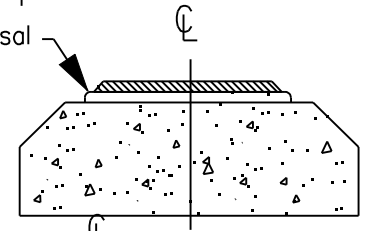

TYPE "B"
TO BE INSTALLED WITH ADHESIVE
ON EXISTING STRUCTURES

Locate Marker On the
Vertical Face Of Headwall
When Face Is 3' Or Greater.
Center On Headwall.

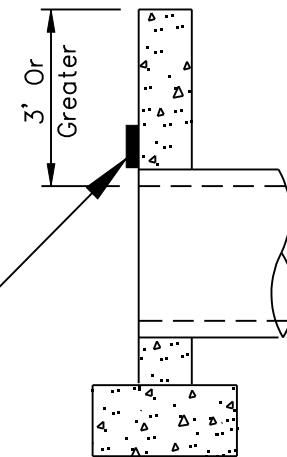

DETAIL NO.
2560-2

**City of Scottsdale
Standard Details**

APPROVED BY:
**Scottsdale Standards &
Specifications Committee**

STORM DRAIN INLET MARKER ON HEADWALL

DETAIL NO.
2560-2

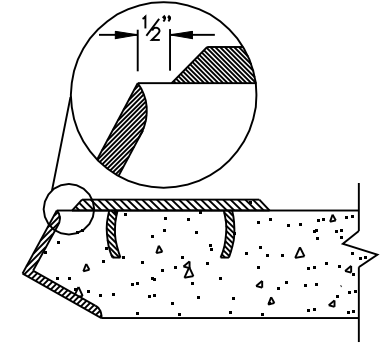
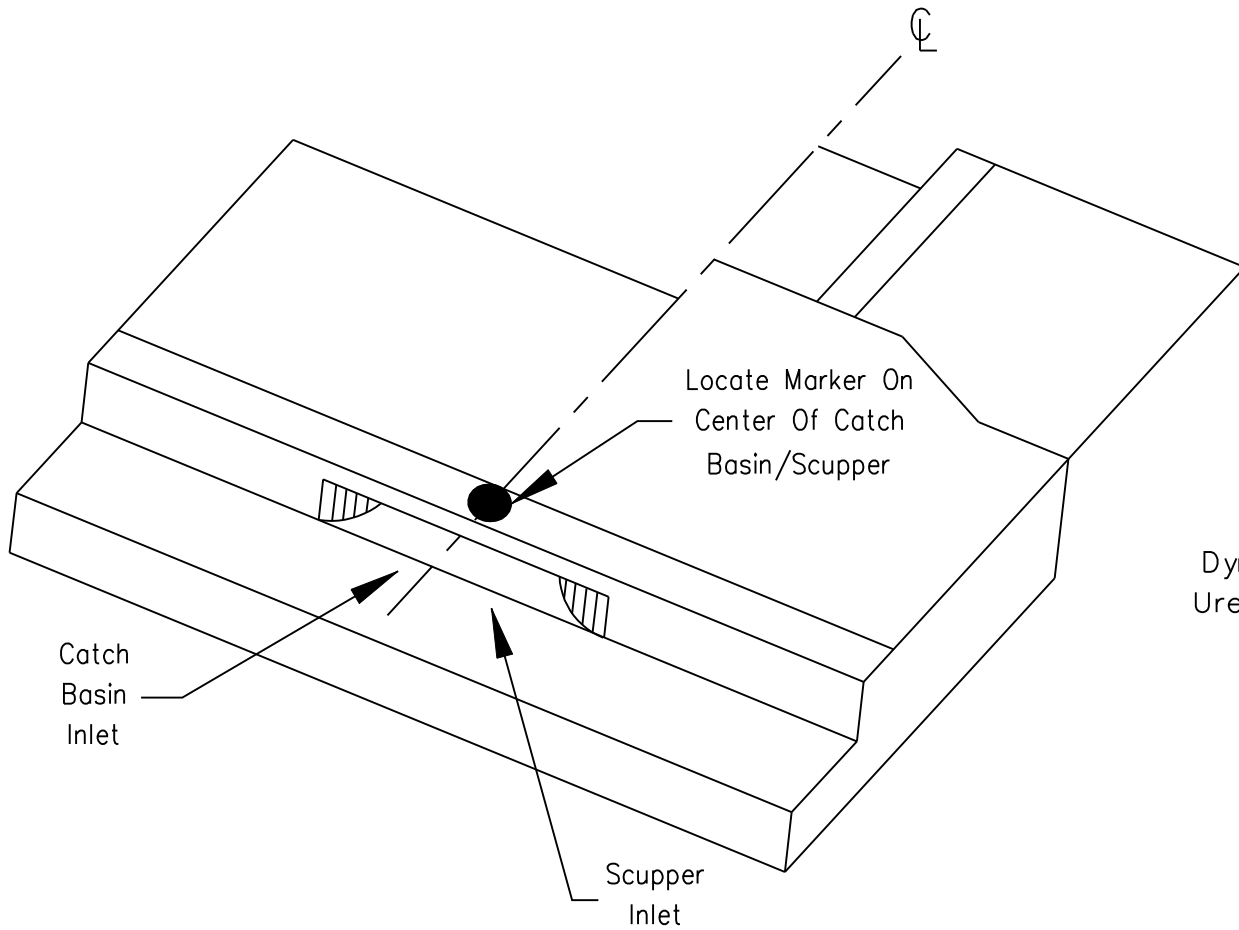

TYPE "A"

TO BE INSTALLED IN WET CONCRETE DURING CONSTRUCTION

Dynamix #6125-1 Urethane Universal Adhesive

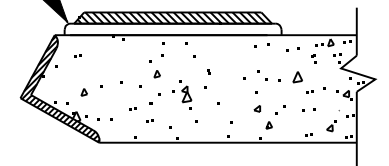

TYPE "B"

TO BE INSTALLED WITH ADHESIVE ON EXISTING STRUCTURES

DETAIL NO.

2560-3

**City of Scottsdale
Standard Details**

APPROVED BY:

**Scottsdale Standards &
Specifications Committee**

STORM DRAIN INLET MARKER ON CATCH BASIN/SCUPPER

DETAIL NO.

2560-3

REVISED 3/28/02

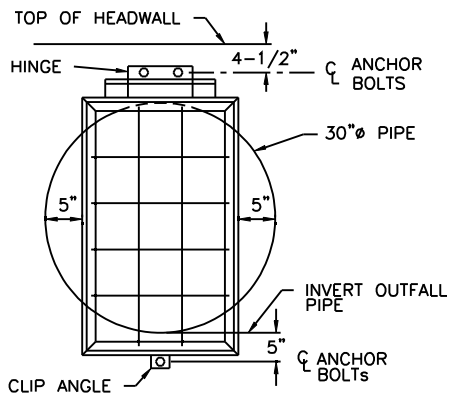

30"Ø & 36"Ø PIPES ONLY, SINGLE HINGE & CLIP ANGLE DETAIL

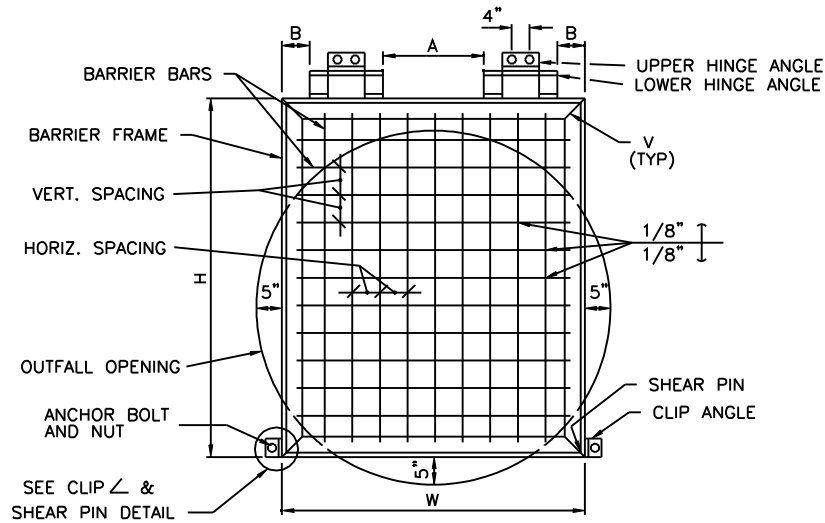

TYPICAL BARRIER DETAIL

NOTES:

1. ALL SHEAR PIN ANGLES SHALL FIT SNUGLY AND TRULY FACE TO FACE. COVER WITH WATERPROOF GREASE PRIOR TO INSTALLATION OF PIN.
2. GALVANIZE ALL FERROUS PARTS AFTER FABRICATION.
3. THE SHEAR PIN HOLES IN THE ANGLE SHALL BE DRILLED FOR A TIGHT FIT OF THE SHEAR PINS.
4. FRAME AND HINGE ANGLES SHALL HAVE THE OUTSTANDING LEGS OUT FOR OUTLETS.
5. ALL ANCHOR BOLTS SHALL BE 5/8"Ø ANCHOR BOLTS EMBEDDED 4" (MIN.) INTO EPOXY GROUT.
6. ALL SHEAR PINS ARE TO BE PEENED BOTH ENDS AFTER INSTALLATION.
7. SHEAR PIN MATERIAL SHALL BE COMMERCIAL PURE ALUMINUM WIRE.
8. SEE BARRIER SCHEDULE, DET. 2562-2 FOR VARIABLE DIMENSIONS.
9. COVER ALL MOVABLE CONTACT SURFACE WITH A COAT OF WATERPROOF GREASE PRIOR TO INSTALLATION.
10. ALL BARRIER BARS TO BE 1/2" PLAIN.

HINGE PIN
BOLT STOCK, THREAD BOTH ENDS SO NUT & LOCK WASHER ARE FLUSH WITH LOWER ∟, UPSET OR DAMAGE EXPOSED THREADS. COAT PIN WITH WATERPROOF GREASE BEFORE INSTALLATION.

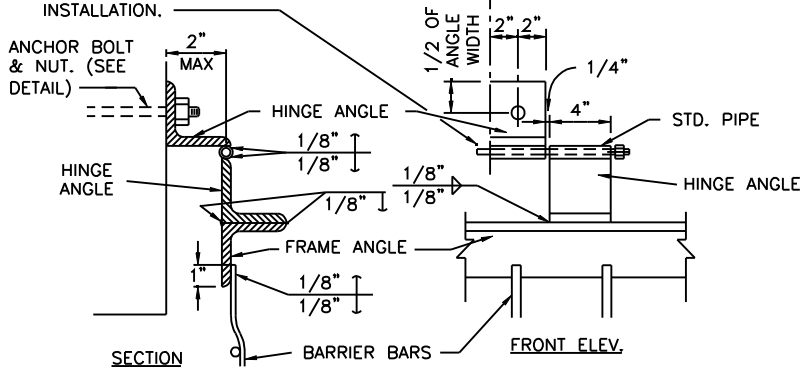

HINGE INSTALLATION DETAIL

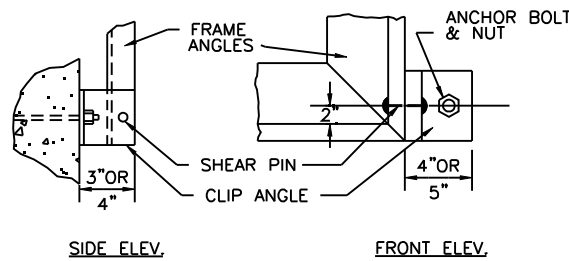

CLIP ANGLE & SHEAR PIN DETAIL

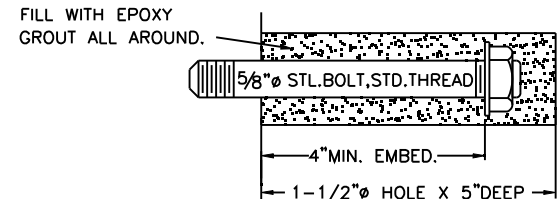

ANCHOR BOLT DETAIL

DETAIL NO. **2562-1** **City of Scottsdale Standard Details**

APPROVED BY: **Scottsdale Standards & Specifications Committee**

STORM SEWER OUTFALL ACCESS BARRIER **2562-1**

DETAIL NO. **2562-1**

REVISED: 3/28/02

SIZE OF OUTFALL CONDUIT	FRAME ANGLES	SHEAR PIN CLIP ANGLES	SHEAR PINS	HINGE PINS	HINGE ANGLES	HINGE STD. PIPE	* NO. OF EQUAL BARRIER BAR SPACES (HORIZ.)	NO. OF EQUAL BARRIER BAR SPACES (VERT.)	H (OUT TO OUT FRAME ANGLES)	* W (OUT TO OUT FRAME ANGLES)	A	B
30"	2X2X1/4	4X4X1/4	1-1/8 \emptyset	1/2" \emptyset	2X2X1/4	3/4"	3	5	34"	20"	SINGLE HINGE CENTERED	
36"	2X2X1/4	4X4X1/4	1-1/8 \emptyset	3/4" \emptyset	2-1/2X 2-1/2X1/4	1"	4	6	40"	26"	SINGLE HINGE CENTERED	
42"	2X2X1/4	4X4X1/4	2-1/8 \emptyset	1/2" \emptyset	2X2X1/4	3/4"	5	6	42"	32"	0	0
48"	3X3X7/16	5X3X1/4	2-1/8 \emptyset	3/4" \emptyset	2-1/2X 2-1/2X1/4	1"	5	7	47"	38"	3"	1"
54"	3X3X7/16	5X3X1/4	2-1/8 \emptyset	3/4" \emptyset	2-1/2X 2-1/2X1/4	1"	6	8	54"	44"	5"	3"
60"	3X3X7/16	5X3X1/4	2-1/8 \emptyset	3/4" \emptyset	2-1/2X 2-1/2X1/4	1"	7	9	60"	50"	9"	4"
66"	3X3X7/16	5X3X1/4	2-1/8 \emptyset	3/4" \emptyset	2-1/2X 2-1/2X1/4	1"	8	10	66"	56"	11"	6"
72"	4X4X5/8	5X3X1/4	2-3/16 \emptyset	1" \emptyset	3X3X3/8	1-1/4"	9	11	73"	62"	15"	7"
78"	4X4X5/8	5X3X1/4	2-3/16 \emptyset	1" \emptyset	3X3X3/8	1-1/4"	10	11	79"	68"	17"	9"
84"	4X4X5/8	5X3X1/4	2-3/16 \emptyset	1" \emptyset	3X3X3/8	1-1/4"	11	13	86"	74"	21"	10"
90"	4X4X5/8	5X3X1/4	2-3/16 \emptyset	1" \emptyset	3X3X3/8	1-1/4"	12	13	92"	80"	23"	12"
96"	4X4X5/8	5X3X1/4	2-3/16 \emptyset	1" \emptyset	3X3X3/8	1-1/4"	12	14	98"	86"	29"	12"

*NOTE: Adjust these values for skewed conduits. Provide 5" maximum opening at each side and between bars.

REVISED 05/05/08

MINIMUM TREE SIZE REQUIREMENTS

Name	Size	Height	Width	Caliper	Name	Size	Height	Width	Caliper	Name	Size	Height	Width	Caliper	Name	Size	Height	Width	Caliper																
ACACIA					IRONWOOD					MESQUITE (Cont.)					OTHER TREES																				
BERLANDER	15	4	2	0.5	DESERT IRONWOOD	15	3	2	0.5	VELVET ARIZONA (M)	15	5.5	3	0.5	ALEPPO	15	6	3	0.75	COOLIBAH	15	7	3	0.75											
GUAJILLO (M)	24	5	4	1	(OLNEYA TESOTA)	24	6	3	1.25	(PROSOPIS VELUNTINA)	24	7	4	1	(PINUS HALEPENSIS)	24	9	4	2	(EUCALYPTUS - MICROTHECA)	24	10	4	1.5											
(ACACIA BERLANDIERI)	30	7	5	1.5			30	8	6	2		30	9	6	1.5		30	11	6	3		30	12	5	2										
	36	9	6	2			36	10	8	2.5		36	10	8	2		36	14	7	3.5		36	15	6	2.5										
MULGA	15	5	2	0.75			42	11	9	3		42	12	10	2.5		42	16	9	4		42	16	9	4										
(ACACIA ANEURA)	24	7	4	1.5			48	12	10	3.5		48	14	12	3		48	18	10	4.5		48	18	10	4.5										
	30	9	6	2	DESERT IRONWOOD (M)	15	3	2	0.5	PALOVERDE					ARIZONA SYCAMORE	15	7	2	1		15	4	2	0.75		15	4	2	0.75						
	36	10	8	2.5	(OLNEYA TESOTA)	24	6	3	1.25	BLUE PALO VERDE	15	6	2	0.75	(PLATANUS WRIGHTII)	24	9	4	1.5		24	6.5	3	1.5		24	6.5	3	1.5						
SHOESTRING	15	7	2.5	0.75			30	8	6	2	(PARKINSONIA FLORIDUM)	24	7.5	4	1.5		30	13	6	2.5		30	9	4.5	2.5		30	9	4.5	2.5					
(ACACIA STENOPHYLLA)	24	9	4	1.5			36	10	8	2.5		30	9	7	2		36	16	8	3.5		36	12	6	3.5		36	12	6	3.5					
	30	11	5	2			42	11	9	3		36	10	8	2.5		42	14	9	4		42	14	9	4		42	14	9	4					
	36	13	6	2.5			48	12	10	3.5		42	12	9	3		48	16	11	4.5		48	16	11	4.5		48	16	11	4.5					
	42	15	7	3	MESQUITE							48	14	10	3.5		36	16	8	3.5		36	16	8	3.5		36	16	8	3.5					
	48	17	8	4	CHILEAN MESQUITE	15	6	2	0.75	BLUE PALO VERDE (M)	15	5	3	0.5	(PLATANUS WRIGHTII)	15	6	3	0.5		15	6	3	0.5		15	6	3	0.5		15	6	3	0.5	
SHOESTRING (M)	15	7	2.5	0.5	(PROSOPIS CHILENSIS)	24	8	4	1.5	(PARKINSONIA FLORIDUM)	24	7	4	1	AUSTRALIAN WILLOW	15	5	3	0.75		15	6	3	0.5		15	6	3	0.5		15	6	3	0.5	
(ACACIA STENOPHYLLA)	24	9	4	1			30	9	6	2		30	8	6	1.5	WILGA	24	8	4	1.25		24	8	4	1.25		24	8	4	1.25		24	8	4	1.25
	36	13	6	2			36	10	8	2.5		36	10	8	2	(GEIJERA PARVIFLORA)	30	10	5	2		30	10	5	2		30	10	5	2		30	10	5	2
SWEET	15	6	2.5	0.75			42	12	10	3		42	12	9	2.5		36	12	5.5	2.5		36	12	5.5	2.5		36	12	5.5	2.5		36	12	5.5	2.5
(ACACIA SMALLII)	24	8	4	1.5			48	14	12	3.5		48	14	11	3	CHASTE TREE	15	5	3	0.75		15	5	3	0.75		15	5	3	0.75		15	5	3	0.75
	30	9	6	2	CHILEAN MESQUITE (M)	15	5	3	0.5	LITTLE LEAF	15	4	2	0.5	(VITEX ANGUS-CASTUS)	24	6	4	1.25		24	6	4	1.25		24	6	4	1.25		24	6	4	1.25	
	36	10	8	2.5	(PROSOPIS CHILENSIS)	24	8	5	1	FOOTHILLS	24	6	3	1		30	7	5	2		30	7	5	2		30	7	5	2		30	7	5	2	
	42	12	10	3			30	9	7	1.5	(PARKINSONIA MICROPHYLLUM)	30	7	5	1.5		36	8	6	2.5		36	8	6	2.5		36	8	6	2.5		36	8	6	2.5
	48	14	12	3.5			36	10	9	2		36	8	6	2	CHINESE EVERGREEN	15	7	2	0.75		15	7	2	0.75		15	7	2	0.75		15	7	2	0.75
SWEET (M)	15	5	3	0.5			42	12	11	2.5	LITTLE LEAF	15	4	3	0.5	ELM	24	8	3	1.25		24	8	3	1.25		24	8	3	1.25		24	8	3	1.25
(ACACIA SMALLII)	24	8	5	1			48	14	13	3	FOOTHILLS (M)	24	5	4	1	(ULMUS PARVIFOLIA)	30	12	6	2		30	12	6	2		30	12	6	2		30	12	6	2
	30	9	7	1.5	HONEY MESQUITE (M)	15	6	2	0.75	(PARKINSONIA MICROPHYLLUM)	30	6	5	1.5		36	14	8	2.5		36	14	8	2.5		36	14	8	2.5		36	14	8	2.5	
	36	10	9	2	(PROSOPIS - GLANDULOSA)	24	8	4	1.5		36	8	7	2		42	16	9	3.5		42	16	9	3.5		42	16	9	3.5		42	16	9	3.5	
	42	12	10	2.5			30	9	6	2	SONORAN	15	6	2	0.75	CHINESE PISTACHE	15	7	2	0.75		15	7	2	0.75		15	7	2	0.75		15	7	2	0.75
	48	14	12	3			36	10	8	2.5	(PARKINSONIA PRAECOX)	24	7	4	1.5	(PISTACIA CHINENSIS)	24	9	4	1.5		24	9	4	1.5		24	9	4	1.5		24	9	4	1.5
WILLOW	15	6	2	0.75			42	12	10	3		30	8	6	2		30	10	5	2.5		30	10	5	2.5		30	10	5	2.5		30	10	5	2.5
AUSTRALIAN WILLOW	24	8	4	1.5			48	14	12	3.5		36	10	8	2.5		36	12	6	3.5		36	12	6	3.5		36	12	6	3.5		36	12	6	3.5
(ACACIA SALICINA)	30	10	5	2	SCREW BEAN (M)	15	5.5	3	0.5		42	11	10	3		48	18	10	3.75		48	18	10	3.75		48	18	10	3.75		48	18	10	3.75	
	36	14	6	2.5	(PROSOPIS - PUBESCENS)	24	8	4	1		48	12	12	3.5		15	5	3	1		15	5	3	1		15	5	3	1		15	5	3	1	
							30	9	6	1.5	SONORAN (M)	15	5	2	0.5	CHIR PINE/ INDIAN	24	8	4	2		24	8	4	2		24	8	4	2		24	8	4	2
							36	10	8	2	(PARKINSONIA PRAECOX)	24	7	4	1	LONG LEAF	30	11	6	2.5		30	11	6	2.5		30	11	6	2.5		30	11	6	2.5
							42	12	10	3		30	8	6	1.5	(PINUS ROXBURGHII)	36	15	6.5	3.5		36	15	6.5	3.5		36	15	6.5	3.5		36	15	6.5	3.5
							48	14	12	3.5		36	10	8	2		42	17	8	4.5		42	17	8	4.5		42	17	8	4.5		42	17	8	4.5
											42	11	10	2.5		48	20	9	5		48	20	9	5		48	20	9	5		48	20	9	5	
											48	12	12	3																					

See General Notes
On Page 2

Page 1 of 2

REVISED 05/05/08

MINIMUM TREE SIZE REQUIREMENTS

Name	Size	Height	Width	Caliper	Name	Size	Height	Width	Caliper	Name	Size	Height	Width	Caliper	Name	Size	Height	Width	Caliper					
FICUS (FICUS NITIDA)	15	8	2	0.75	MEXICAN PALO VERDE JERUSALEM (PARKINSONIA ACULEATA)	15	7	3	1	RED GUM (EUCALYPTUS- CAMALDULENSIS)	15	8	3	1	SILK TREE MIMOSA (M) (ALBIZIA JULIBRISSIA)	15	5	3.5	0.5	SILK TREE MIMOSA (ALBIZIA JULIBRISSIN)	15	6	3	0.75
	24	9	4	1.5		24	9	6	1.5		24	10	4	1.75		24	6.5	5	0.75		24	8	4	1.5
	30	10	5	2		30	11	9	2.5							30	6	6	1		30	10	6	2
	36	12	6	3		36	12	10	3							36	10	8	2.5		36	12	8	3
FICUS (M) (FICUS NITIDA M)	15	5.5	3	0.5	MODESTO ASH (FRAXINUS V MODESTO)	15	8	2	1	RED IRON BARK (EUCALYPTUS - SIDEROXYLON)	24	10	4	1.5	SILVER DOLLAR GUM (EUCALYPTUS- POLYANTHEMOS)	15	7	3	0.75	TEXAS EBONY (M) (PITHECELLUBIUM- FLEXICAULE)	15	4	2	0.5
	24	8	4	1		24	10	4	1.5		24	10	4	1.5		24	10	4	1.5		24	6	4	1
	30	10	6	2		30	12	6	2		15	7	2	0.75							30	7	6	1.5
	36	12	8	2.5		36	14	7	2.5							15	7	3	0.75					
FLOODED GUM (EUCALYPTUS RUDIS)	15	8	3	1	OLIVE TREE (OLEA EUROPAEA)	42	16	8	3	TEXAS ASH (FRAXINUS V FANTEX)	30	12	5	2	SISSOO (DALBERGIA SISSOO)	15	7	3	0.75	YELLOW OLEANDER (THEVETIA PERUVIANA)	15	6	2	0.5
	24	10	4	1.5		48	17	10	3.5		42	15	9	3.5		30	12	7	2.5		24	10	10	2.5
FLOWERING CHERRY (PRUNUS VARIETIES)	15	6	2.5	0.75	NARROW LEAF GIMLET SWAMP MALLET (EUCALYPTUS - SPATHULATA)	15	6	2.5	0.75	SHAMEL EVERGREEN (FRAXINUS UHDEI)	48	16	10	4	SOUTHERN LIVE OAK HERITAGE (QUERCUS VIRGINIANA)	15	6	2	0.75		24	8	4	1.25
	24	9	4	1.25		24	8	3	1		15	8	2	1		24	9	4	1.25		30	11	6.5	2
	30	11	8	2							30	12	5	2.5		36	13	8	2.75		42	15	10	3.5
	36	13	10	2.5							36	14	8	3		48	17	12	4.5					
HONEY LOCUST (GLEDITSIA TRIACANTHOS INERMIS)	15	8	2	0.75	OLIVE TREE (OLEA EUROPAEA)	15	5	3	0.5	SILK OAK (GREVILLEA ROBUSTA)	42	15	9	3.5	TEXAS EBONY (PITHECELLOBIUM- FLEXICAULE)	15	5	2	0.75		24	6	3	1.5
	24	9	4	1.5		24	8	5.5	1.5		24	10	4	1.5		36	13	8	2.75		42	10	6	3
	30	10	6	2		30	11	9	2		36	14	8	3		48	17	12	4.5		48	11	7	3.5
	36	12	8	2.5		36	12	10	3		48	16	10	4										
JACARANDA (JACARANDA ACUTIFOLIA)	15	8	2	0.75	ORCHID TREE (BAUHINIA)	15	8	2	0.75															
	24	9	4	1.5		24	9	4	1.25															
	30	12	5	2.5		30	11	6	2															
	36	14	8	3		36	13	7	2.5															
JACARANDA (M) (JACARANDA- ACUTIFOLIA)	15	5.5	3	0.5	RAYWOOD ASH CLARET ASH (FRAXINUS O RAYWOODII)	15	8	4	1															
	24	8	5	0.75		24	10	3	1.5															
	30	10	6	1.5		30	12	5	2															
	36	12	7	2		36	14	8	2.5															
MESCAL BEAN TEXAS MOUNTAIN LAUREL (SOPHORA - SECUNDIFLORA)	15	3	1	0.75	RED CAP GUM (EUCALYPTUS- ERYTHROCORYES)	15	6.5	2.4	0.75															
	24	4	2	1		24	8	4	1.25															
MESCAL BEAN TEXAS MOUNTAIN LAUREL (M) (SOPHORA - SECUNDIFLORA)	15	3	2	0.75																				
	24	4	3	1																				
	30	5	4	1.5																				
	36	6	5	2																				

GENERAL NOTES:

1. All trees shall be guaranteed for one year from the date of acceptance
2. "M" designates a multitrunk tree. A multitrunk tree is a tree with more than one main trunk.
3. Caliper is measured at 12" above the ground for trees with caliper greater than 4". For multitrunk trees, and trees with caliper of less than 4", the caliper is measured 6" above the ground.
4. Size is listed as the box size in inches except for those trees in 15 gallon containers.

REVISED 3/1/12

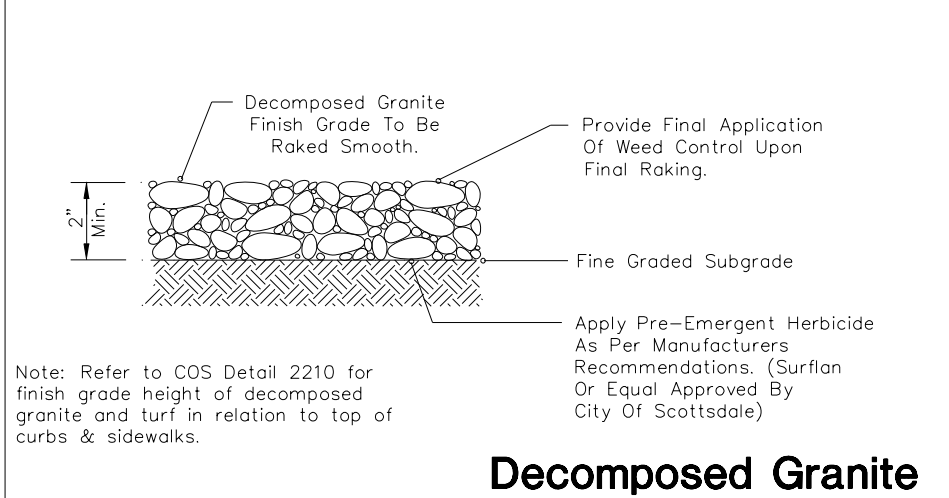
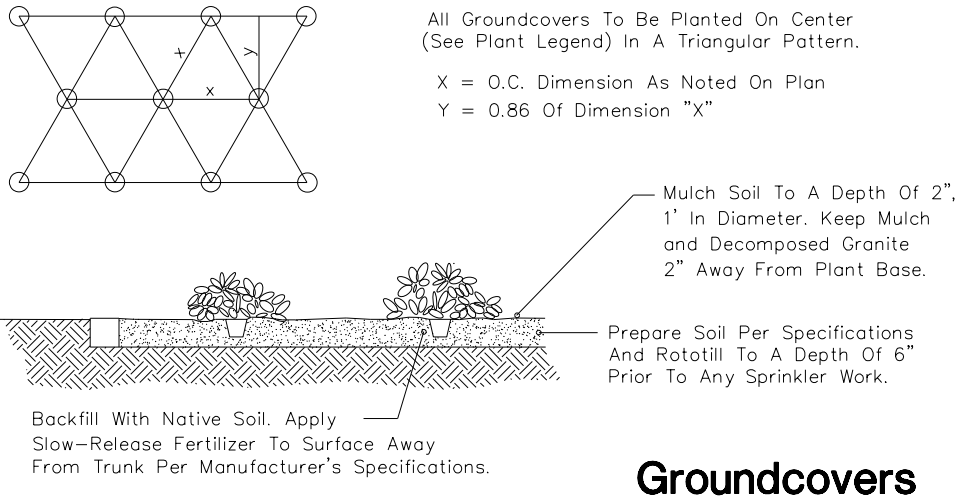
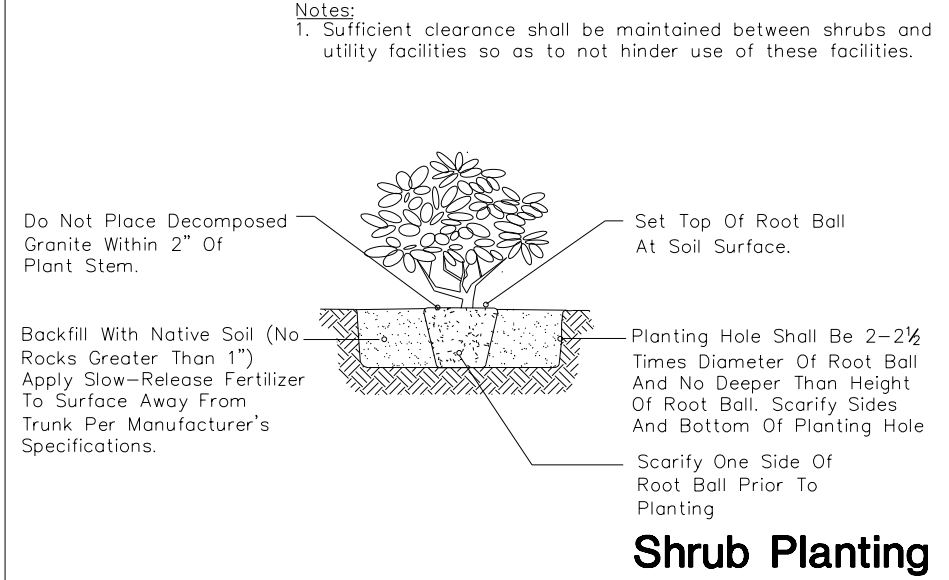
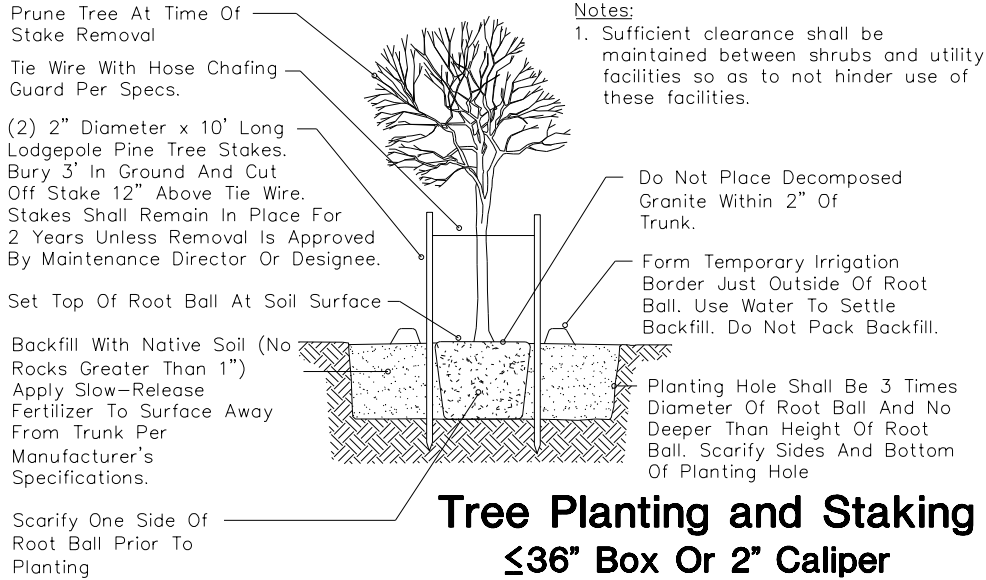

DETAIL NO.
2620-1

City of Scottsdale
Standard Details

APPROVED BY:
Scottsdale Standards & Specifications Committee

LANDSCAPE DETAILS

DETAIL NO.
2620-1

REVISED 3/1/12

① Do Not Place Decomposed Granite Within 2" Of Planting Base.

Garden Hose Reinforced With Wire (Metal).

Use Golf Sand Or 1/4" Minus Decomposed Granite To Backfill Planting Hole. Backfill 1/2 Of Pit, Then Compact.

Root Prune All Shredded Or Damaged Roots And Dust Entire Root Structure With Wettable Sulphur (1.5 ML Min.) And Streptomycin Spray At Planting Site. Root Ball Minimum Size Shall Be 24" With A Minimum Root Length Of 6" On All Sides.

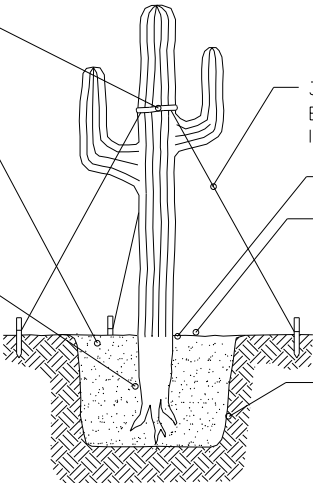

3 Tree Braces, Spaced Equally. Braces To Remain In Place For One Year Min.

①

6 - 1 Gallon Emitters In 'Hula Hoop' Distribution, Run Once A Month 24 To 48 Hours For One Year.

Planting Hole Width Shall Be 3 Times Diameter Of Roots And No Deeper Than The Extension Of The Roots.

Saguaro Planting Type A

NOTES:

1. Optimum transplanting season is October thru November.
2. Maintain original plant orientation. The original "North" orientation shall be marked on a rib at a height of 5' above ground level.
3. Water thoroughly at the time of transplanting to remove air pockets and assure proper compaction. Backfill shall be free of injurious rocks and debris.
4. Do not water for 3 weeks after planting.
5. Plant in areas safe from present and future construction activities.
6. Transplant to original depth of bury.

NOTE: Water weekly through the summer.

Plant At Depth Which Plant Was Grown.

①

Planting Mix To Be 1/3 Golf Sand And 2/3 Specified Soil. Pack The Backfill Mix, Do Not Use Water To Settle Backfill Mix.

Planting Hole Width Shall Be 3 Times Diameter Of Roots And No Deeper Than The Extension Of The Roots.

Use 6" to 8" Rocks To Anchor Roots.

Root Prune All Shredded Or Damaged Roots And Dust Entire Root Structure With Wettable Sulphur (1.5 ML min.) At Planting Site.

Avg. of 75f Taller Canes

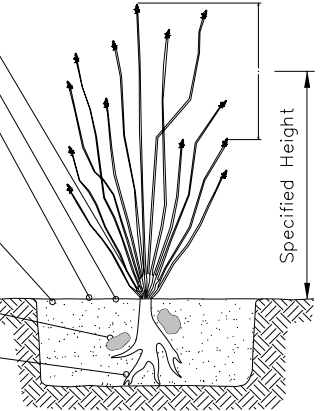

Specified Height

Ocotillo Planting

(3) 2"x 6" Braces, Spaced Equally And Nailed To Wooden Stakes In The Ground. Braces To Remain In Place For One Year Min.

Use Golf Sand Or 1/4" Minus Decomposed Granite To Backfill Planting Hole. Backfill 1/2 Of Pit, Then Compact.

Root Prune All Shredded Or Damaged Roots And Dust Entire Root Structure With Wettable Sulphur (1.5 ML Min.) And Streptomycin Spray At Planting Site. Root Ball Minimum Size Shall Be 24" With A Minimum Root Length Of 6" On All Sides.

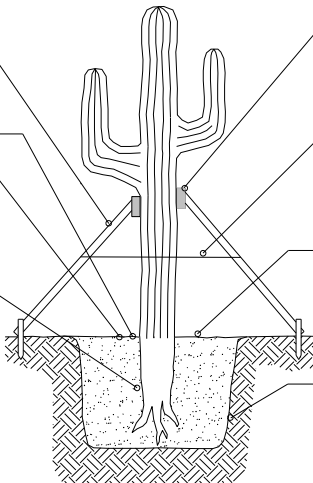

4"x 8" - Dense Foam And Carpet Padded, 8' Above Natural Grade And Nailed To Brace.

Steel Band Fastened With 2 Large Staples Per Brace.

6 - 1 Gallon Emitters In 'Hula Hoop' Distribution, Run Once A Month 24 To 48 Hours For One Year.

Planting Hole Width Shall Be 3 Times Diameter Of Roots And No Deeper Than The Extension Of The Roots.

Saguaro Planting Type B

NOTES:

1. Optimum transplanting season is October thru November.
2. Maintain original plant orientation. The original "North" orientation shall be marked on a rib at a height of 5' above ground level.
3. Water thoroughly at the time of transplanting to remove air pockets and assure proper compaction. Backfill shall be free of injurious rocks and debris.
4. Do not water for 3 weeks after planting.
5. Plant in areas safe from present and future construction activities.
6. Transplant to original depth of bury.

NOTE: Water weekly through the summer. Maintain original growing orientation.

Plant At Depth Which Plant Was Grown.

Planting Mix To Be 1/3 Golf Sand And 2/3 Specified Soil. Pack The Backfill Mix, Do Not Use Water To Settle Backfill Mix.

Planting Hole Width Shall Be 3 Times Diameter Of Roots And No Deeper Than The Extension Of The Roots.

Use 6" to 8" Rocks To Anchor Roots.

Root Prune All Shredded Or Damaged Roots And Dust Entire Root Structure With Wettable Sulphur (1.5 ML min.) At Planting Site.

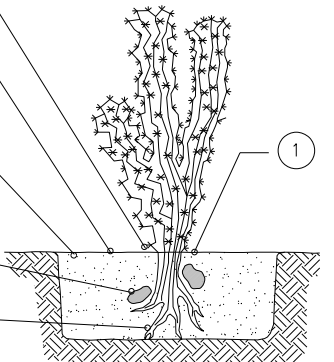

①

Cactus Planting

DETAIL NO.
2620-2

City of Scottsdale
Standard Details

APPROVED BY:
Scottsdale Standards & Specifications Committee

LANDSCAPE DETAILS

DETAIL NO.
2620-2

REVISED 3/1/12

Staking Required For Trees In 36" Box Or Less Or With A Caliper Of Less Than 2". (2) 2" Diameter x 10' Long Lodgepole Pine Tree Stakes. Bury 3' In Ground And Cut Off Stake 12" Above Tie Wire. Stakes Shall Remain In Place For 2 Years Unless Removal Is Approved By Maintenance Director Or Designee.

Do Not Place Decomposed Granite Within 2" Of Trunk.

Backfill With Native Soil. (No Rocks Greater Than 3") Backfill 3/4 The depth Of Rootball Before Removing Box Side Panels. Compact Backfill As Needed To Prevent Breaking Rootball.

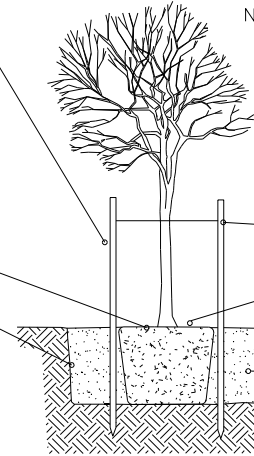

- Notes: 1. Sufficient clearance shall be maintained between trees and utility facilities so as to not hinder use of these facilities.
2. Plant pit basins within sloped planting areas shall be constructed with a max. 2:1 slope. Provide smooth transition to surrounding finish grade.

Tie Wire With Hose Chafing Guard Per Specs. As Required.

Set Top Of Root Ball At Soil Surface.

Planting Hole Shall Be 3 Times Diameter Of Root Ball And No Deeper Than Height Of Rootball. Scarify Sides And Bottom Of Planting Hole

Salvaged Tree Planting

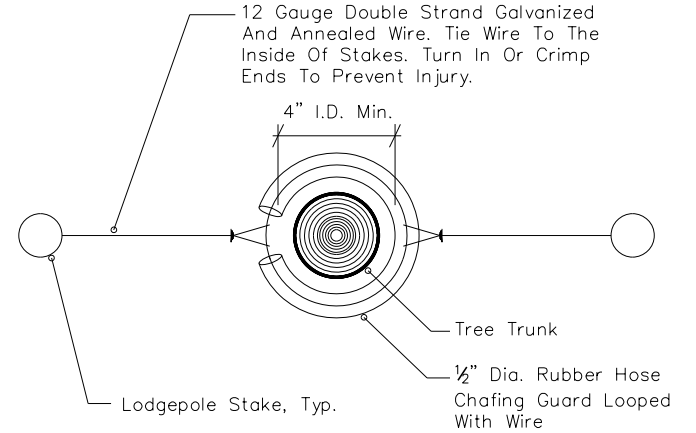

Tree Staking - Plan View

Thin Top 6-8 Fronds, Tie With Natural Fiber Twine. (Remove Ties Prior To Buckling 60-90 Days).

Plant At Depth Which Plant Was Grown. Adjusting Root Ball Depth To Align Finished Height Will Not Be Allowed.

Do Not Place Decomposed Granite Within 2" Of Trunk.

100% Golf Sand Backfill. Settle Backfill With Water, Do Not Pack Backfill.

Planting Hole Width Shall Be 3 Times Diameter Of Roots And No Deeper Than The Extension Of The Roots.

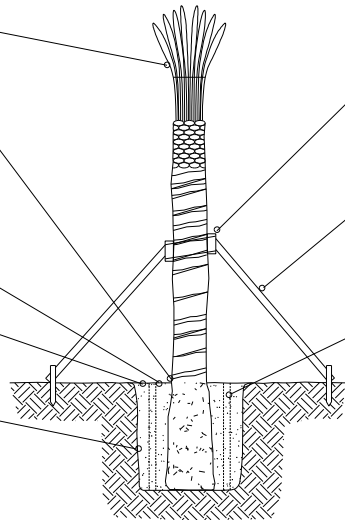

Palm Planting and Bracing Detail

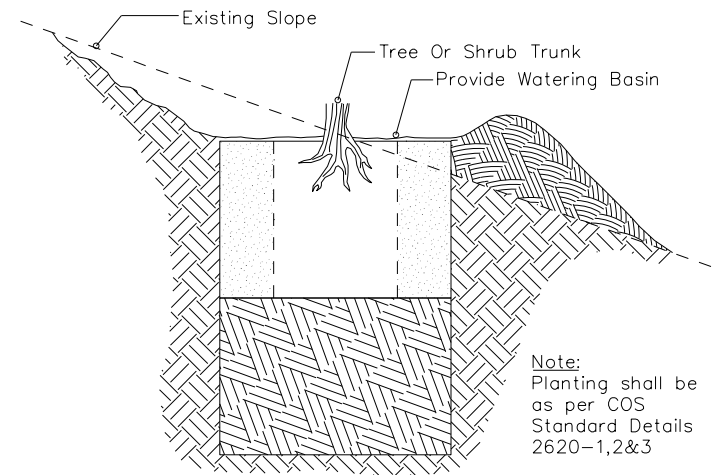

Tree & Shrub On Slope Planting

DETAIL NO.
2620-3

**City of Scottsdale
Standard Details**

APPROVED BY:
**Scottsdale Standards &
Specifications Committee**

LANDSCAPE DETAILS

DETAIL NO.
2620-3

NEW 4/16/09

Note:
No Materials Shall Be
Stored Within The Tree
Protection Areas

Place Signs:

KEEP OUT
TREE PROTECTION
AREA

Every 50' Attached To Fencing

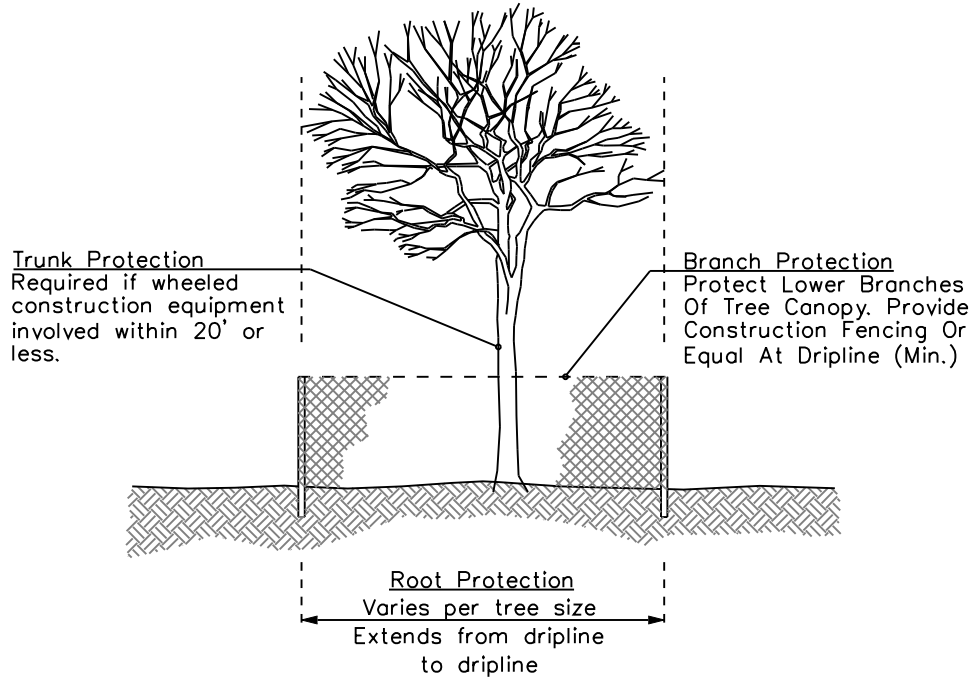

Tree Protection

NOTES:

1. All trees to be protected within the construction area shall be identified with white survey tape wrapped around the trunk. Grouping of more than one tree within the tree protection zone may occur.
2. To prevent tree root smothering, soil stockpiles, supplies, equipment or any other material shall not be placed or stored within a tree drip line or within 25 feet of a tree trunk, whichever is greater.
3. Trenches shall be hand dug within the drip line in areas where roots two inches in diameter and greater are present, or when in close proximity to low branching trees. Whenever possible, roots two inches or greater in diameter shall be tunneled or bored under and shall be covered to prevent dehydration.
4. Tree roots shall not be cut unless cutting is unavoidable. When root cutting is unavoidable, a clean sharp cut with an approved pruning saw shall be made to avoid shredding or smashing. Root cuts should be made back to a lateral root. Whenever possible, tree roots should be cut between late fall and bud opening, when root energy supplies are high and conditions are least favorable for disease-causing agents. Exposed roots shall be covered immediately to prevent dehydration. Roots shall be covered with soil or burlap and kept moist. Backfill material around damaged roots shall be a light mulch/sand mixture to promote root recovery.
5. Watering of protected trees in which roots were cut shall be provided by the contractor. Watering schedule to be established by City arborist.
6. Horizontal boring rather than trenching should be used for utility placement within drip line of tree whenever possible.
7. Fencing material shall encircle any tree whose outer drip line edge is within 25 feet of any construction activities.
8. Fencing material shall be orange construction fence a minimum of 4 feet in height.
9. Fencing material shall be set at the drip line or 25 feet from tree trunk, whichever is greater, and maintained in an upright position throughout the duration of construction activities.
10. Any grade changes or retaining wall/tree well installation within the drip line shall be approved by City arborist.

NEW 6/12/12

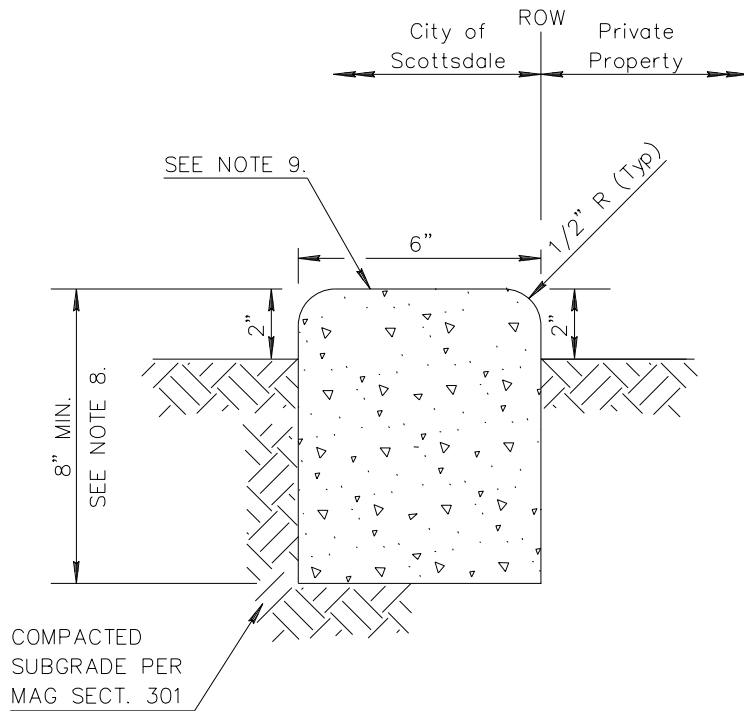

HEADER CURB

NOTES:

1. ALL VERTICAL SURFACES TO BE FORMED.
2. VERTICAL SURFACES DOWN FROM 2" BELOW UNDISTURBED SOIL MAY BE PLACED AGAINST NEAT CUT IF APPROVED BY THE ENGINEER AND CONCRETE WILL NOT EXTEND MORE THAN 1" BEYOND THEORETICAL FACE.
3. ALL EXPOSED SURFACES TO BE STRIPPED GREEN AND TROWEL FINISHED.
4. CONCRETE CURBS CONFORM TO SECT. 340.
5. MAXIMUM SPACING OF CONTRACTION JOINTS IS 10' MAXIMUM.
6. EXPANSION JOINTS PER SECT. 340, 50' MAXIMUM SPACING.
7. CONCRETE TO BE CLASS 'B' PER SECT. 725.
8. HEADER SHALL HAVE AN 18" DEPTH IF HEADER IS SUBJECT TO SCOUR WHEN CONTAINING RIP-RAP AREAS.
9. TOP OF HEADER TO BE FLUSH WITH TOP OF ANY ADJACENT CONCRETE SURFACES.
10. ENSURE A SMOOTH AND EVEN TRANSITION WHERE CONCRETE HEADER TERMINATES AT SIDEWALK OR WALL.
11. COLOR TO MATCH ADJACENT SIDEWALKS OR STANDARD CONCRETE COLOR IF NOT ADJACENT TO OTHER PAVING.

DETAIL NO.
2622

City of Scottsdale
Standard Details

APPROVED BY:
Scottsdale Standards & Specifications Committee

LANDSCAPE CONCRETE HEADER

DETAIL NO.
2622

REVISED 6/12/12

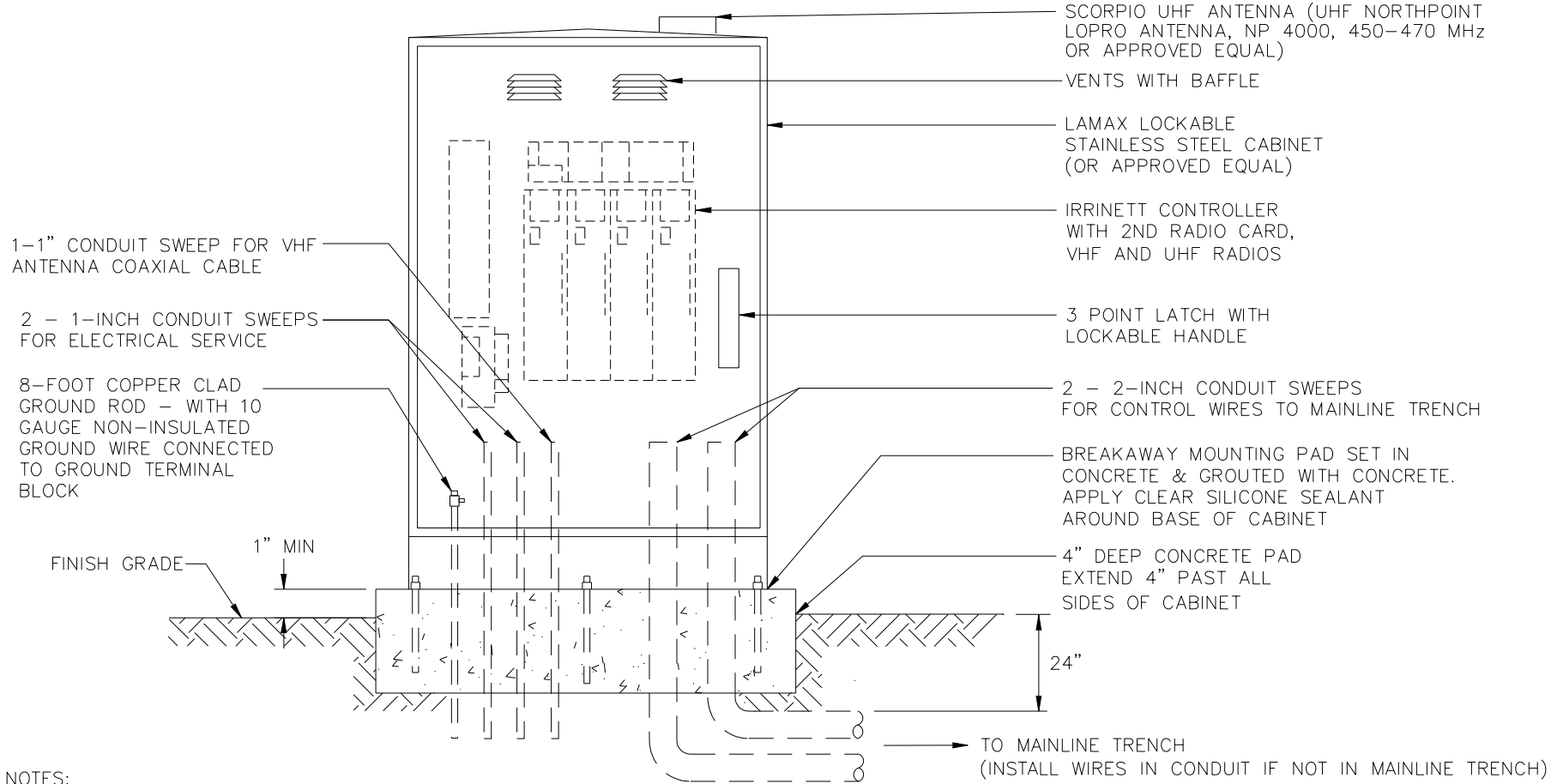

NOTES:

1. POWER SOURCE FOR CONTROLLER TO BE HARD WIRED FROM CIRCUIT BREAKER MOUNTED INSIDE CABINET TO CONTROLLER.
2. LOCATION OF POWER SOURCE TO BE NOTED ON CIRCUIT BREAKER PANEL.
3. CONTROLLER TO BE LOCATED IN AREA WITH POSITIVE DRAINAGE.
4. INSTALL ONLY ONE CONTROL VALVE WIRE PER CONTROLLER OUTPUT.
5. VHF AND UHF RADIOS TO BE TUNED TO C.O.S. FREQUENCIES. CONTACT IRRIGATION DEPARTMENT FOR INFORMATION (480-312-2189)
6. ANTENNA TYPE, MAST & MOUNTING INSTALLATION TO BE APPROVED BY CITY OF SCOTTSDALE IRRIGATION DEPARTMENT.
7. POWER SOURCE TO BE PROVIDED BY CONTRACTOR FOLLOWING NEC REQUIREMENTS. INSTALLATION TO BE INSPECTED AND APPROVED BY COS INSPECTOR. INSTALL METAL ADDRESS LABELS TO OUTSIDE DOOR OF IRRIGATION CONTROLLER CABINETS FOR ALL CONTROLLERS RECEIVING NON-METERED POWER SUPPLY.

DETAIL NO.
2631

City of Scottsdale
Standard Details

APPROVED BY:
Scottsdale Standards & Specifications Committee

IRRINET PEDESTAL MOUNTED CONTROLLER

DETAIL NO.
2631

REVISED 6/13/12

SCORPIO UHF ANTENNA (UHF NORTHPOINT LOPRO ANTENNA, NP 4000, 450-470 MHz OR APPROVED EQUAL)

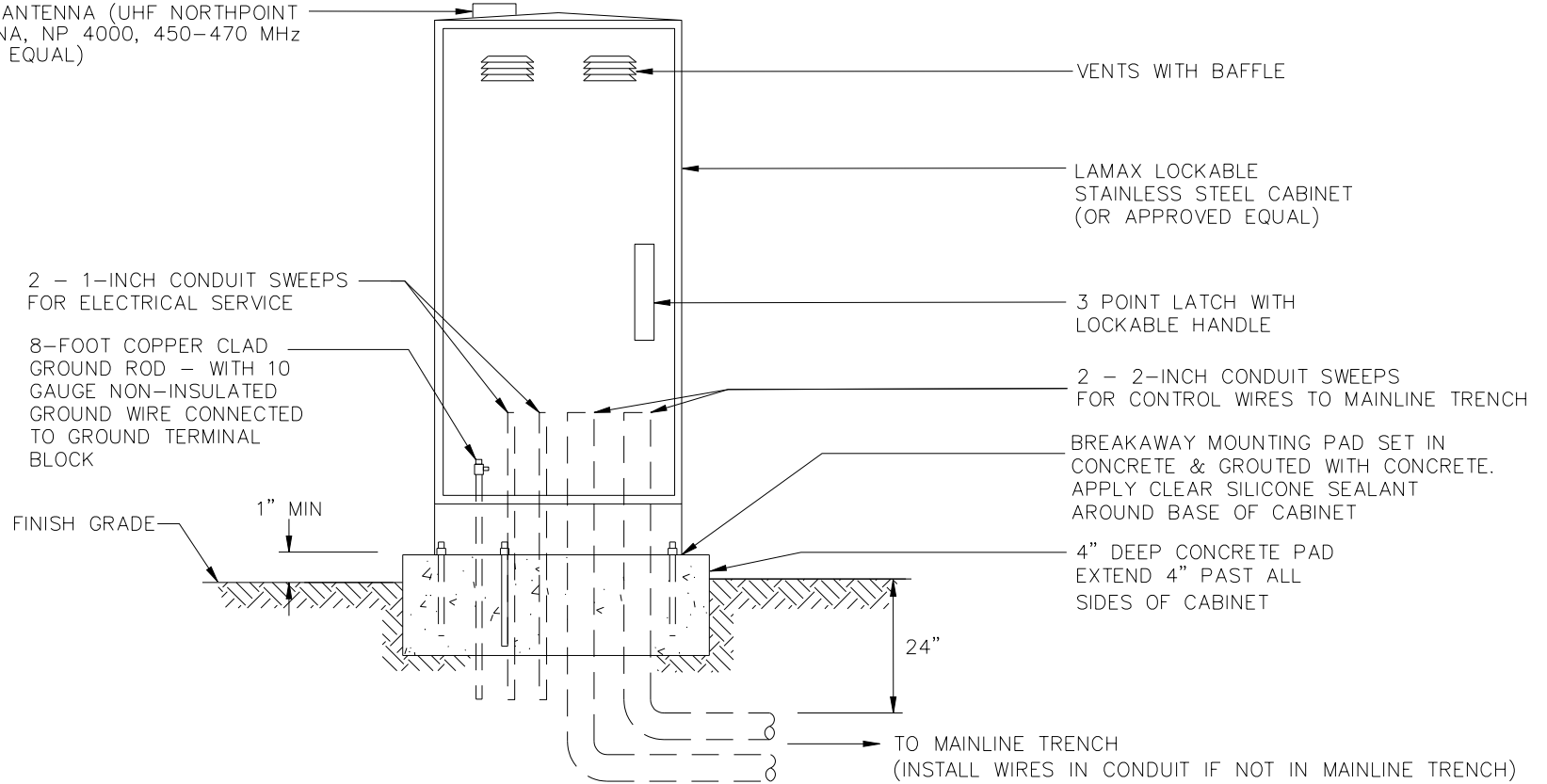

NOTES:

1. POWER SOURCE FOR CONTROLLER TO BE HARD WIRED FROM CIRCUIT BREAKER MOUNTED INSIDE CABINET TO CONTROLLER.
2. LOCATION OF POWER SOURCE TO BE NOTED ON CIRCUIT BREAKER PANEL.
3. REMOTE CONTROL VALVES FOR D.C. SCORPIO APPLICATIONS MUST HAVE D.C. LATCHING SOLENOIDS AND APPROVED SOLAR PANEL FOR POWER SOURCE.
4. MIDLAND NARROW BAND RADIO # 2845 G TO BE INSTALLED WITH SCORPIO CONTROLLER.
5. CONTROLLER TO BE LOCATED IN AREA WITH POSITIVE DRAINAGE.
6. INSTALL ONLY ONE CONTROL VALVE WIRE PER CONTROLLER OUTPUT.
7. UHF RADIO TO BE TUNED TO C.O.S. FREQUENCIES. CONTACT IRRIGATION DEPARTMENT FOR INFORMATION (480-312-2189)
8. POWER SOURCE TO BE PROVIDED BY CONTRACTOR FOLLOWING NEC REQUIREMENTS. INSTALLATION TO BE INSPECTED AND APPROVED BY COS INSPECTOR. INSTALL METAL ADDRESS LABELS TO OUTSIDE DOOR OF IRRIGATION CONTROLLER CABINETS FOR ALL CONTROLLERS RECEIVING NON-METERED POWER SUPPLY.

DETAIL NO.
2632

City of Scottsdale
Standard Details

APPROVED BY:
Scottsdale Standards & Specifications Committee

SCORPIO PEDESTAL MOUNTED CONTROLLER

DETAIL NO.
2632

REVISED 3/7/12

SCORPIO UHF ANTENNA (UHF NORTHPOINT LOPRO ANTENNA, NP 4000, 450-470 MHz OR APPROVED EQUAL)

LAMAX LOCKABLE STAINLESS STEEL CABINET (OR APPROVED EQUAL)

1/2-INCH E.M.T. CONDUIT FOR 110V POWER SUPPLY

8-FOOT COPPER CLAD GROUND ROD - WITH 10 GAUGE NON-INSULATED GROUND WIRE CONNECTED TO GROUND TERMINAL BLOCK

FINISH GRADE

DEPTH PER ELECTRICAL CODE

VENTS WITH BAFFLE

3 POINT LATCH WITH LOCKABLE HANDLE

2-INCH MALE ADAPTER WITH LOCK RING

2-INCH SCH. 40 P.V.C. SLEEVE WITH 2" SWEEP FOR CONTROL WIRES TO MAINLINE TRENCH. SECURE TO WALL WITH CONDUIT STRAP TOP AND BOTTOM.

TO MAINLINE TRENCH (INSTALL WIRES IN CONDUIT IF NOT IN MAINLINE TRENCH)

NOTES:

1. POWER SOURCE FOR CONTROLLER TO BE HARD WIRED FROM CIRCUIT BREAKER MOUNTED INSIDE CABINET TO CONTROLLER.
2. LOCATION OF POWER SOURCE TO BE NOTED ON CIRCUIT BREAKER PANEL.
3. REMOTE CONTROL VALVES FOR D.C. SCORPIO APPLICATIONS MUST HAVE D.C. LATCHING SOLENOIDS AND APPROVED SOLAR PANEL FOR POWER SOURCE.
4. MIDLAND NARROW BAND RADIO #2845 G TO BE INSTALLED WITH SCORPIO CONTROLLER.
5. INSTALL ONLY ONE CONTROL VALVE WIRE PER CONTROLLER OUTPUT.
6. UHF RADIO TO BE TUNED TO C.O.S. FREQUENCIES. CONTACT IRRIGATION DEPARTMENT FOR INFORMATION (480-312-2189)
7. POWER SOURCE TO BE PROVIDED BY CONTRACTOR FOLLOWING NEC REQUIREMENTS. INSTALLATION TO BE INSPECTED AND APPROVED BY COS INSPECTOR. INSTALL METAL ADDRESS LABELS TO OUTSIDE DOOR OF IRRIGATION CONTROLLER CABINETS FOR ALL CONTROLLERS RECEIVING NON-METERED POWER SUPPLY.

DETAIL NO.
2633

City of Scottsdale
Standard Details

APPROVED BY:
Scottsdale Standards & Specifications Committee

SCORPIO WALL MOUNTED CONTROLLER

DETAIL NO.
2633

REVISED 3/7/12

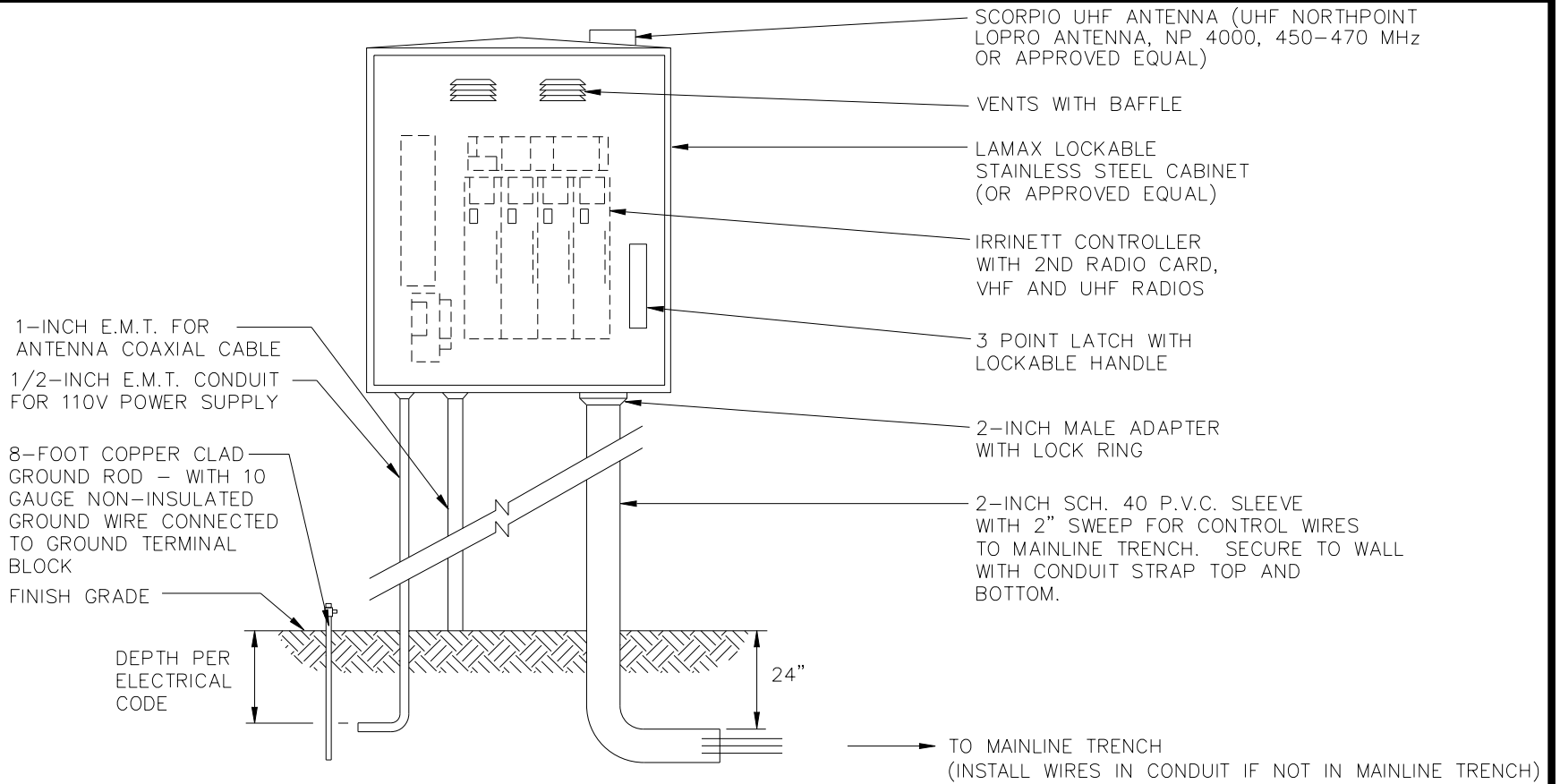

NOTE:

1. POWER SOURCE FOR CONTROLLER TO BE HARD WIRED FROM CIRCUIT BREAKER MOUNTED INSIDE CABINET TO CONTROLLER.
2. LOCATION OF POWER SOURCE TO BE NOTED ON CIRCUIT BREAKER PANEL.
3. INSTALL ONLY ONE CONTROL VALVE WIRE PER CONTROLLER OUTPUT.
4. VHF AND UHF RADIOS TO BE TUNED TO C.O.S. FREQUENCIES. CONTACT IRRIGATION DEPARTMENT FOR INFORMATION (480-312-2189)
5. POWER SOURCE TO BE PROVIDED BY CONTRACTOR FOLLOWING NEC REQUIREMENTS. INSTALLATION TO BE INSPECTED AND APPROVED BY COS INSPECTOR. INSTALL METAL ADDRESS LABELS TO OUTSIDE DOOR OF IRRIGATION CONTROLLER CABINETS FOR ALL CONTROLLERS RECEIVING NON-METERED POWER SUPPLY.
6. ANTENNA TYPE, MAST AND MOUNTING INSTALLATION TO BE APPROVED BY COS IRRIGATION DEPARTMENT.

DETAIL NO.
2634

City of Scottsdale
Standard Details

APPROVED BY:
Scottsdale Standards & Specifications Committee

IRRINET WALL MOUNTED CONTROLLER

DETAIL NO.
2634

REVISED 05/02/08

NOTES:

1. INSTALL WIRE OF APPROPRIATE GAUGE, CONNECTORS, SEALANT, AND ADAPTORS PER MANUFACTURERS INSTRUCTIONS.
2. D.C. LATCHING SOLENOIDS ON REMOTE CONTROL VALVES TO BE COMPATIBLE WITH CONTROLLER.
3. MASTER VALVE TO BE INSTALLED AND WIRED TO CONTROLLER. RAINBIRD GB/PESB VALVE, SAME SIZE AS MAINLINE INSTALLED PER COS DETAIL #2654 (REMOTE CONTROL VALVE) WITH DC LATCHING SOLENOID COMPATIBLE WITH CONTROLLER.
4. PROGRAMMING/ACCESS KEY TO BE SUPPLIED WITH CONTROLLER.
5. INSTALL MANUFACTURERS STAINLESS STEEL ENCLOSURE FOR CONTROLLER.
6. PROVIDE 12" EXANSION COIL FOR EACH WIRE SPLICE INSIDE SPLICE BOX WHEN SPLICES ARE REQUIRED BY MANUFACTURER.
7. THE CONTROLLER SHALL BE SECURED INSIDE THE MANUFACTURES STAINLESS STEEL ENCLOSURE IF NOT INSTALLED INSIDE THE BACKFLOW PREVENTOR ENCLOSURE.

CARSON / BROOKS 10-INCH ROUND VALVE BOX WITH LOCKING "T" STYLE COVER.
(SUPPLY WITH STAINLESS STEEL BOLTS)

EPOXY FILLED TWO PIECE CYLINDER WIRE CONNECTOR

BRICK PAVER (1 OF 3)

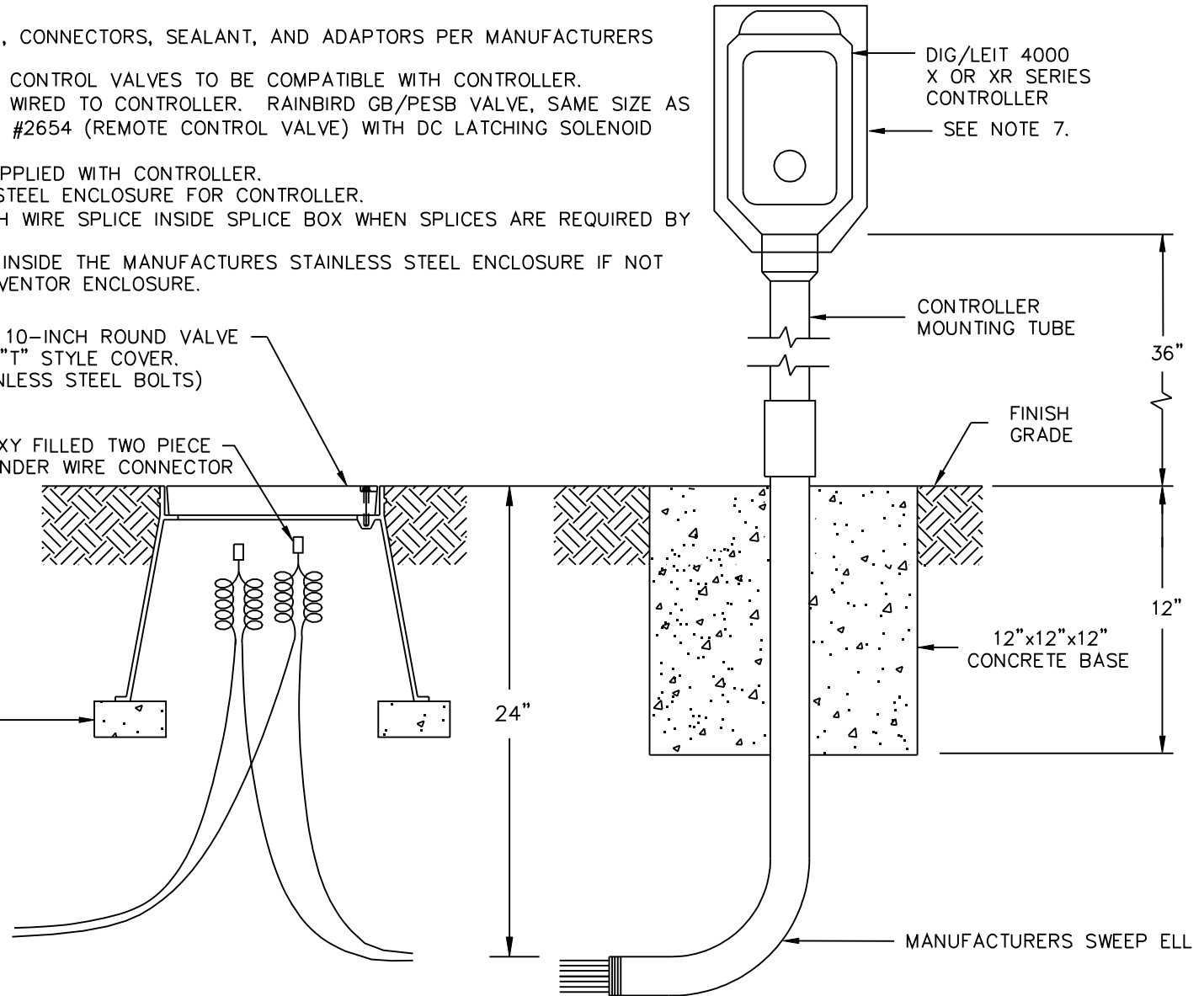

DETAIL NO.
2635-1

City of Scottsdale
Standard Details

APPROVED BY:
Scottsdale Standards &
Specifications Committee

SOLAR CONTROLLER

DETAIL NO.
2635-1

REVISED 3/1/12

NOTES:

1. INSTALL WIRING OF APPROPRIATE GAUGE, CONNECTORS, SEALANT, AND ADAPTORS PER MANUFACTURERS INSTRUCTIONS.
2. INSTALL CONTROL WIRES, SPLICES, AND MOUNTING COLUMN AS FURNISHED/SPECIFIED BY THE CONTROLLER MANUFACTURER.
3. LABEL ALL WIRES IN CONTROLLER.
4. D.C. LATCHING SOLENOIDS ON REMOTE CONTROL VALVES TO BE COMPATIBLE WITH CONTROLLER.
5. MASTER VALVE TO BE INSTALLED AND WIRED TO CONTROLLER. RAINBIRD GB/PESB VALVE, SAME SIZE AS MAINLINE INSTALLED PER COS DETAIL #2654 (REMOTE CONTROL VALVE) WITH DC LATCHING SOLENOID COMPATIBLE WITH CONTROLLER.
6. REFER TO COS DET 2354 FOR ADDITIONAL BACKFLOW PREVENTION DEVICE DETAILS.
7. PROGRAMMING/ACCESS KEY TO BE PROVIDED WITH CONTROLLER.
8. PROVIDE 12" EXANSION COIL FOR EACH WIRE SPLICE INSIDE SPLICE BOX WHEN SPLICES ARE REQUIRED BY MANUFACTURER.

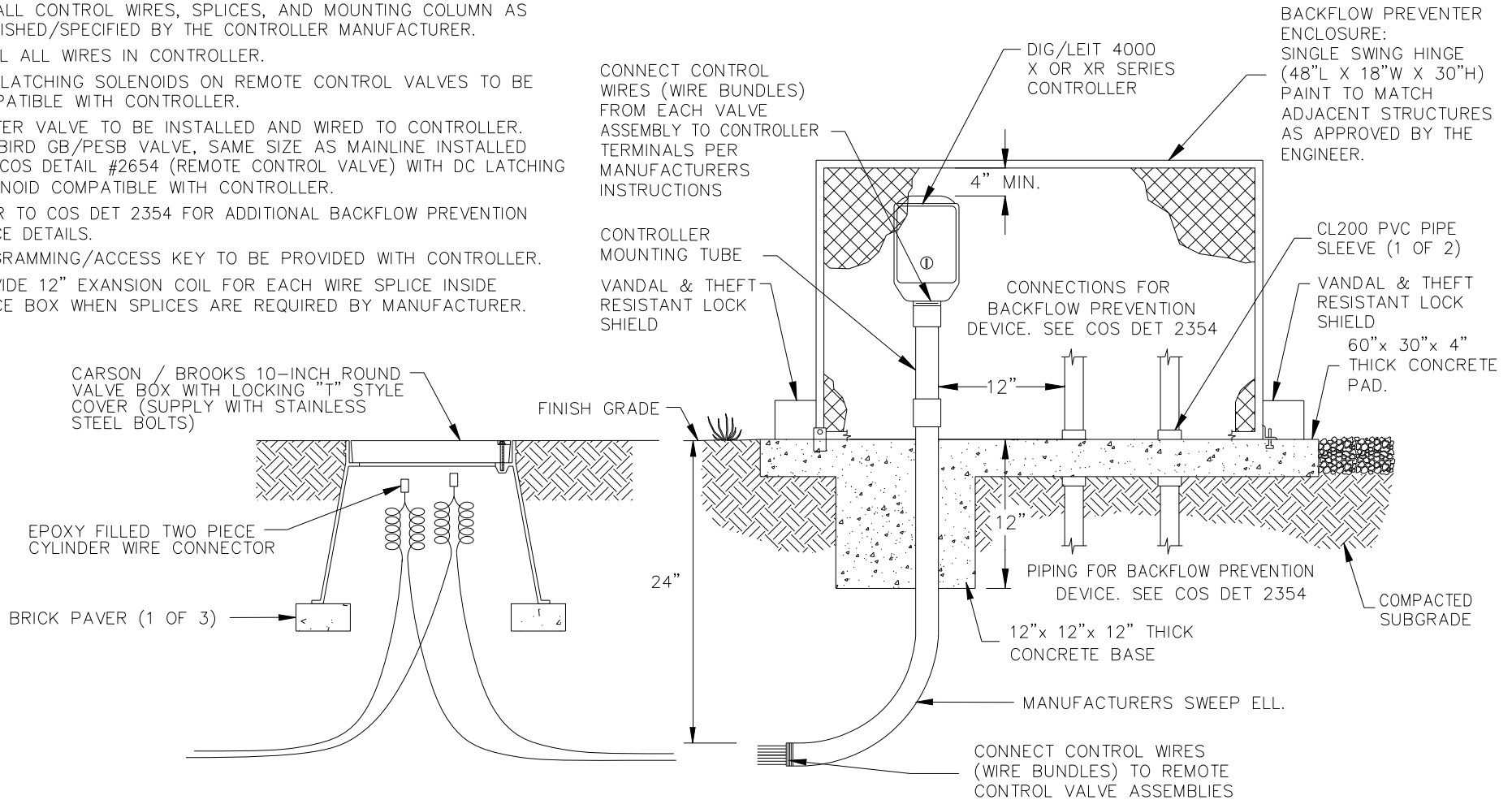

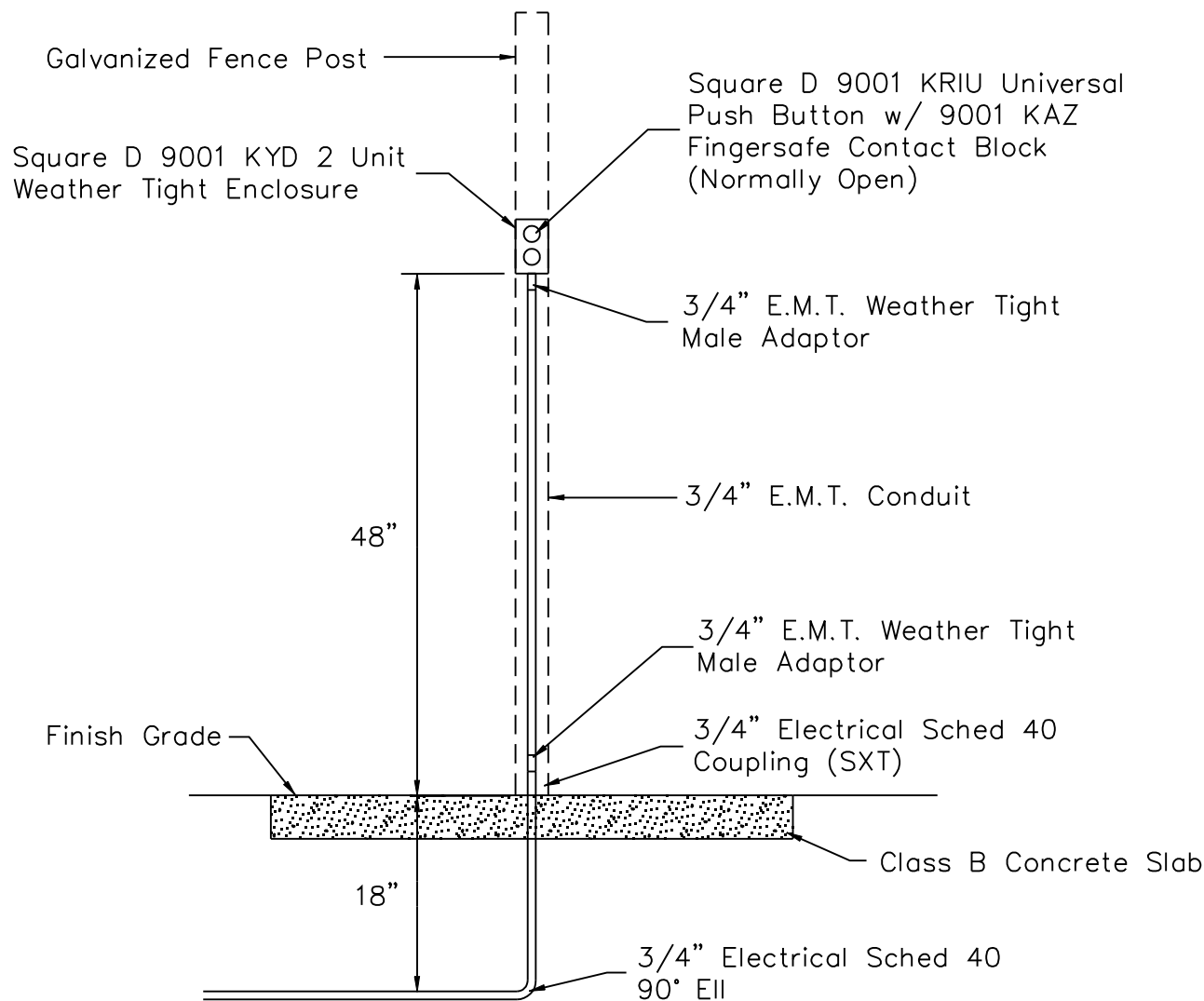

NOTES:

1. Install #14 ga. irrigation control wire.
2. Install one control wire per push button. Control wire to be different color from all other irrigation control wires.
3. Common wire (#12 ga) for push buttons shall be a separate common wire and not part of the irrigation control valve common wire.
4. Push button common wire to have color stripe matching push button control wire. The common wire may be shared by other push buttons.
5. Attach push button enclosure to galvanized post with two self-tapping hex head screws.
6. For other configurations/applications, contact Irrigation Dept 480-312-2189.
7. Label control wires inside enclosure and at controller to differentiate their functionality.

DETAIL NO.
2636

**City of Scottsdale
Standard Details**

APPROVED BY:
**Scottsdale Standards &
Specifications Committee**

IRRIGATION PUSH BUTTON CONTROL

DETAIL NO.
2636

REVISED 2/21/12

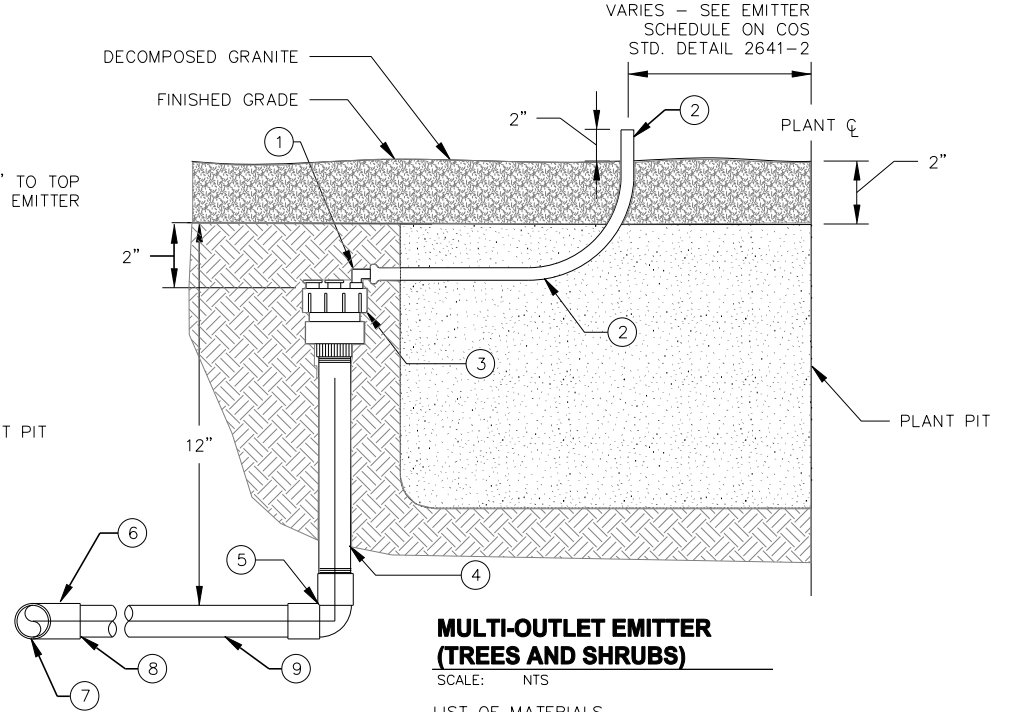
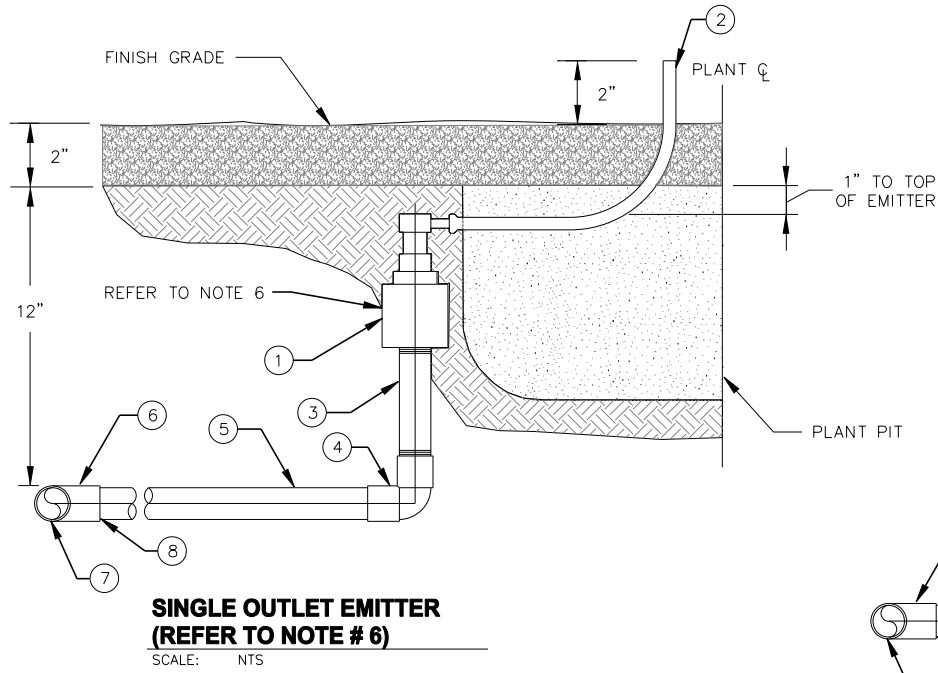

LIST OF MATERIALS

- ① BOWSMITH SL 200 SERIES SINGLE PORT EMITTER OR APPROVED EQUAL. LOCATE ON UPHILL SIDE OF PLANT CENTERLINE
- ② 1/4" POLYETHYLENE FLEX HOSE EMITTER TUBING (6' MAX.)
- ③ 1/2" X 6" SCH 80 TBE NIPPLE
- ④ 1/2" OR 3/4" PVC SCH 40 90° ELBOW - SXT REDUCING AS NECESSARY
- ⑤ 1/2" PVC CL 315 PIPE OR 3/4" CL 200
- ⑥ PVC SCH 40 FITTING
- ⑦ PVC CL 315 FOR 1/2" LATERALS, PVC CL 200 FOR LATERALS GREATER THAN 1/2"
- ⑧ INSTALL BUSHING AS REQUIRED

NOTES:

- 1. PIPE CEMENT & PRIMER SHALL BE USED ON RIGID PIPE CONNECTIONS. TEFLON TAPE SHALL BE USED FOR ALL PIPE THREAD CONNECTIONS.
- 2. POLYETHYLENE EMITTER TUBING EMISSION POINTS SHALL BE EQUALLY SPACED AND LOCATED TO DIRECT WATER FLOW TO THE PERIMETER OF THE DRIP LINE.
- 3. NUMBER OF OPENINGS AND EMITTER TUBES REQUIRED IS BASED ON PLANT SIZE. (SEE COS STD. DET. 2641-2)
- 4. MAXIMUM EMITTER TUBING LENGTH = 6 FEET.
- 5. NO EMITTER LATERALS OR PIPING SHALL BE INSTALLED THROUGH OR BENEATH PLANT PITS. MINIMUM DISTANCE BETWEEN PLANT PIT PERIMETER AND PIPING SHALL BE 12".
- 6. MULTI OUTLET EMITTERS WILL USE A MIN. OF TWO OUTLETS, PLANTS THAT ARE NOT WITHIN A 6' RADIUS OF EACH OTHER SHALL BE IRRIGATED BY SINGLE OUTLET EMITTERS.

LIST OF MATERIALS

- ① SWIVEL OUTLET 90° ELBOW
- ② 1/4" POLYETHYLENE FLEX HOSE EMITTER TUBING (6' MAX.)
- ③ BOWSMITH ML 200 SERIES MULTI-PORT EMITTER OR APPROVED EQUAL. LOCATE ON UPHILL SIDE OF PLANT CENTERLINE
- ④ 1/2" X 6" SCH 80 NIPPLE TBE
- ⑤ 1/2" OR 3/4" PVC SCH 40 90° ELBOW - SXT REDUCING AS NECESSARY
- ⑥ PVC SCH 40 FITTING
- ⑦ PVC CL 315 FOR 1/2" LATERALS, PVC CL 200 FOR LATERALS GREATER THAN 1/2"
- ⑧ INSTALL BUSHING AS REQUIRED
- ⑨ 1/2" PVC CL315 PIPE OR 3/4" CL 200

DETAIL NO.
2641-1

**City of Scottsdale
Standard Details**

APPROVED BY:
**Scottsdale Standards &
Specifications Committee**

SINGLE & MULTI-OUTLET EMITTERS

DETAIL NO.
2641-1

REVISED 2/21/12

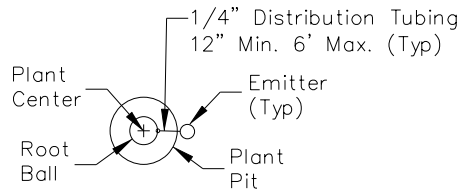

**SHRUB EMITTER
SINGLE OUTLET**

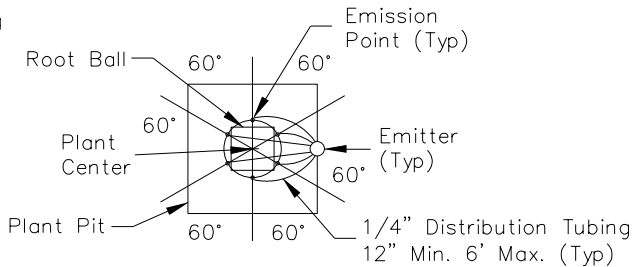

**TREE EMITTER – MULTI OUTLET
15 GAL. TO 42” BOX TREES**
(SEE EMITTER SCHEDULE)

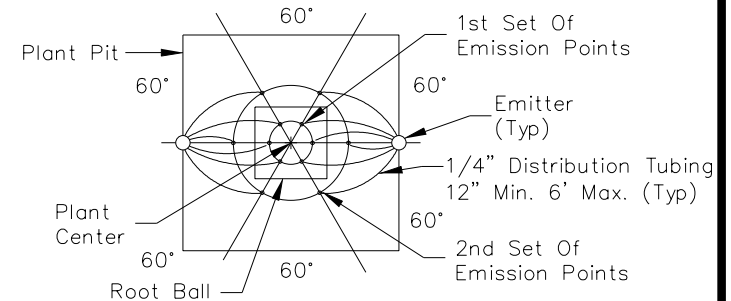

**TREE EMITTER – MULTI OUTLET
48” BOX TO 60” BOX TREES**
(SEE EMITTER SCHEDULE)

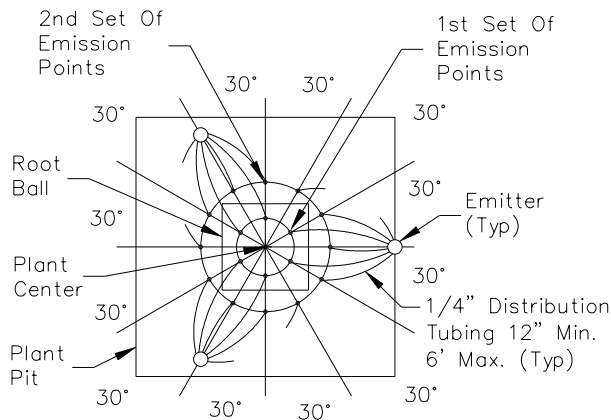

**TREE EMITTER – MULTI OUTLET
66” BOX TO 84” BOX TREES**
(SEE EMITTER SCHEDULE)

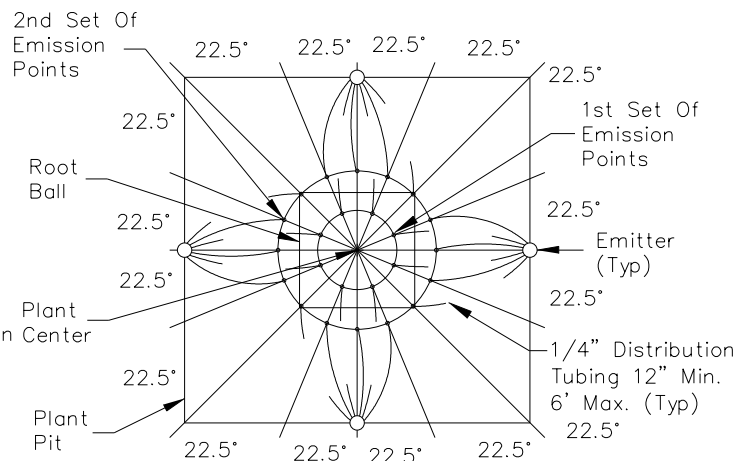

**TREE EMITTER – MULTI OUTLET
96” BOX TREES**
(SEE EMITTER SCHEDULE)

EMITTER SCHEDULE			
Tree Size	Number Of Multi Outlet Emitters – Outlet Quantity = Emitter GPH Total	Distance From Trunk	
		1st Set Of Emission Points	2nd Set Of Emission Points
15 Gal.	1–2 GPH=12 GPH	3 @ 12”	
24” Box	1–2 GPH=12 GPH	4 @ 18”	
30” Box	1–2 GPH=12 GPH	6 @ 21”	
36” Box	1–2 GPH=12 GPH	6 @ 24”	
42” Box	1–2 GPH=12 GPH	6 @ 27”	
48” Box	2–2 GPH=24 GPH	6 @ 12”	4 @ 42”
54” Box	2–2 GPH=24 GPH	6 @ 15”	5 @ 45”
60” Box	2–2 GPH=24 GPH	6 @ 18”	6 @ 48”
66” Box	3–2 GPH=36 GPH	6 @ 24”	12 @ 54”
72” Box			
78” Box	3–2 GPH=36 GPH	6 @ 30”	12 @ 60”
84” Box			
≥ 90” Box	4–2 GPH=48 GPH	8 @ 33”	16 @ 66”

DETAIL NO.
2641-2

**City of Scottsdale
Standard Details**

APPROVED BY:
**Scottsdale Standards &
Specifications Committee**

IRRIGATION EMITTER LAYOUT

DETAIL NO.
2641-2

REVISED 6/12/12

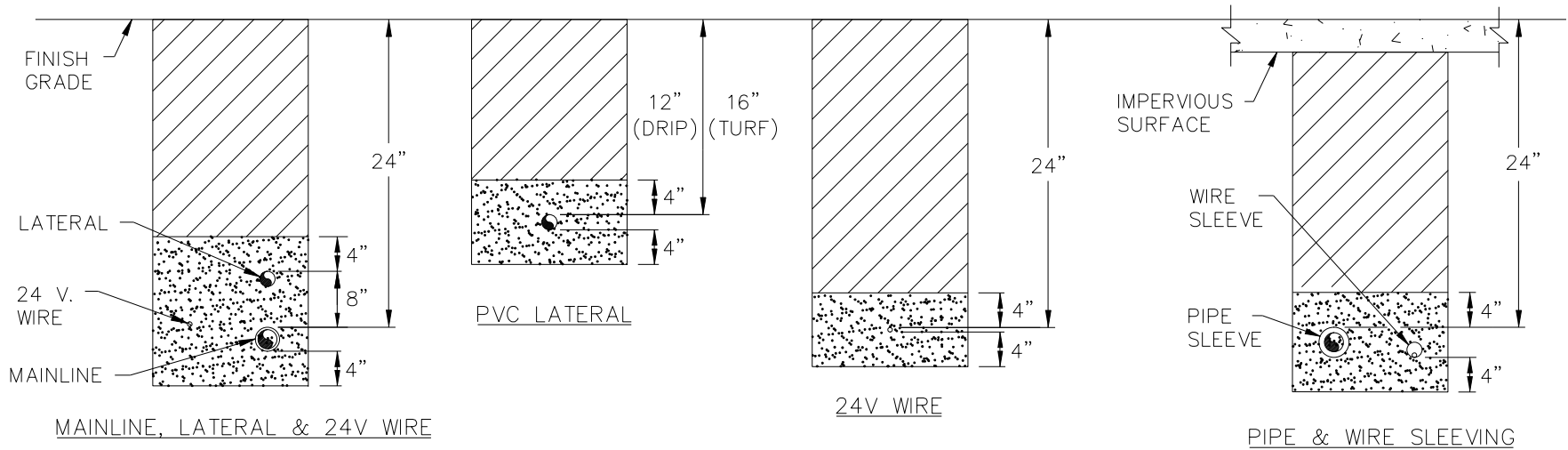

MAINLINE, LATERAL & 24V WIRE

24V WIRE

PIPE & WIRE SLEEVING

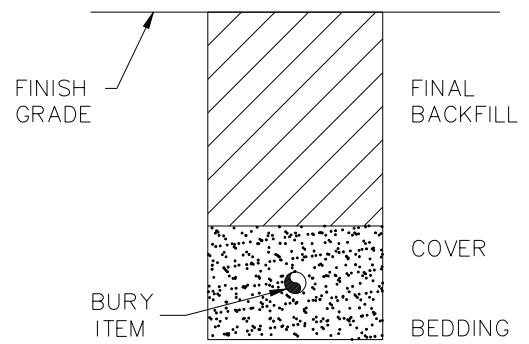

EXCAVATED MATERIAL SHALL BE FINELY SCREENED WITH NO ROCKS LARGER THAN 1".

BEDDING AND COVER MATERIAL SHALL BE TOPSOIL WITH NO ROCKS.

NOTES:

1. BEDDING SHALL BE PLACED AND LEVELED PRIOR TO INSTALLATION OF BURY ITEM.
2. BACKFILL SHALL BE PLACED IN MAXIMUM 6" LIFTS.
3. SLEEVE ALL PIPE AND WIRE SEPARATELY. SLEEVE 2 X DIA. OF PIPE (MIN 2"). ONE PIPE PER SLEEVE. SLEEVES TO BE PRIMED AND SOLVENT WELDED.
4. ALL PIPE TO BE INSTALLED PER MANUFACTURES SPECIFICATIONS WITH PIPE LABELING FACING UP FOR INSPECTION PURPOSES. PROVIDE A MINIMUM OF 2" CLEARANCE TO SIDE OF TRENCH AND BETWEEN PIPES.
5. ALL 120 V. WIRING SHALL BE INSTALLED IN ACCORDANCE WITH LOCAL CODE REQUIREMENTS.
6. TAPE AND BUNDLE IRRIGATION CONTROL WIRES EVERY 10'. PROVIDE LOOSE 20" LOOP AT ALL CHANGES OF DIRECTION OVER 30'.
7. ALL REMOTE CONTROL VALVE WIRING NOT INSTALLED WITH MAINLINE PIPE SHALL BE INSTALLED IN A MINIMUM 2" SCHEDULE 40 GREY ELECTRICAL CONDUIT OR AS APPROVED.
8. "NON-POTABLE" WARNING TAPE TO BE INSTALLED ON ALL PRESSURIZED MAINLINES 12" ABOVE THE PIPE.
9. INSTALL ONE ADDITIONAL SLEEVE SIZED TO MATCH THE LARGEST REQUIRED SLEEVE WITH ENDS TAPED FOR FUTURE USE.
10. SLEEVES TO EXTEND A MINIMUM OF 12" PAST HARDSCAPE PLANTERS, CURBS, SIDEWALKS, ETC. SLEEVES TO BE STAGGERED/OFFSET SO THAT SLEEVE USE IS NOT OBSTRUCTED BY OTHER PIPES.
11. WHERE PRESSURE SUPPLY PIPING IS INSTALLED WITHOUT CONTROL WIRING, A 14 GA. TRACKING WIRE SHALL BE INSTALLED.

DETAIL NO.
2642

City of Scottsdale
Standard Details

APPROVED BY:
Scottsdale Standards & Specifications Committee

IRRIGATION TRENCHING

DETAIL NO.
2642

REVISED: 05/14/08

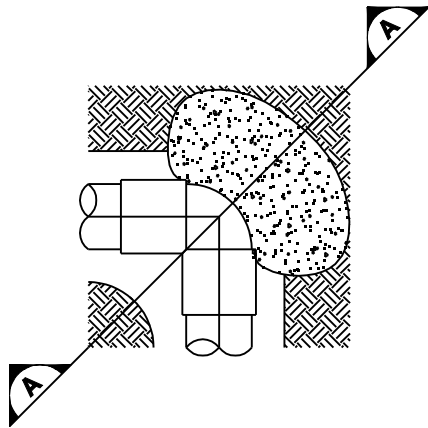

90° ELL

SCALE: NTS

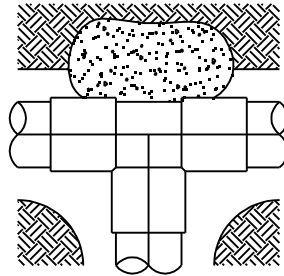

TEE

SCALE: NTS

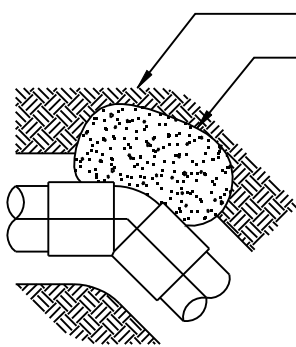

45° ELL

SCALE: NTS

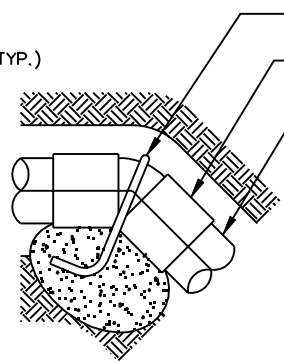

45° ELL (VERTICAL)

SCALE: NTS

PIPE SIZE	MINIMUM THRUST BLOCK AREA (YxW)	
	IRRIGATION PIPE	
	TEE, DEAD END 90° BEND	45°, 22.5°
3"	1 SF	.5 SF
4"	1.5 SF	1 SF
5" & LARGER	2 SF	1.5 SF
	PER MAG DETAIL 380	PER MAG DETAIL 380

NOTES

1. MINIMUM THRUST BLOCK AREAS ARE BASED ON A SOIL BEARING CAPACITY OF 3000 LBS/SF
2. THRUST BLOCK SHALL EXTEND INTO UNDISTURBED SOIL.
3. THRUST BLOCK SHALL BE MAG SECT. 725-CLASS C.
4. MAINLINE PIPING 4" AND LARGER SHALL HAVE MEGA/LUG JOINT RESTRAINTS INSTALLED AT ALL FLOW DIRECTION CHANGES (CONCRETE THRUST BLOCK NOT REQUIRED IF BELL END HARNESS JOINT RESTRAINTS ARE INSTALLED PER MAG 303-1 AND 303-2).

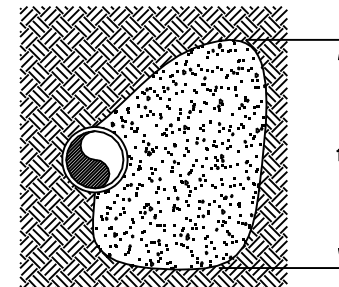
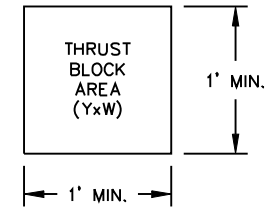

SECTION

A-A

DETAIL NO.
2643

City of Scottsdale
Standard Details

APPROVED BY:
Scottsdale Standards & Specifications Committee

IRRIGATION THRUST BLOCK

DETAIL NO.
2643

REVISED: 2/27/02

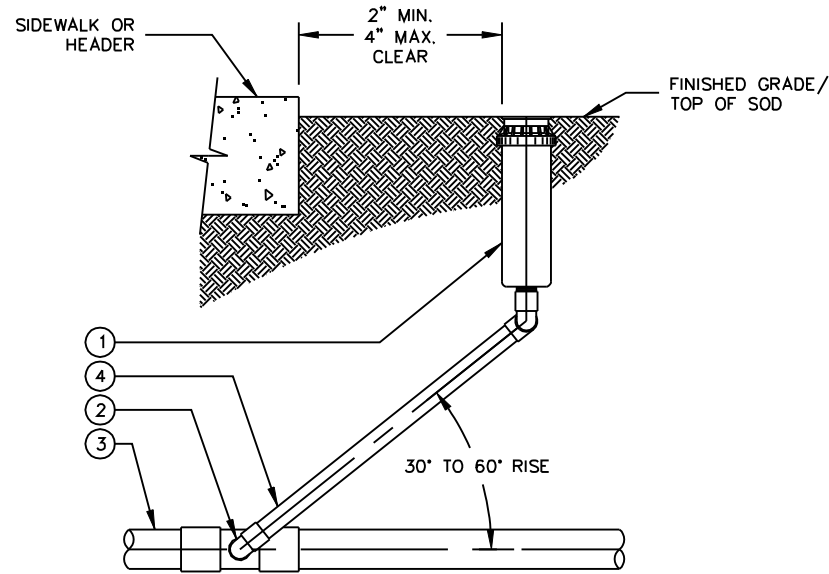

**SWING JOINT ASSEMBLY
ELEVATION**

SCALE: NTS

LIST OF MATERIALS

- ① ROTOR SPRINKLER HEAD
- ② STREET ELL (1 OF 3) SCH 40 PVC
- ③ PVC LATERAL PIPE
- ④ SCH 80 NIPPLE TBE

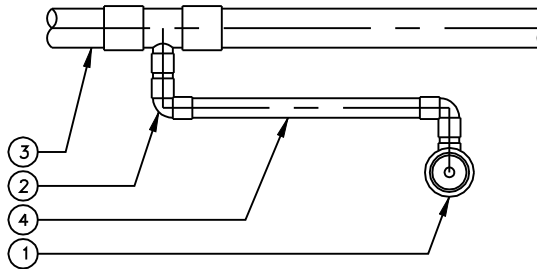

SWING JOINT ASSEMBLY PLAN

SCALE: NTS

NOTES

- 1. SWING JOINT TO BE THE SAME SIZE AS SPRINKLER HEAD INLET.
- 2. NO PRE-FAB SWING JOINTS
- 3. NO MARLEX FITTINGS

**DETAIL NO.
2644**

**City of Scottsdale
Standard Details**

APPROVED BY:
**Scottsdale Standards &
Specifications Committee**

ROTOR SPRINKLER ASSEMBLY

**DETAIL NO.
2644**

REVISED: 2/27/02

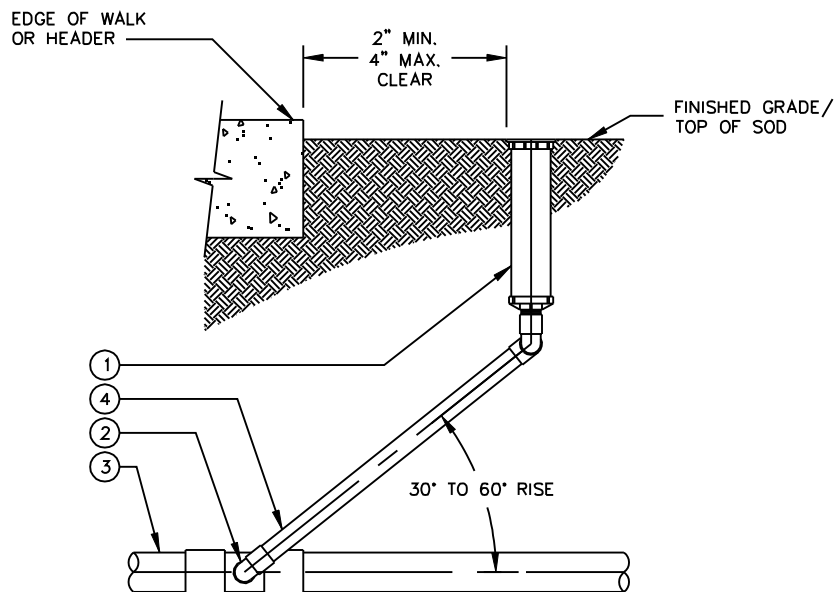

**SWING JOINT ASSEMBLY
ELEVATION**

SCALE: NTS

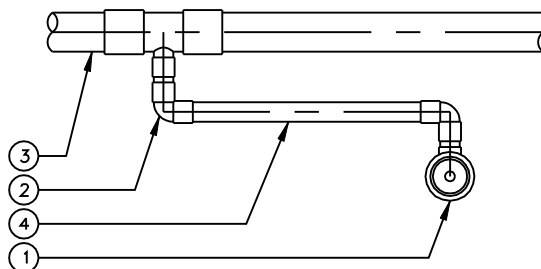

SWING JOINT ASSEMBLY PLAN

SCALE: NTS

LIST OF MATERIALS

- ① 4" POP-UP SPRAY SPRINKLER HEAD
- ② STREET ELL (1 OF 3) SCH 40 PVC
- ③ PVC LATERAL PIPE
- ④ SCH 80 NIPPLE TBE

NOTES

- 1. SWING JOINT TO BE THE SAME SIZE AS SPRINKLER HEAD INLET.
- 2. NO PRE-FAB SWING JOINTS
- 3. NO MARLEX FITTINGS

**DETAIL NO.
2645**

**City of Scottsdale
Standard Details**

APPROVED BY:
**Scottsdale Standards &
Specifications Committee**

POP-UP SPRINKLER ASSEMBLY

**DETAIL NO.
2645**

REVISED: 2/27/02

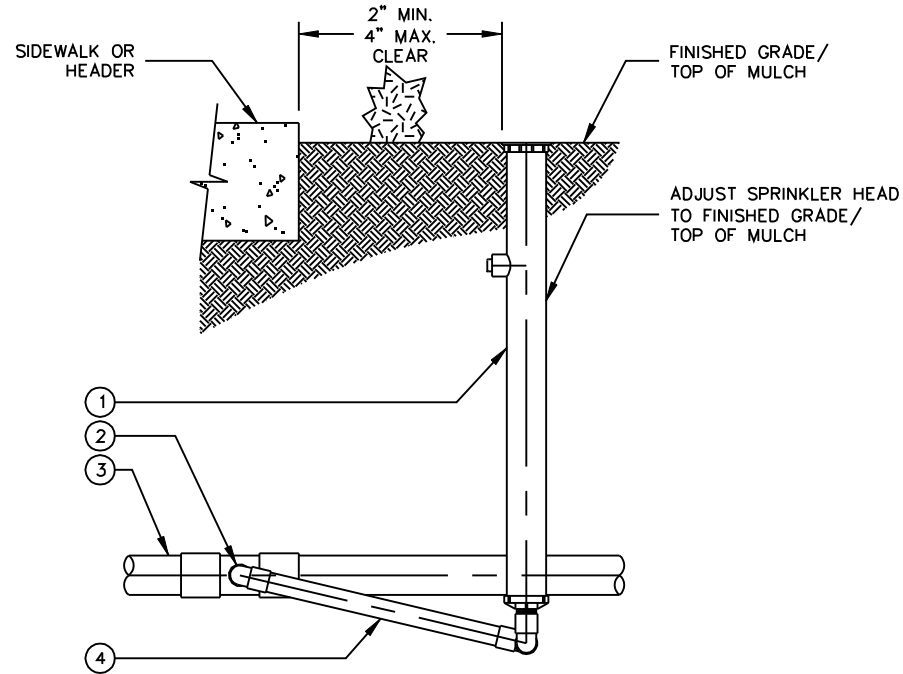

**SWING JOINT ASSEMBLY
ELEVATION**

SCALE: NTS

LIST OF MATERIALS

- ① 12" POP-UP SPRAY SPRINKLER HEAD
- ② STREET ELL (1 OF 3) SCH 40 PVC
- ③ PVC LATERAL PIPE
- ④ SCH 80 NIPPLE TBE

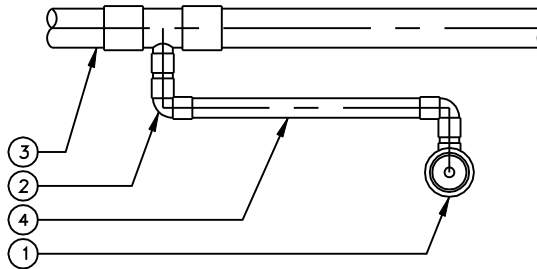

SWING JOINT ASSEMBLY PLAN

SCALE: NTS

NOTES

- 1. SWING JOINT TO BE THE SAME SIZE AS SPRINKLER HEAD INLET.
- 2. SWING JOINT SHALL BE CONNECTED TO BOTTOM OUTLET.
- 3. NO PRE-FAB SWING JOINTS
- 4. NO MARLEX FITTINGS

**DETAIL NO.
2646**

**City of Scottsdale
Standard Details**

APPROVED BY:
**Scottsdale Standards &
Specifications Committee**

SHRUB POP-UP SPRINKLER ASSEMBLY

**DETAIL NO.
2646**

REVISED 3/7/12

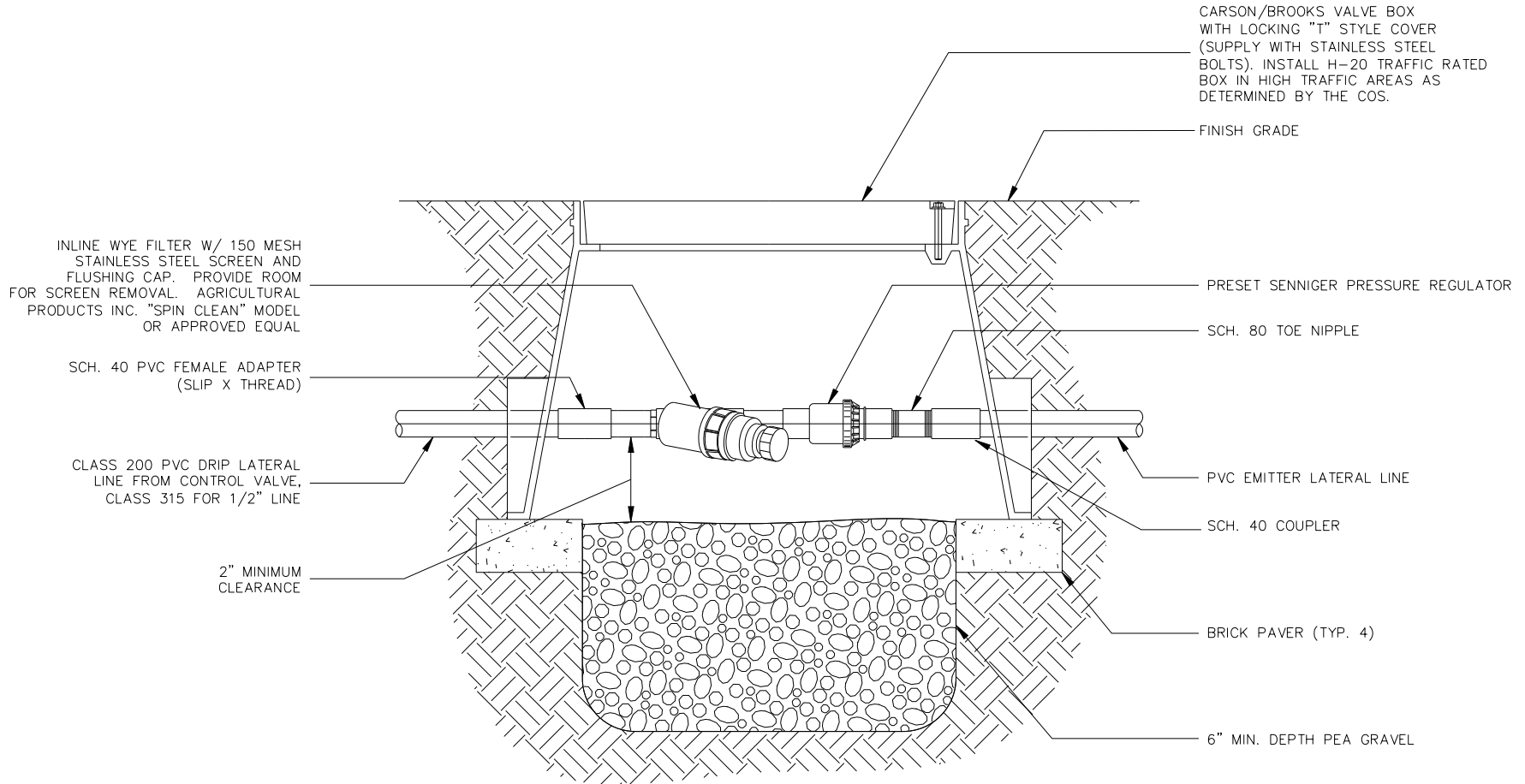

DRIP FILTER & PRESS. REG. ASSEMBLY

SCALE: NTS

DETAIL NO.
2647

**City of Scottsdale
Standard Details**

APPROVED BY:
Scottsdale Standards & Specifications Committee

DRIP FILTER & PRESSURE REGULATOR

DETAIL NO.
2647

REVISED 3/7/12

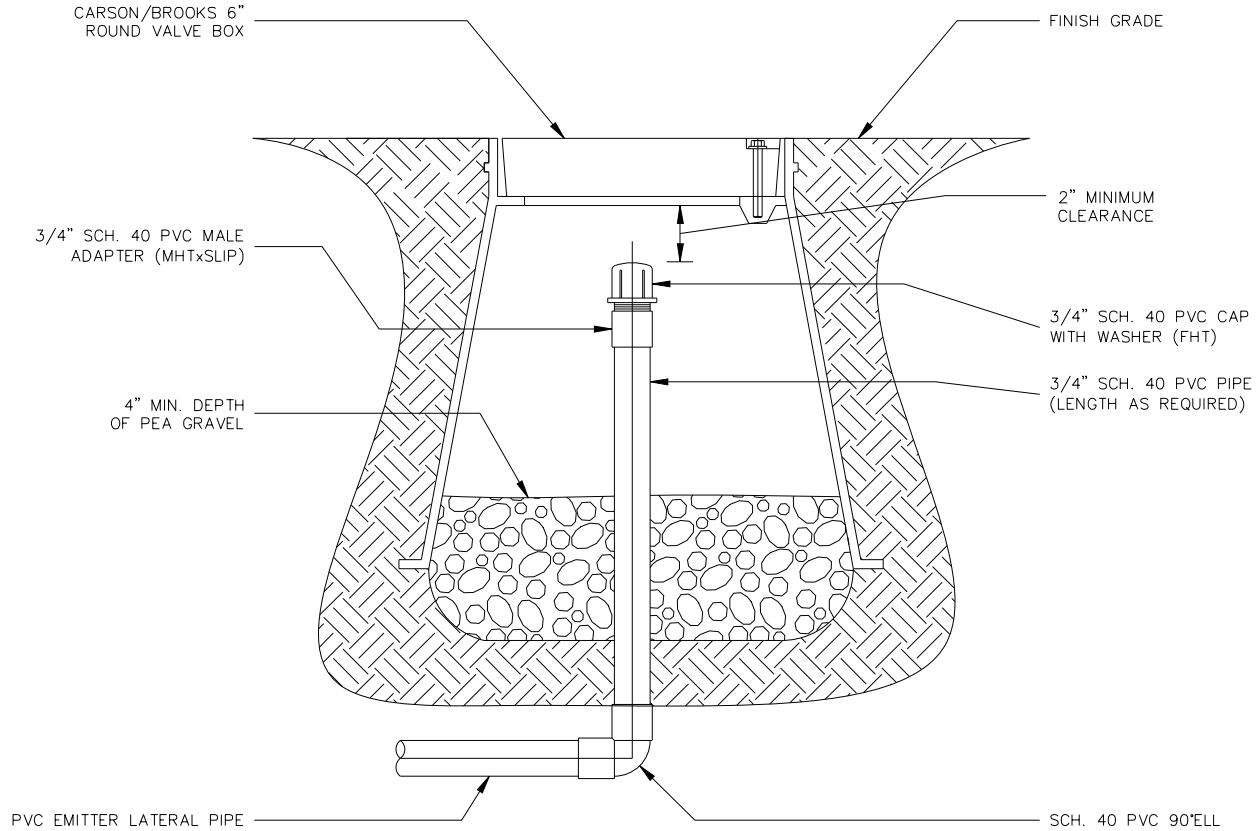

EMITTER FLUSH CAP ASSEMBLY

SCALE: NTS

DETAIL NO.
2648

**City of Scottsdale
Standard Details**

APPROVED BY:
**Scottsdale Standards &
Specifications Committee**

EMITTER FLUSH CAP ASSEMBLY

DETAIL NO.
2648

REVISED: 05/02/08

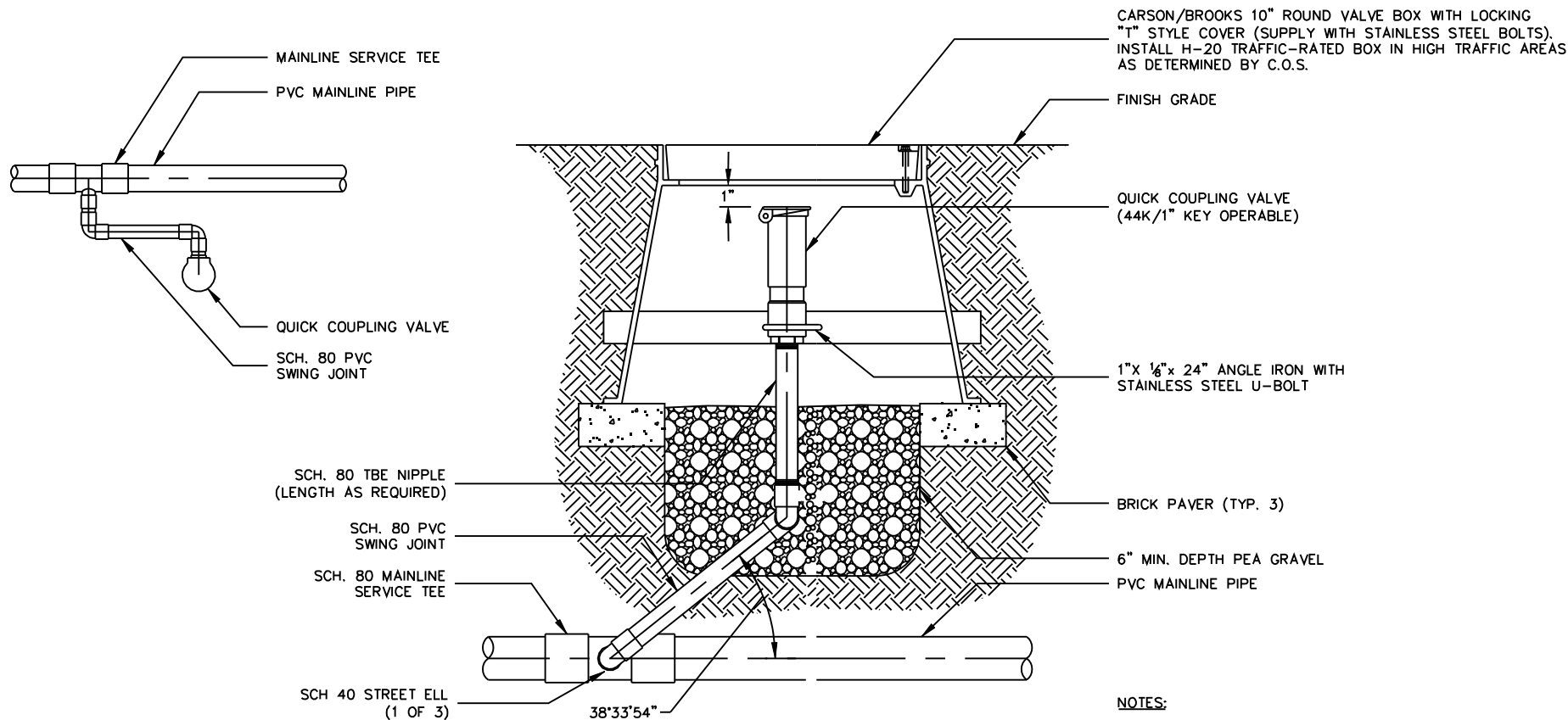

CARSON/BROOKS 10" ROUND VALVE BOX WITH LOCKING "T" STYLE COVER (SUPPLY WITH STAINLESS STEEL BOLTS). INSTALL H-20 TRAFFIC-RATED BOX IN HIGH TRAFFIC AREAS AS DETERMINED BY C.O.S.

FINISH GRADE

QUICK COUPLING VALVE (44K/1" KEY OPERABLE)

1"x 1/8" x 24" ANGLE IRON WITH STAINLESS STEEL U-BOLT

BRICK PAVER (TYP. 3)

6" MIN. DEPTH PEA GRAVEL

PVC MAINLINE PIPE

NOTES:

1. EACH QUICK COUPLER SHALL BE IN A SEPARATE VALVE BOX.
2. SWING JOINT SHALL BE THE SAME SIZE AS QUICK COUPLER VALVE.
3. NO PRE-FAB SWING JOINTS.
4. U-BOLT TO BE SECURED WITH LOCK WASHERS AND BACK-UP LOCKING NUT.

QUICK COUPLER ASSEMBLY

SCALE: NTS

**DETAIL NO.
2649**

**City of Scottsdale
Standard Details**

APPROVED BY:
**Scottsdale Standards &
Specifications Committee**

QUICK COUPLER ASSEMBLY

**DETAIL NO.
2649**

REVISED 3/7/12

NOTE:
1. BALL VALVE SHALL MATCH NOMINAL SIZE OF MAINLINE PIPE.

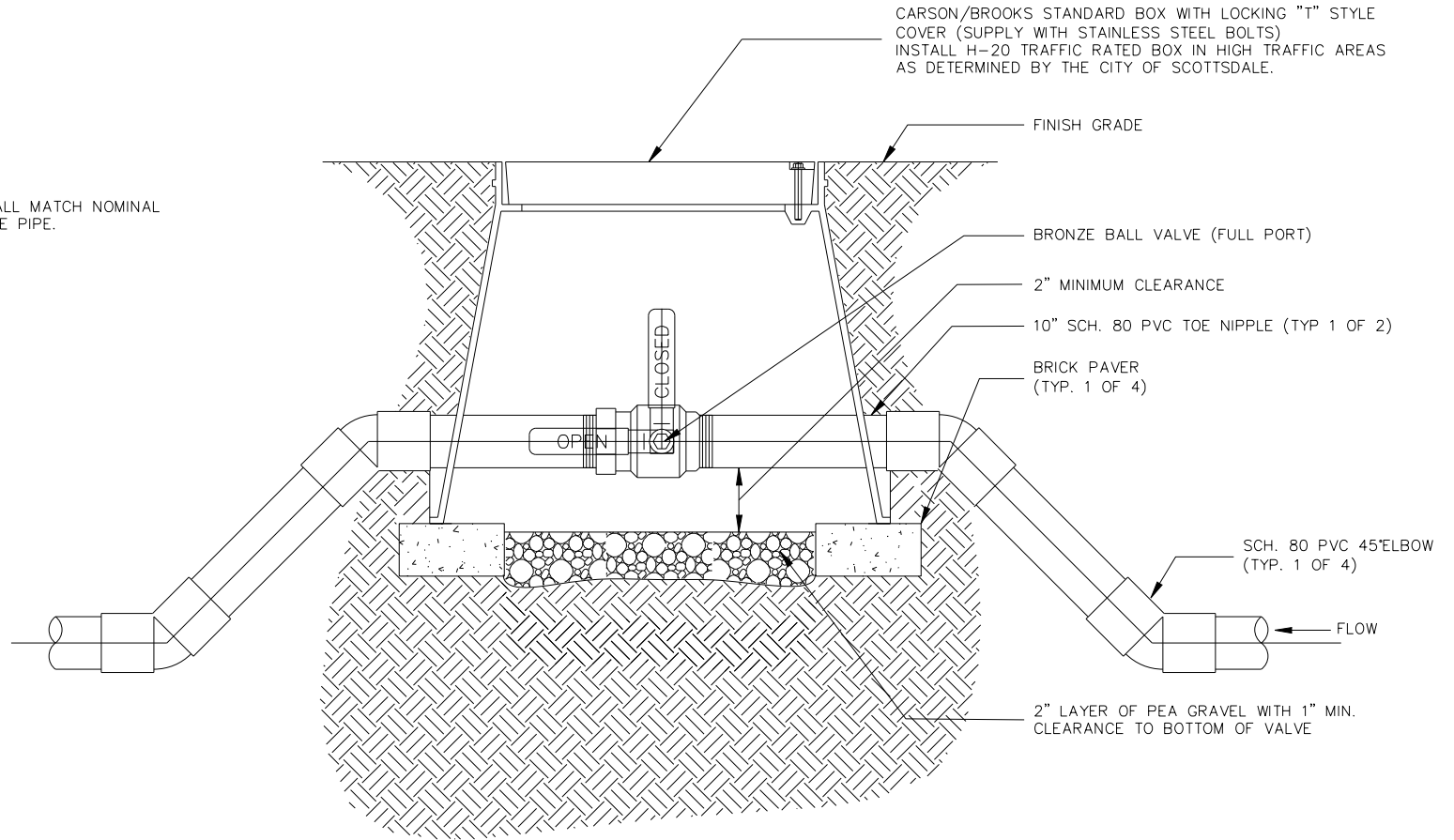

1-1/2" & SMALLER MAINLINE ISOLATION BALL VALVE ASSEMBLY

SCALE: NTS

DETAIL NO.
2650

City of Scottsdale
Standard Details

APPROVED BY:
Scottsdale Standards &
Specifications Committee

1 1/2" & SMALLER MAINLINE BALL VALVE

DETAIL NO.
2650

REVISED: 05/02/08

NOTE:

- 1. GATE VALVE SHALL MATCH NOMINAL SIZE OF MAINLINE PIPE.
- 2. PROTECT VALVE BODY WITH 10MIL PLASTIC PRIOR TO INSTALLATION OF REBAR & SUPPORT BLOCK.

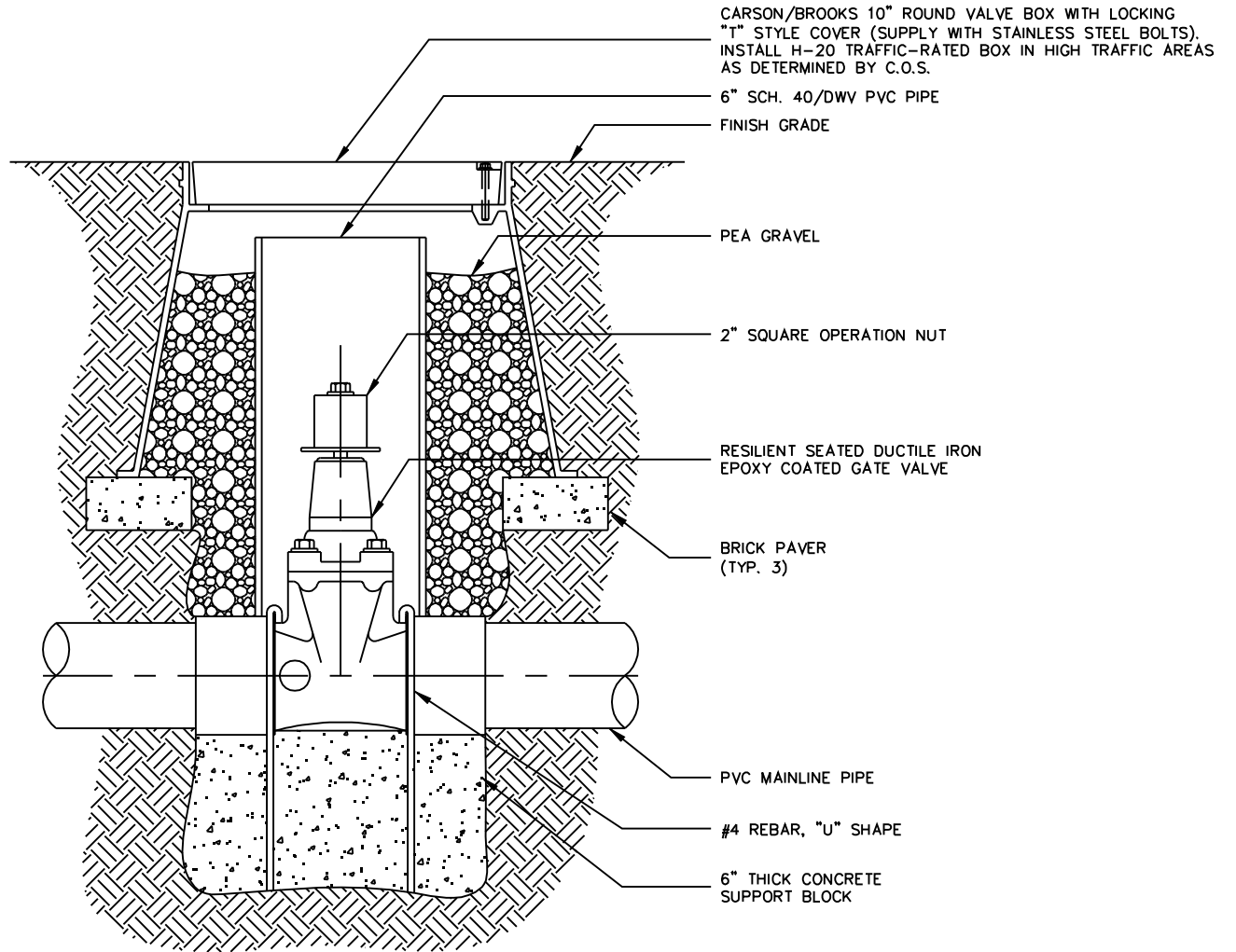

2" & LARGER MAINLINE ISOLATION GATE VALVE ASSEMBLY

SCALE: NTS

**DETAIL NO.
2651**

**City of Scottsdale
Standard Details**

APPROVED BY:
**Scottsdale Standards &
Specifications Committee**

2" & LARGER MAINLINE ISOLATION GATE VALVE

**DETAIL NO.
2651**

REVISED 6/12/12

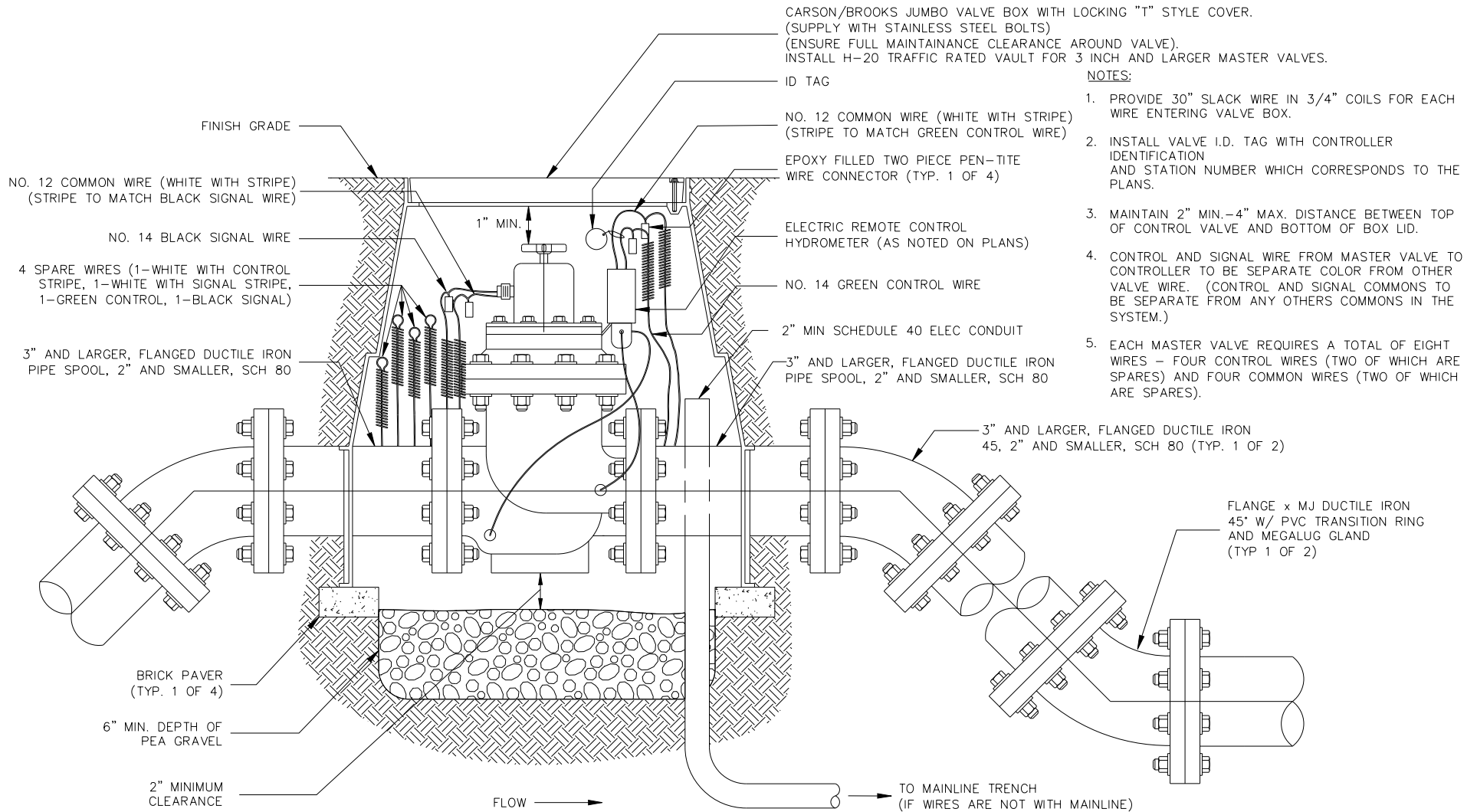

CARSON/BROOKS JUMBO VALVE BOX WITH LOCKING "T" STYLE COVER.
 (SUPPLY WITH STAINLESS STEEL BOLTS)
 (ENSURE FULL MAINTAINANCE CLEARANCE AROUND VALVE).
 INSTALL H-20 TRAFFIC RATED VAULT FOR 3 INCH AND LARGER MASTER VALVES.

- NOTES:**
1. PROVIDE 30" SLACK WIRE IN 3/4" COILS FOR EACH WIRE ENTERING VALVE BOX.
 2. INSTALL VALVE I.D. TAG WITH CONTROLLER IDENTIFICATION AND STATION NUMBER WHICH CORRESPONDS TO THE PLANS.
 3. MAINTAIN 2" MIN.-4" MAX. DISTANCE BETWEEN TOP OF CONTROL VALVE AND BOTTOM OF BOX LID.
 4. CONTROL AND SIGNAL WIRE FROM MASTER VALVE TO CONTROLLER TO BE SEPARATE COLOR FROM OTHER VALVE WIRE. (CONTROL AND SIGNAL COMMONS TO BE SEPARATE FROM ANY OTHERS COMMONS IN THE SYSTEM.)
 5. EACH MASTER VALVE REQUIRES A TOTAL OF EIGHT WIRES - FOUR CONTROL WIRES (TWO OF WHICH ARE SPARES) AND FOUR COMMON WIRES (TWO OF WHICH ARE SPARES).

DETAIL NO.
2653

**City of Scottsdale
Standard Details**

APPROVED BY:
**Scottsdale Standards &
Specifications Committee**

1 1/2" & LARGER MASTER VALVE/FLOW METER

DETAIL NO.
2653

REVISED 6/1212

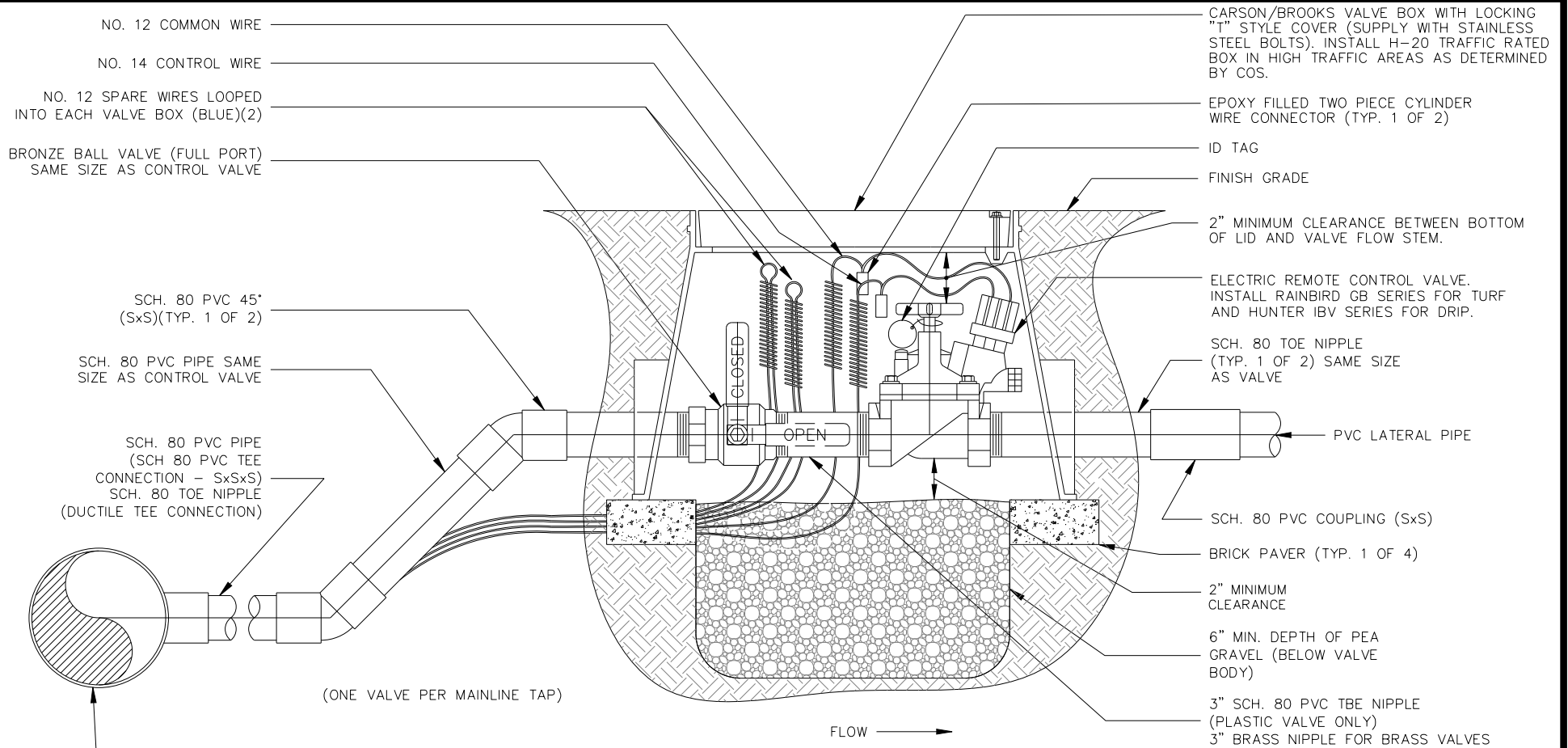

(ONE VALVE PER MAINLINE TAP)

FLOW →

REMOTE CONTROL VALVE ASSEMBLY

SCALE: NTS

NOTES:

1. PROVIDE 30" SLACK WIRE IN 3/4" COILS FOR EACH WIRE ENTERING VALVE BOX.
2. INSTALL VALVE I.D. TAG WITH CONTROLLER IDENTIFICATION AND STATION NUMBER WHICH CORRESPONDES TO THE PLANS.
3. MAINTAIN 2" MIN.-4" MAX. DISTANCE BETWEEN TOP OF CONTROL VALVE AND BOTTOM OF BOX LID.
4. INSTALL D.C. LATCHING SOLENOIDS W/ D.C. CONTROLLERS.
5. FOR BRASS CONTROL VALVES, INSTALL 3" BRASS TBE NIPPLE BETWEEN BALL VALVE AND CONTROL VALVE

DETAIL NO.
2654

**City of Scottsdale
Standard Details**

APPROVED BY:
**Scottsdale Standards &
Specifications Committee**

**REMOTE CONTROL VALVE AND SOLAR
CONTROLLER MASTER VALVE ASSEMBLY**

DETAIL NO.
2654

REVISED: 3/9/05

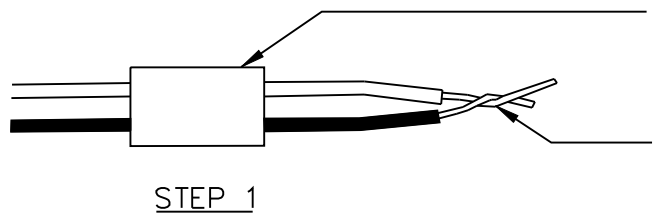

STEP 1

SLIP BASE SOCKET OVER
END OF WIRES

STRIP WIRES APPROX. 5/8" FROM
ENDS - TWIST ENDS TOGETHER

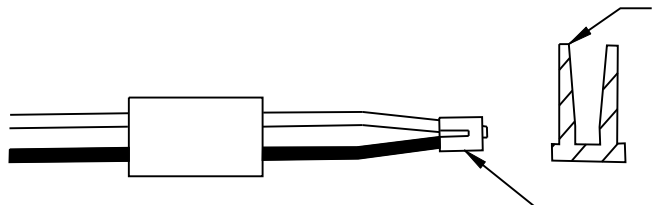

STEP 2

APPLY SEALER TO OUTSIDE OF SEALING
PLUG - FILL CAVITY WITH SEALER

PUT CRIMP SLEEVE OVER WIRE
ENDS - CRIMP SLEEVE AND CUT
OFF EXCESS WIRE

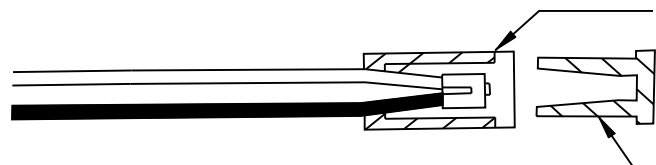

STEP 3

PULL BASE SOCKET OVER WIRE
END AS FAR AS POSSIBLE

PUSH SEALING PLUG INTO
BASE SOCKET

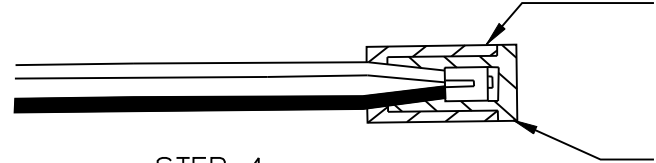

STEP 4

PUSH WIRES TO END OF BASE
SOCKET TO ASSURE COMPLETE
SEALING OF CONNECTION

DRI-SPLICE TYPE WIRE
CONNECTOR

NOTES:

1. FOR WIRE SIZES NO. 14, 12 AND 10, ALL CONNECTIONS IN VALVE BOXES ONLY.
2. INSTALL SPEARS DS-100 DRI-SPLICE CONNECTORS WITH DS-300 SEALANT.

DETAIL NO.
2655

**City of Scottsdale
Standard Details**

APPROVED BY:
**Scottsdale Standards &
Specifications Committee**

TYPICAL IRRIGATION WIRE CONNECTION

DETAIL NO.
2655

REVISED: 4/25/07

WIRE SIZE (AWG)	MAXIMUM NUMBER OF WIRES TO BE INSTALLED IN A SCHEDULE 40 PVC SLEEVE			WIRE SIZE (AWG)
	2"	2-1/2"	3"	
14	25	40	56	14
12	20	33	50	12

NOTE:

1. ALL WIRE SLEEVES TO BE SHC. 40 PVC AND SHALL BE INSTALLED WITH A MINIMUM OFFSET AT THE JOINTS TO PERMIT EASY INSTALLATION AND REMOVAL OF CONTROL AND COMMON WIRES. ALL WIRES SHALL BE INSTALLED IN SLEEVES UNDER THE PAVED AREAS. SLEEVES SHALL EXTEND AT LEAST 12" BEYOND THE EDGES OF THE PAVEMENT. SIZE OF SLEEVES SHALL BE AS SHOWN.

DETAIL NO.
2656

**City of Scottsdale
Standard Details**

APPROVED BY:
**Scottsdale Standards &
Specifications Committee**

IRRIGATION WIRE SLEEVING CHART

DETAIL NO.
2656

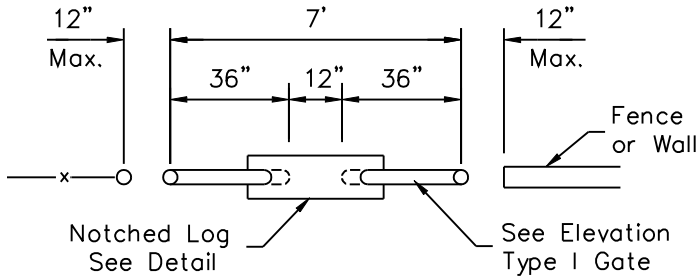

**TYPE I GATE
w/ NOTCHED LOG**

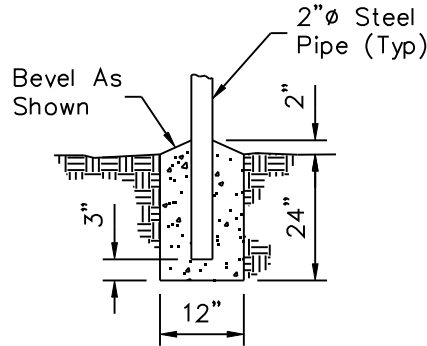

**POST FOOTING
DETAIL**

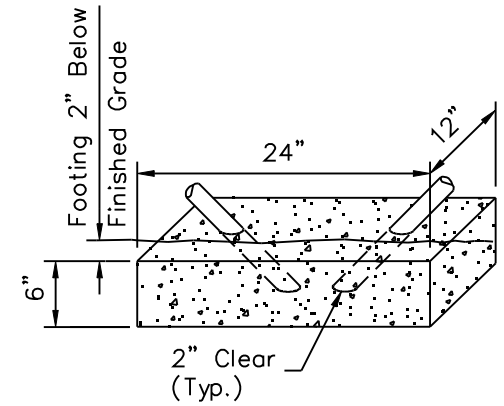

**GATE FOOTING
DETAIL**

NOTES:

1. All Concrete Shall Be Class "B".
2. Paint Rails Per ADOT Specifications. Color Per Plans.
3. Treated Wood Per MAG Section 779.

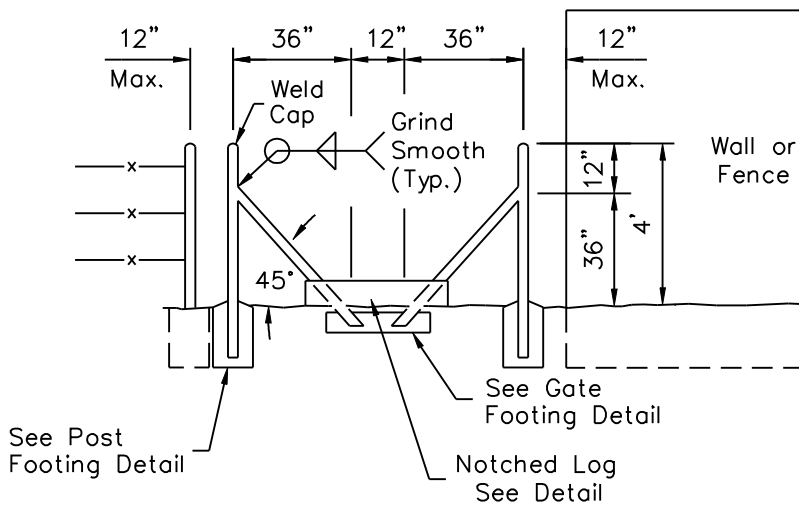

**ELEVATION
TYPE I GATE**

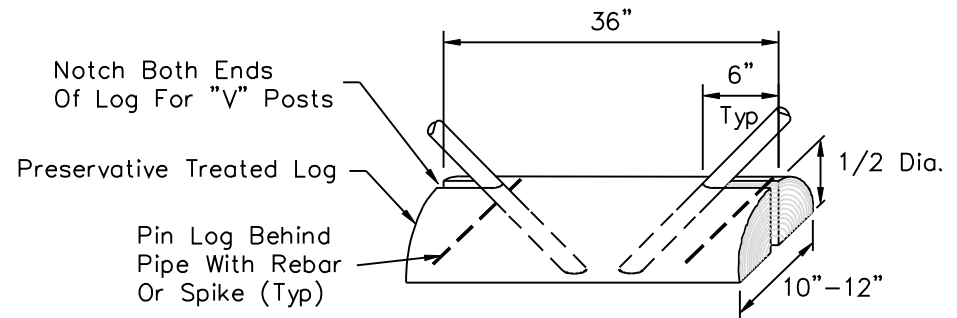

NOTCHED LOG DETAIL

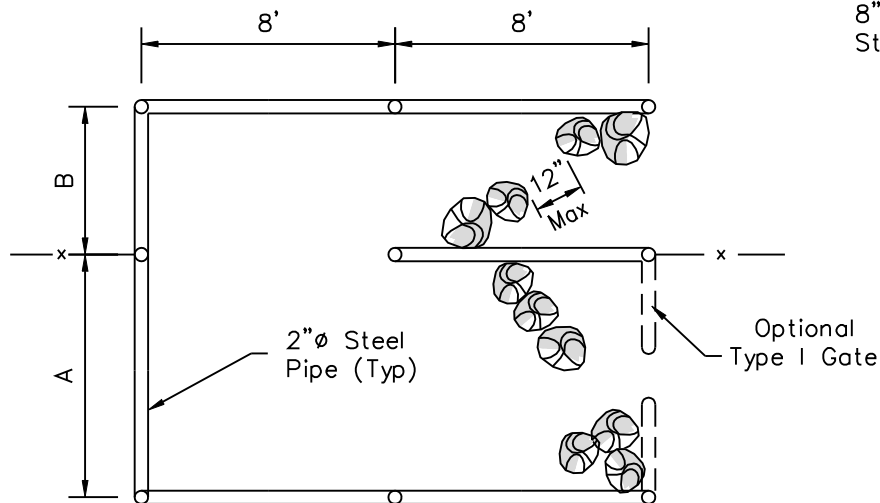

TYPE II GATE

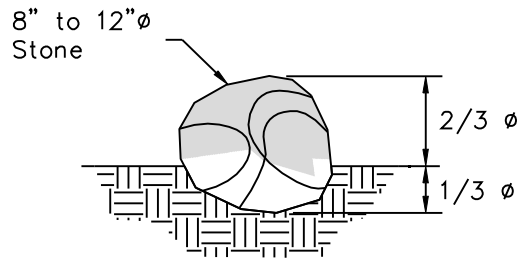

**BURIED STONE
DETAIL**

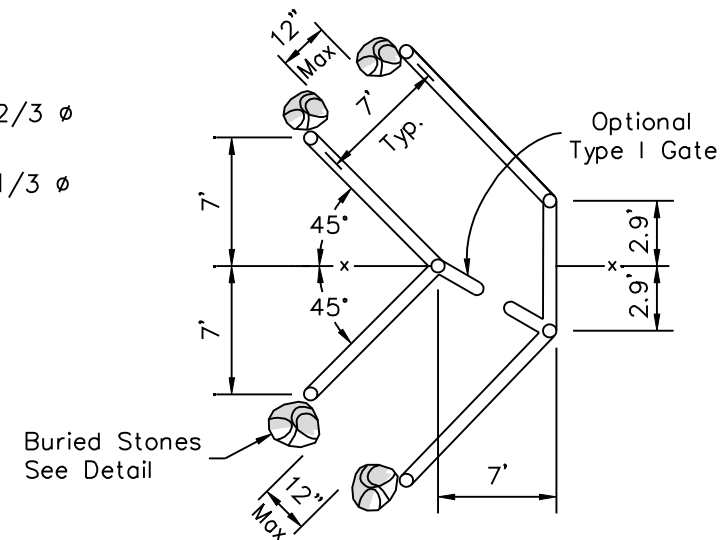

TYPE IV GATE

NOTE:

Gate barriers for Type II, III and IV gates shall be buried stones or Type I gate as shown on plan.

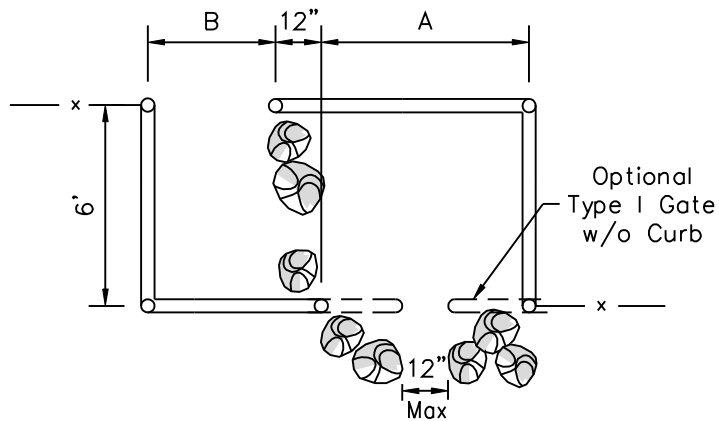

TYPE III GATE

TYPE II and III GATE DIMENSIONS		
GATE BARRIER	A	B
Type I	7'	4'
Buried Rocks	4'	4'

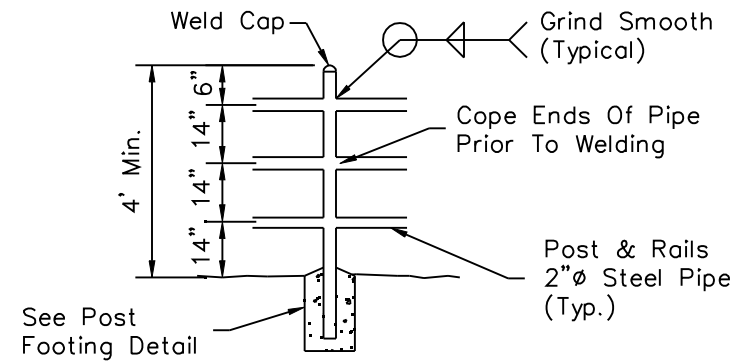

**TYPICAL RAIL ELEVATION
TYPE II, III & IV GATE**

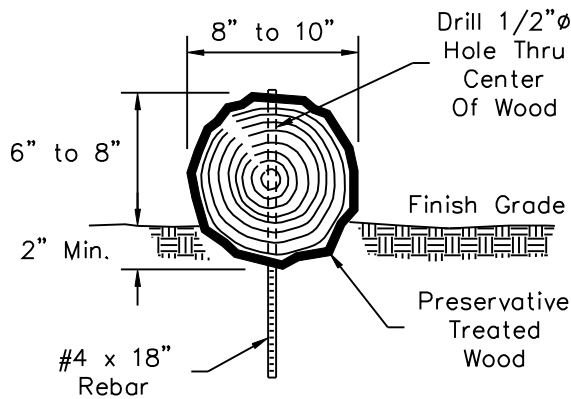

**REBAR SECURED
WOOD BARS**

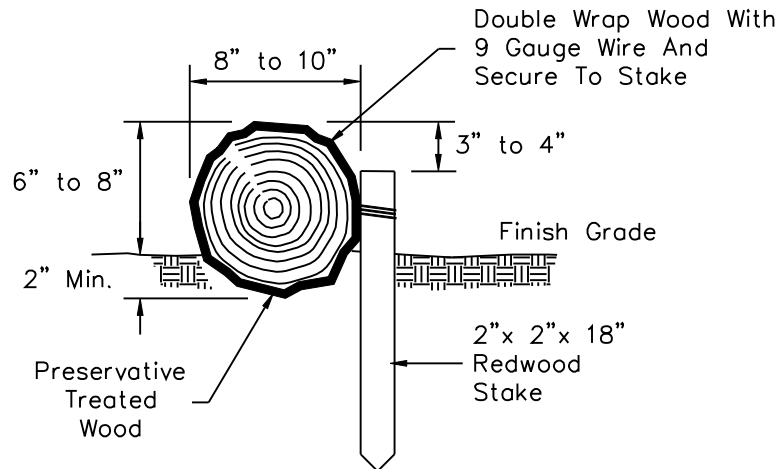

**WIRE SECURED
WOOD BARS**

NOTES:

1. Provide water bars at a maximum 100' interval where trail grade is equal to or greater than 6% and at all locations as shown on plans.
2. Treated wood per MAG Section 779.

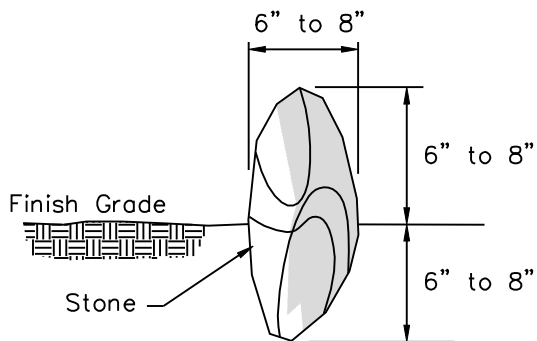

Stagger Stones To Provide
A Continuous Water Bar

STONE BARS

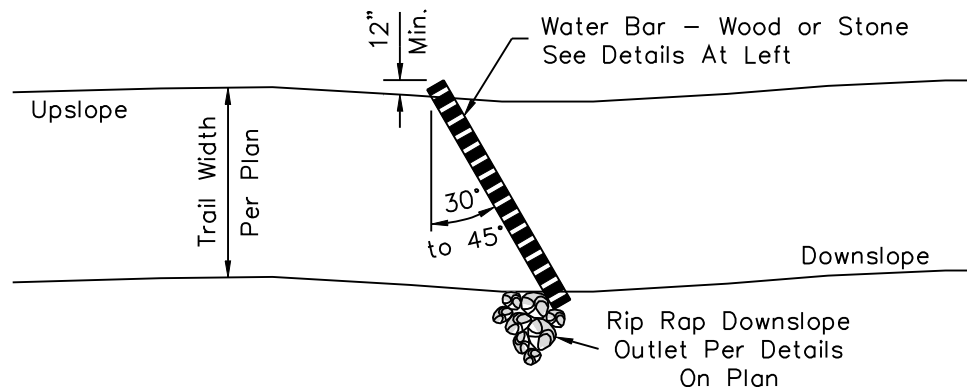

**WATER BARS
PLAN**

DETAIL NO.
2681

**City of Scottsdale
Standard Details**

APPROVED BY:
**Scottsdale Standards &
Specifications Committee**

TRAIL WATER BARS

DETAIL NO.
2681

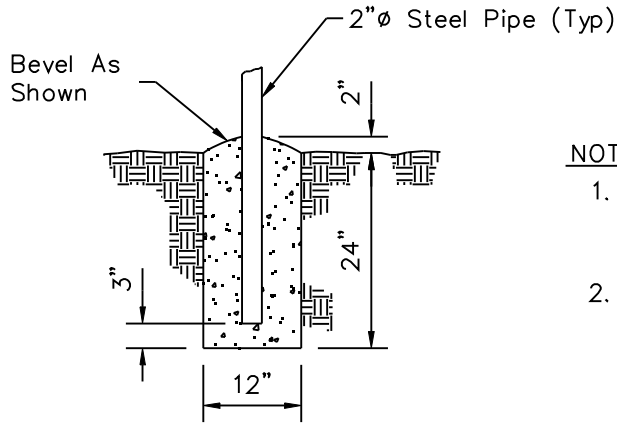

- NOTES:**
1. Paint Rails Per ADOT Specifications. Color Per Plan.
 2. Treated Wood Posts Per MAG Section 779.

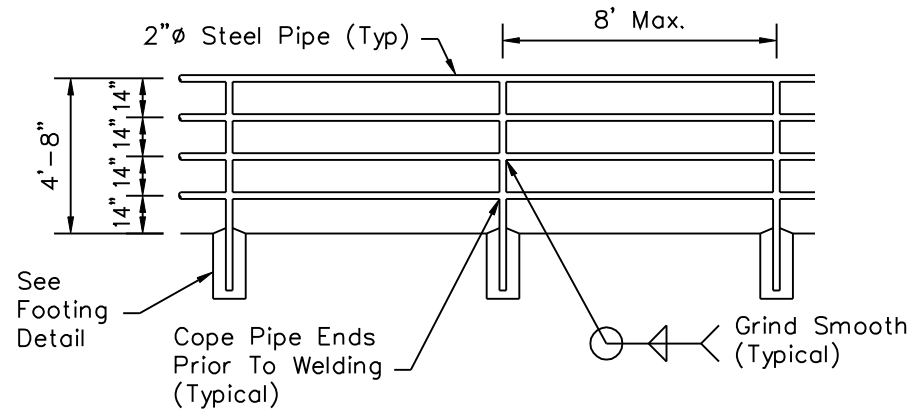

CONCRETE FOOTING DETAIL

STEEL RAIL

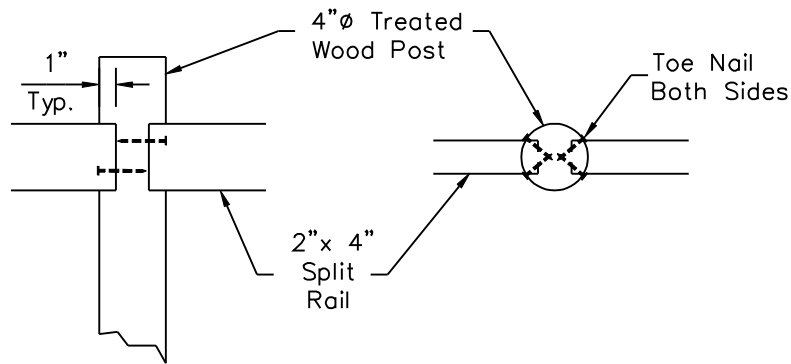

ELEVATION

PLAN

POST CONNECTION DETAIL

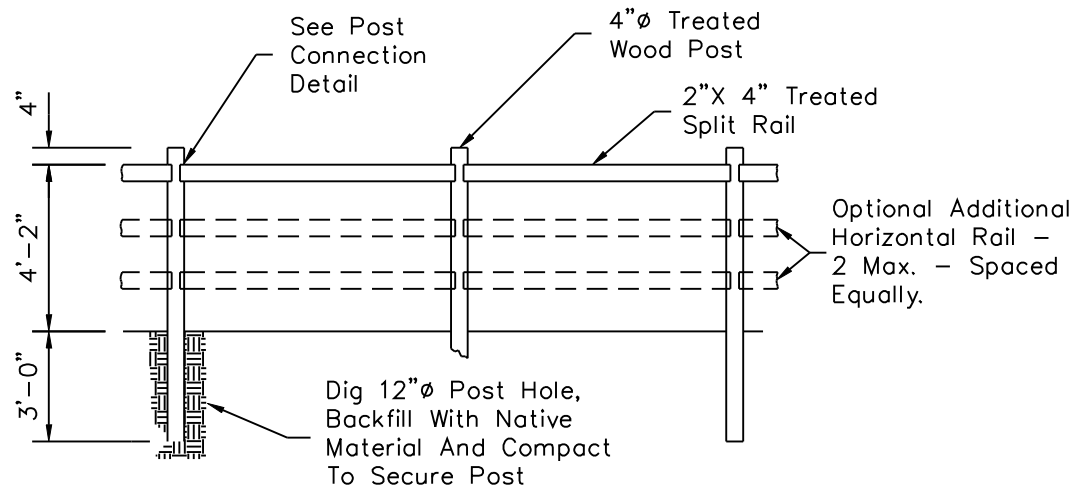

POST AND RAIL

DETAIL NO.
2682

**City of Scottsdale
Standard Details**

APPROVED BY:
**Scottsdale Standards &
Specifications Committee**

TRAIL SAFETY BARRIERS

DETAIL NO.
2682

REVISED 3/1/12

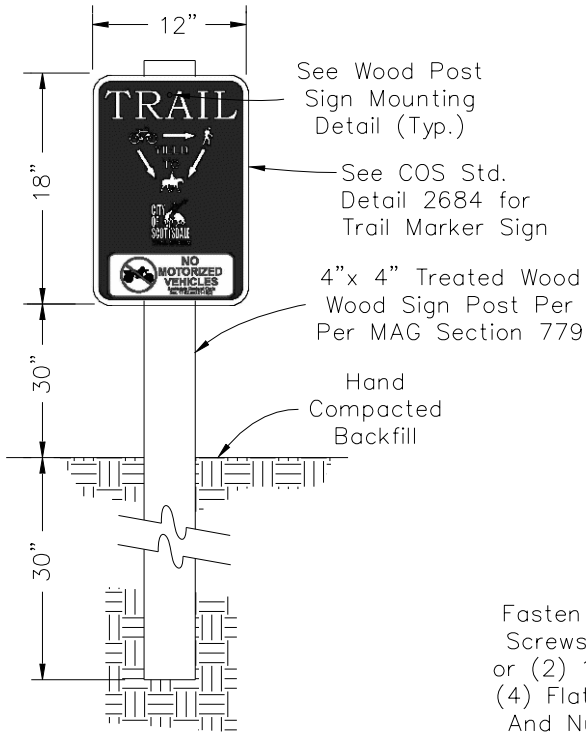

TRAIL MARKER

NOTES:

1. Signs shall conform to C.O.S. Supplemental Specifications, Section 402.3.
2. Signs to be mounted on square perforated tubing per C.O.S. Std Det 2131 within C.O.S. Right-of-Way. Treated wood post may be used for trail markers located outside C.O.S. Right-of Way.
3. Legends shall be reflectorized white vinyl sheeting on a green or brown vinyl background unless otherwise approved by the City of Scottsdale.
4. For signs located within Scenic Corridors, all sign backs shall be finished with a non-reflective dark color such as "Western Reserve 8716N Frazee" or similar, unless signs will be installed back to back on the same post.

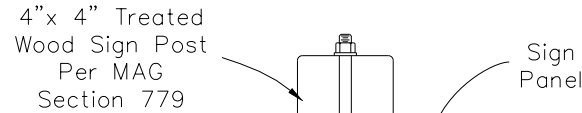

Fasten With (2) 1/2"x 2" Log Screws With (2) Flat Washers or (2) 1/2"x 4 1/2" Bolts With (4) Flat Washers. Burr Threads And Nuts With Center Punch.

WOOD POST SIGN MOUNTING DETAIL

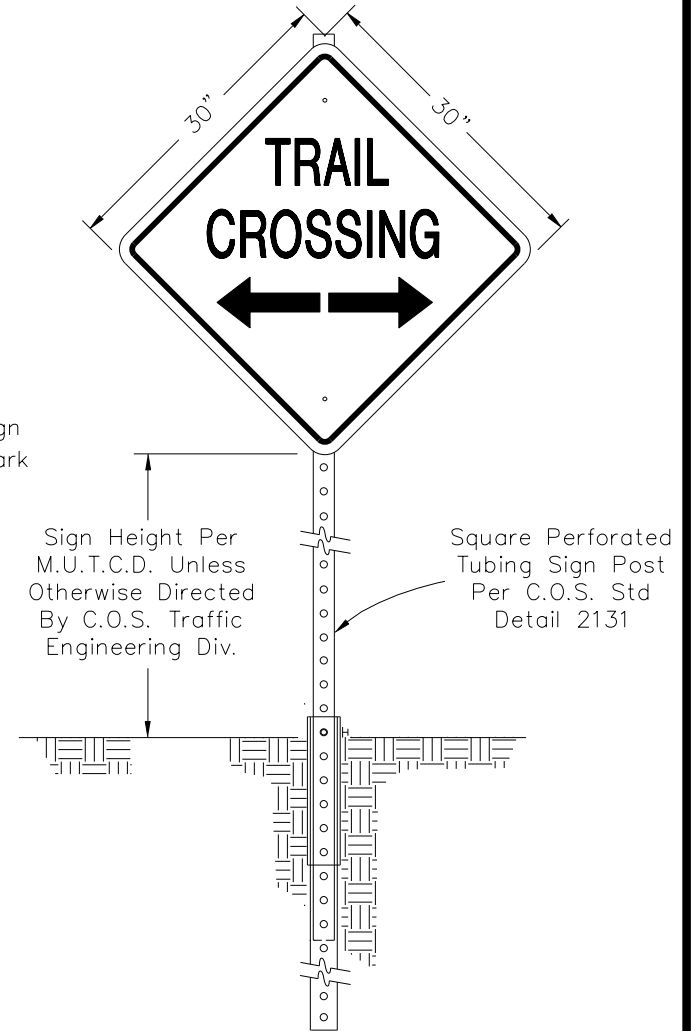

TRAIL CROSSING SIGN

DETAIL NO.
2683

City of Scottsdale
Standard Details

APPROVED BY:
Scottsdale Standards & Specifications Committee

TRAIL SIGNS

DETAIL NO.
2683

NEW 3/31/10

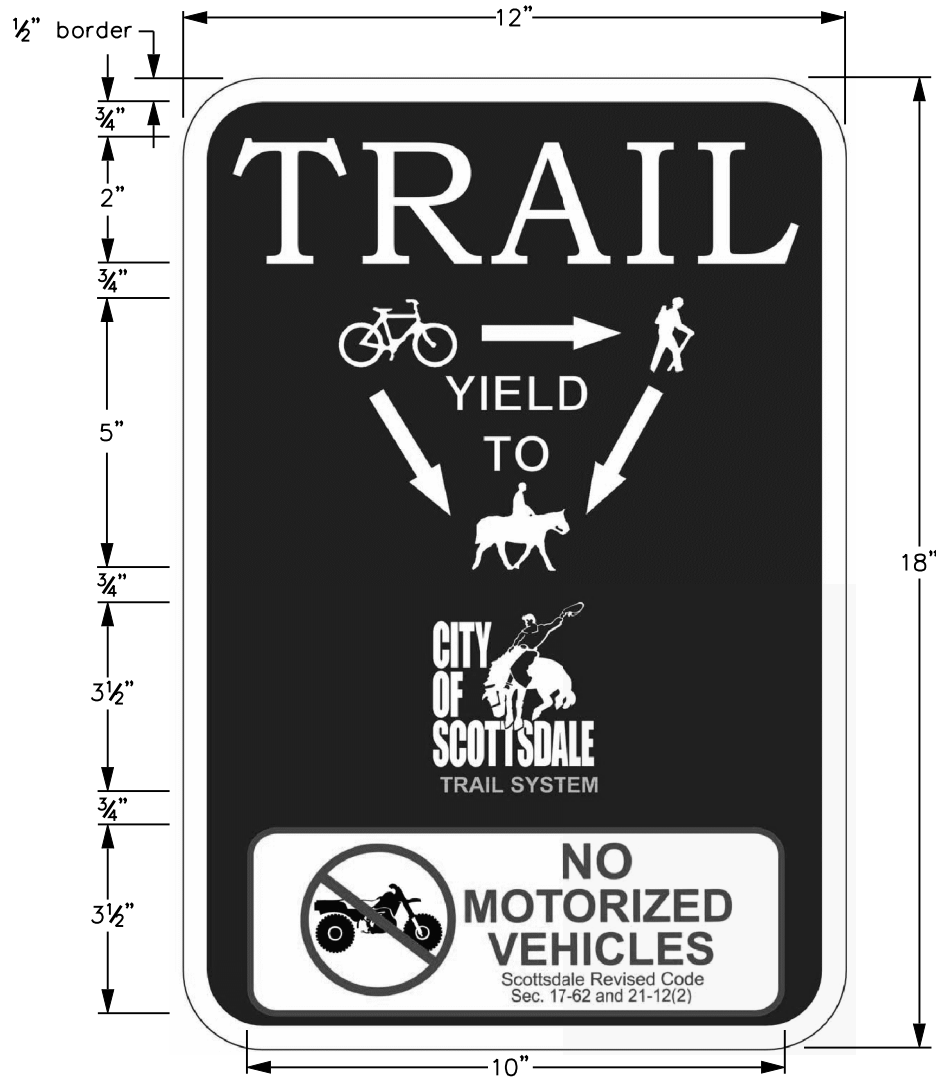

NOTES:

1. Signs shall conform to COS Spec. Sect. 402.3.
2. The sign substrate shall be treated aluminum with a thickness of 0.080".
3. The sign face shall have ASTM Type IV reflectorized sheeting with a brown screen printed or translucent acrylic EC overlay film reflective legend. Brown color shall be Pantone PMS 483 or closest equivalent. "NO MOTORIZED VEHICLES" portion shall be red text on white background except motor vehicle image shall be black.
4. Electronic version of sign graphics available upon request.
5. See COS Std. Detail 2683 for post and mounting details.

DETAIL NO.
2684

City of Scottsdale
Standard Details

APPROVED BY:
Scottsdale Standards & Specifications Committee

TRAIL MARKER SIGN

DETAIL NO.
2684