



SINGLE FAMILY DWELLING ELECTRICAL SERVICES RATED 225 TO 600 AMPS

A. PURPOSE

1. The following information includes the basic permit application requirements for a 120/240 volt single phase Electrical Service rated greater than 200 amperes, but not over 600 amperes, installed on a single family residential lot.
2. **CAUTION:** This handout and the National Electrical Code are not intended as design specifications nor instruction manuals for untrained persons. NEC 90-1(c). The National Electrical Code requires Qualified Persons to design electrical installations.

B. SCOPE

1. In general, the electrical equipment and wiring under the ownership or responsibility of the serving electrical utility is not regulated by the NEC. The applicable serving utility must be contacted for any additional requirements.
2. Unless otherwise noted, Code references shall be from the 1999 National Electrical Code (**NFPA 70 - NEC**) as amended by the current city adopted ordinance.
3. This should not be considered as a complete list of code requirements. Electrical Inspections must be performed and "Approved" before the work is considered completed by the City of Scottsdale.

C. DEFINITIONS (NEC Article 100)

1. Qualified Person – One familiar with the construction and operation of the equipment and the hazards involved, i.e. Licensed Electrical Engineer or Licensed Electrical Contractor.
2. Service (Electrical) – The conductors and equipment for delivering electric energy from the serving utility to the wiring system of the premises served.
3. Service Point – The point of connection between the facilities of the serving utility and the premises wiring.
4. Service Equipment – Also referred to as the Service Entrance Section or "SES". The necessary equipment usually consisting of circuit breakers or switches and fuses connected to the load end of service conductors to a building or other structure, or an otherwise designated area, and intended to constitute the main control and cutoff supply.
5. Subservice – The necessary equipment connected to the load side of service Equipment
6. Sub-Panel or Panel – A trade term for Subservice Panelboards or Load Centers.
7. Premises Wiring – All on-site wiring from the service point to the end utilization outlet.
8. Feeders – All circuit conductors between the Service Equipment and the final overcurrent device (circuit breaker).

D. LOCATION

1. Electrical Utility: While in the planning stage and before performing any work, contact the serving Electrical Utility regarding the location of the Service Point, installation requirements, equipment type and required clearances.

2. Clearances in front of the SES and Sub-Panels NEC 110-26:
 - (a) A minimum three (3) foot deep level space in front of the equipment. NEC 110-26(a)(1).
 - (b) Minimum 2'-6" (30") wide space or width of equipment, whichever is greater. NEC 110-26(a)(2).
 - (c) Equipment doors must be able to fully open 90 degrees. NEC 110-26(a)(2).
 - (d) Minimum 6'-6" high or top of the equipment, whichever is higher. NEC 110-26(a)(3), 110-26(e).
 - (e) The access and work space shall not be used for storage. NEC 110-26(b).
3. Outdoor/Water/Moisture – Service Equipment and Sub-Panels shall not be located where subject to water or moisture on a regular basis or in large quantities, i.e. where exposed to lawn sprinklers or below a roof scupper. NEC 110-26(f).
4. Vehicular traffic – Service Equipment and Sub-Panels shall not be located where subject to damage by vehicular traffic. NEC 110-26(f).
5. Clothes Closets – Service Equipment and Sub-Panels shall not be located in clothes closets. NEC 240-24(d).
6. Bathrooms – Service Equipment and Sub-Panels shall not be located in bathrooms. NEC 240-24(e).
7. Separate Buildings – Refer to NEC 225 Part B, 250-32, 250-50, 250-104 for required disconnecting means, grounding, and bonding.

E. PERMIT AND PLAN REQUIREMENTS

1. Site (Plot)Plan: Provide a simple site plan (minimum scale 1:40) indicating the location of existing building(s), structures, fences, pools, spas, etc, and the location or area where the Service and Panelboards are to be installed. Refer to the example attached.
2. Single Line (Feeder) Diagram NEC 215-5. – Example diagrams are attached for your information in preparing a Single Line Diagram. If any of these diagrams do not meet your needs then plans and calculations prepared by a Qualified licensed electrical contractor or licensed Electrical Engineer must be designed and submitted for review and approval.
3. Load Calculations NEC 220 – Provide Electrical Load Calculations for the Electrical Service (SES) and each sub-service panel to be installed. The Standard or Optional method may be used. An example of the Optional method is attached. Examples of both methods are located in Appendix D of the NEC.

F. INSPECTION REQUIREMENTS

The Inspection Card lists in detail the required inspections. The following inspections are for your information and may vary depending upon the installation.

1. Rough Electrical
2. Final Electric
3. Temporary Electric in Permanent Position is an option that can also be used. An Application and refundable deposit are required.
4. For service shut downs, please call Inspection Services to arrange an inspection.

PHONE NUMBERS

One Stop Shop (Electrical Permit)	408-312-2500
Electrical Plan review	480-312-7080
Inspection Services	480-312-5750
Automated Inspection Request Line	480-312-5796
Arizona Public Service	602-371-7171
Salt River Public	602-236-8888

RESIDENTIAL LOAD CALCULATIONS (NEC 220-30) OPTIONAL METHOD

SES / PANEL _____

A)	1)	_____ SF X 3 VA/SF		= _____ VA
	2)	_____ SMALL APPLIANCE CIRCUITS(MIN. 2) @	1500 VA	= _____ VA
	3)	_____ LAUNDRY CIRCUIT @	1500 VA	= _____ VA
	4)	_____ DISHWASHER @	750 VA	= _____ VA
	5)	_____ RANGE @ 12000VA	12000 VA	= _____ VA
	6)	_____ WATER HEATER @	5000 VA	= _____ VA
	7)	_____ DRYER @	5000 VA	= _____ VA
	8)	_____ MICROWAVE@	1500 VA	= _____ VA
	9)	_____ FORCED AIR UNIT	1500 VA	= _____ VA
	10)	_____	VA	= _____ VA
	11)	_____	VA	= _____ VA
	12)	_____	VA	= _____ VA
	13)	_____	VA	= _____ VA
	14)	_____	VA	= _____ VA
	15)	_____	VA	= _____ VA
		SUBTOTAL		= _____ VA
	B)	FIRST 10,000VA @ 100%		= _____ VA
		REMAINING _____ VA @ 40%		= _____ VA
	C)	A/C @ 100%		= _____ VA
	D)	POOL PANEL/EQUIPMENT		= _____ VA
	E)	TOTAL VOLT AMPS		= _____ VA
	F)	TOTAL AMPS (TOTAL VA / 240 VOLTS)		= _____ AMPS

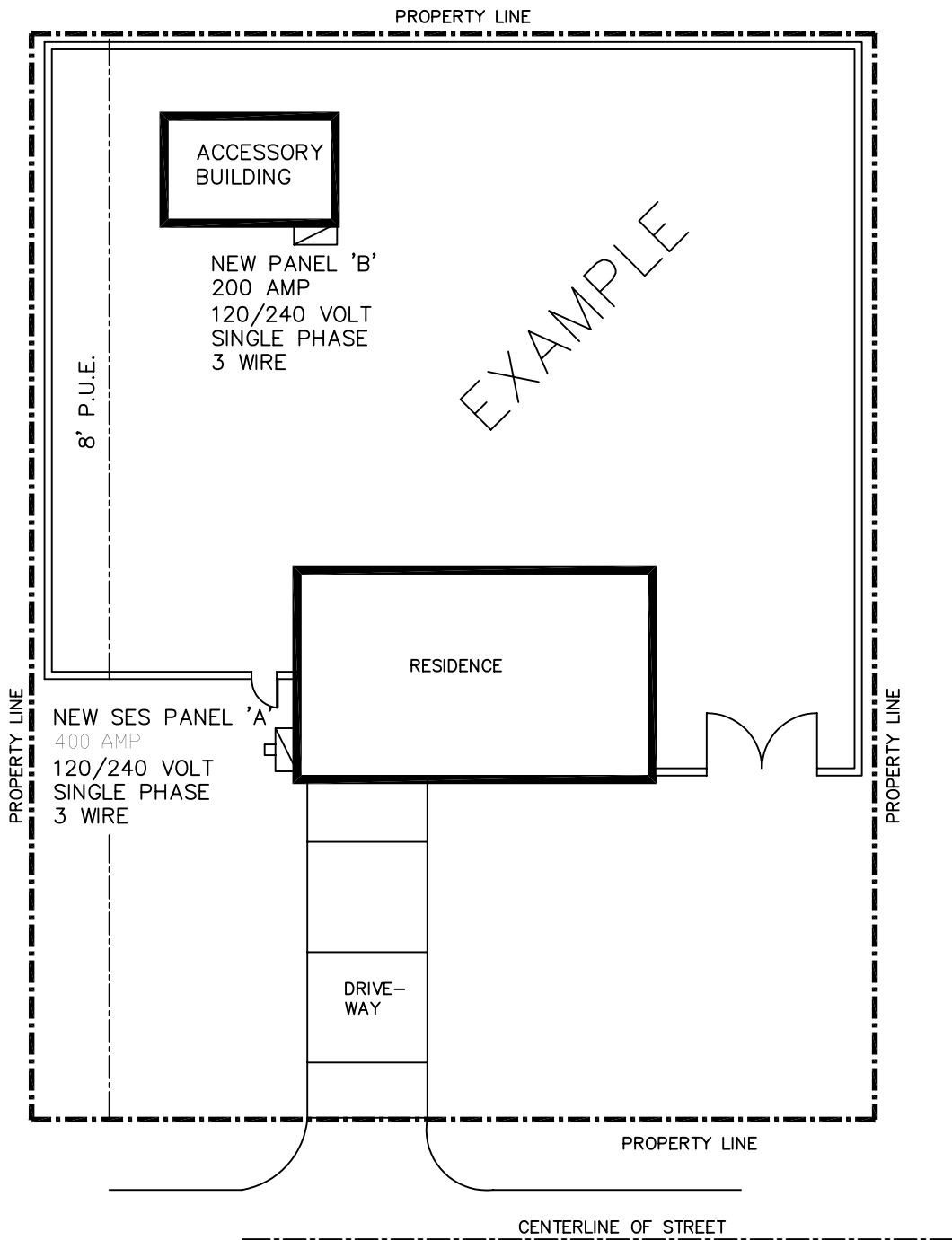

ELECTRICAL SITE PLAN



ADDRESS: _____

**EXAMPLE OF A 400 AMP
RESIDENTIAL SES ONE-LINE DIAGRAM
NOTE! SERIES RATED SYSTEM**

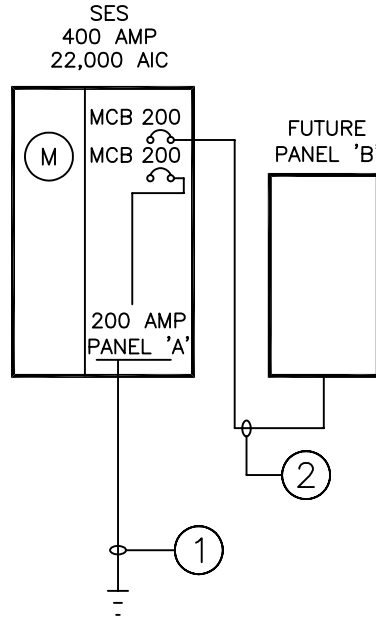

- ① #2 CU GAS BOND(WHEN AVAILABLE)
#1/0 CU WATER BOND
#4 CU UFER
- ② 2" C 3 #4/0 CU, 1 #6 CU
- ③ #4 CU GAS BOND
#4 CU WATER BOND
#4 CU UFER

**EXAMPLE OF A 400 AMP
RESIDENTIAL SES ONE-LINE DIAGRAM
NOTE! SERIES RATED SYSTEM**

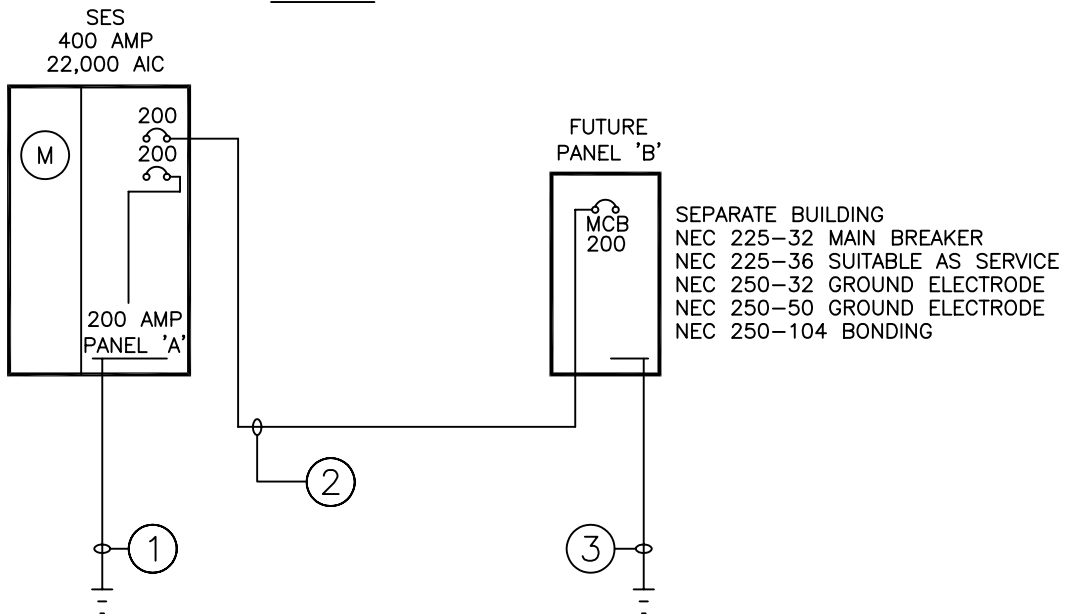

**EXAMPLE OF A 400 AMP
RESIDENTIAL SES ONE-LINE DIAGRAM
NOTE! SERIES RATED SYSTEM**

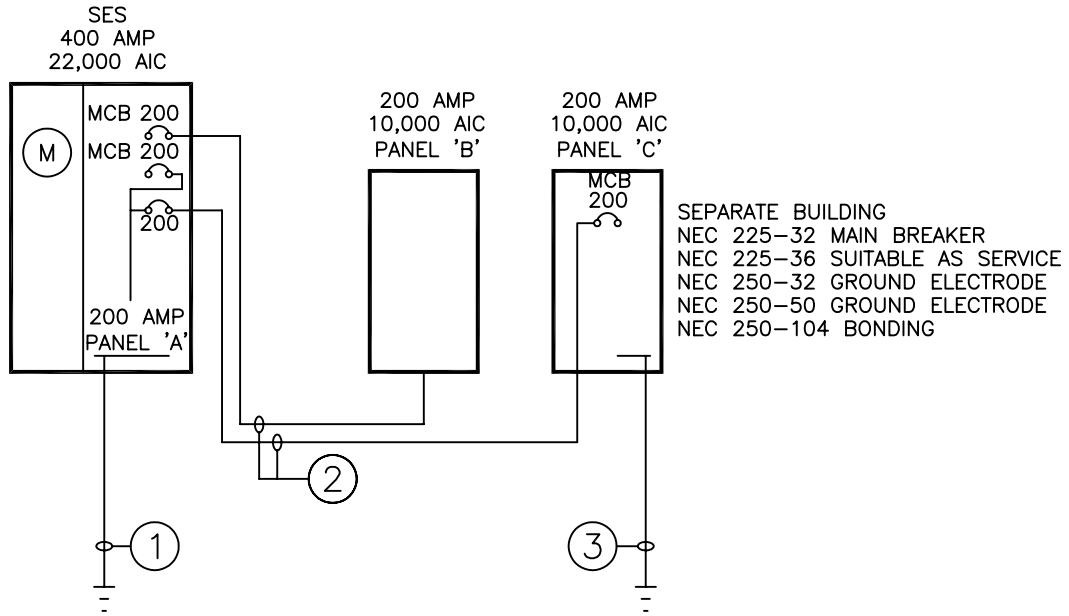

① #2 CU GAS BOND(WHEN AVAILABLE)
#1/0 CU WATER BOND
#4 CU UFER

② 2" C 3 #4/0 CU, 1 #6 CU

③ #4 CU GAS BOND
#4 CU WATER BOND
#4 CU UFER

**EXAMPLE OF A 400 AMP
RESIDENTIAL SES ONE-LINE DIAGRAM
NOTE! SERIES RATED SYSTEM**

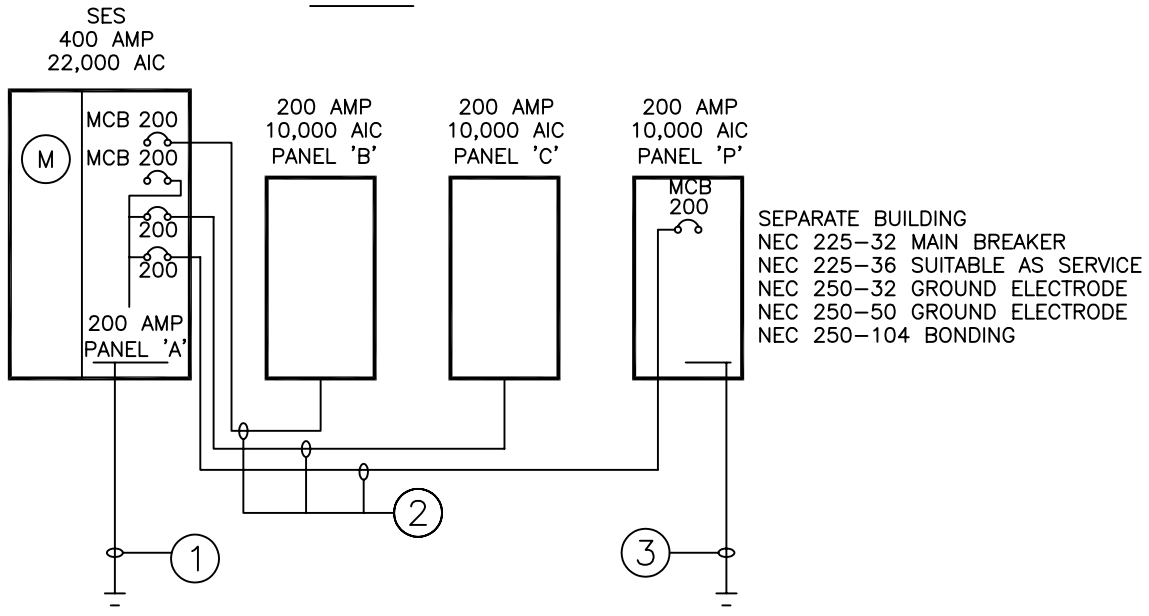

**EXAMPLE OF A 600 AMP
RESIDENTIAL SES ONE-LINE DIAGRAM
NOTE! SERIES RATED SYSTEM**

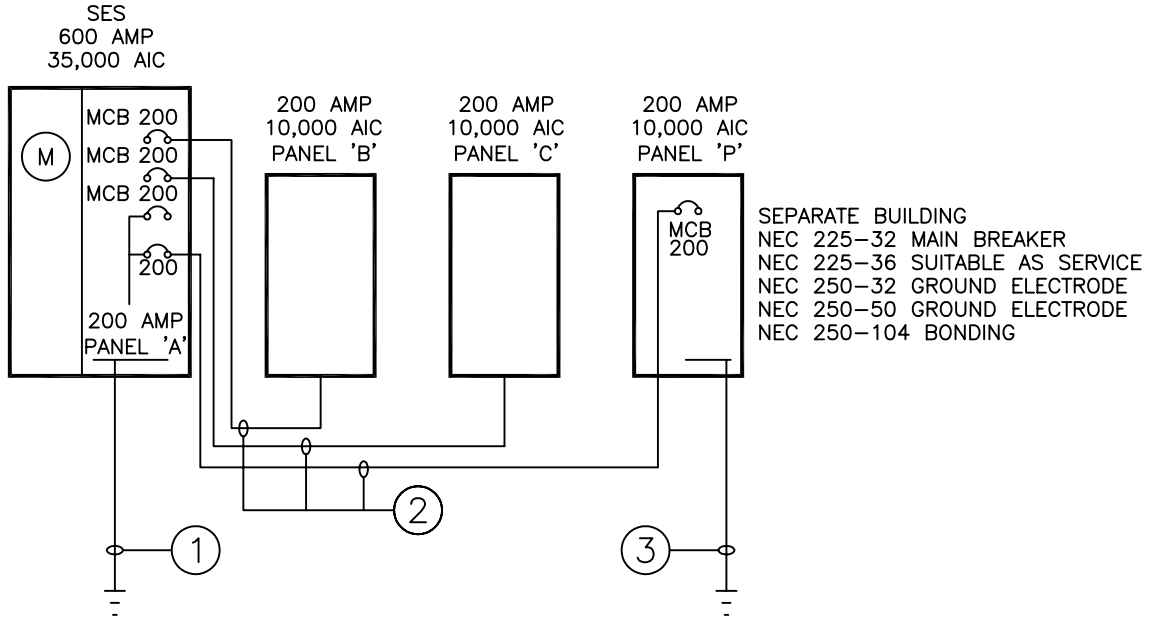

① #1 CU GAS BOND(WHEN AVAILABLE)
#2/0 CU WATER BOND
#4 CU UFER

② 2" C 3 #4/0 CU, 1 #6 CU

③ #4 CU GAS BOND
#4 CU WATER BOND
#4 CU UFER

**EXAMPLE OF A 600 AMP
RESIDENTIAL SES ONE-LINE DIAGRAM
NOTE! SERIES RATED SYSTEM**

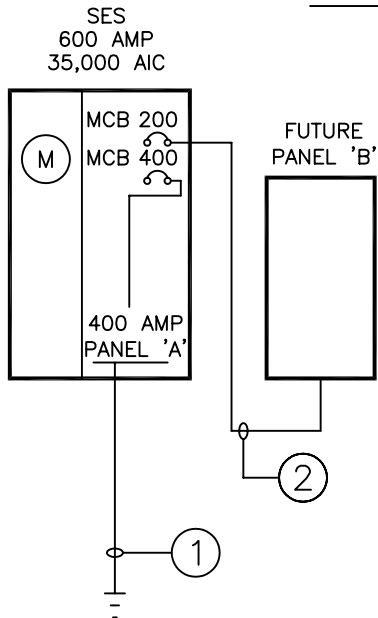

**EXAMPLE OF A 600 AMP
RESIDENTIAL SES ONE-LINE DIAGRAM
NOTE! SERIES RATED SYSTEM**

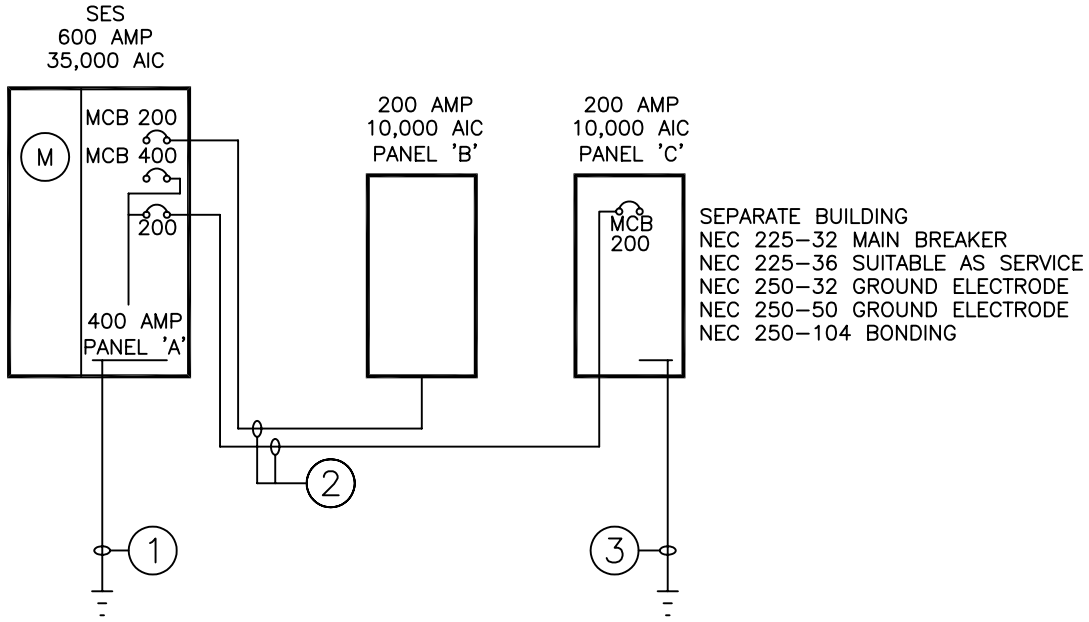

① #1 CU GAS BOND(WHEN AVAILABLE)
#2/0 CU WATER BOND
#4 CU UFER

② 2" C 3 #4/0 CU, 1 #6 CU

③ #4 CU GAS BOND
#4 CU WATER BOND
#4 CU UFER

**EXAMPLE OF A 600 AMP
RESIDENTIAL SES ONE-LINE DIAGRAM
NOTE! SERIES RATED SYSTEM**

